

RS08x06 Series 8A TRIACS

DESCRIPTION:

High current density due to double mesa technology, SIPOS and Glass Passivation.

RS08x06 -D -E -F -G series triacs is suitable for general purpose AC switching.

They can be used as an ON/OFF function in applications such as static relays, heating regulation, induction motor starting circuits...or for phase control operation, light dimmers, motor speed controllers.

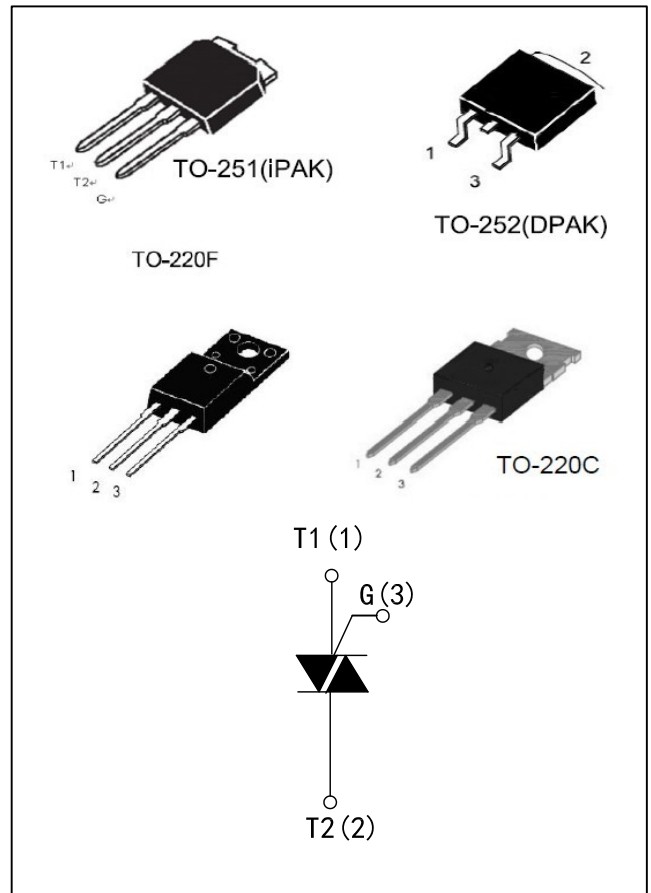

MAIN FEATURES

Symbol	Value	Unit
$I_{T(RMS)}$	8	A
V_{DRM}/V_{RRM}	600 to 800	V
V_{TM}	≤ 1.65	V

ABSOLUTE MAXIMUM RATINGS

Parameter	Symbol	Value	Unit
Storage junction temperature range	Tstg	-40 to +150	°C
Operating junction temperature range	Tj	-40 to +125	°C
Repetitive Peak Off-state Voltage Repetitive Peak Reverse Voltage	V_{DRM} V_{RRM}	600 to 800 600 to 800	V
Non repetitive Surge Peak Off-state Voltage Non repetitive Peak Reverse Voltage	V_{DSM} V_{RSM}	700 to 900 700 to 900	V
RMS on-state current (full sine wave)	$I_{T(RMS)}$	8	A
Non repetitive surge peak on-state current (full cycle, Tj=25°C)	f = 50 Hz t=20ms	65	A
	f = 60 Hz t=16.7ms	71	A
I ² t Value for fusing tp=10ms	I ² t	21	A ² s
Critical rate of rise of on-state current IG=2×IGT, tr≤100 ns, f=120Hz, Tj=125°C	di /dt	50	A/us
Peak gate current tp=20us, Tj=125°C	IGM	2	A
Average gate power dissipation Tj=125°C	PG(AV)	0.5	W

ELECTRICAL CHARACTERISTICS (T_j=25°C unless otherwise specified)

Symbol	Test Condition	Quadrant		RS08x06				Unit
				D	E	F	G	
I _{GT}	V _D =12V R _L =30Ω	I - II - III IV	MAX.	5 10	10 25	25 70	50 100	mA
V _{GT}		ALL	MAX.	1.5				V
V _{GD}	V _D =V _{DRM} R _L =3.3KΩ T _j =125°C	ALL	MIN.	0.2				V
I _L	I _G =1.2I _{GT}	I - III	MAX.	15	15	30	45	mA
		II - IV		20	20	45	60	
I _H	I _T =100mA		MAX.	10	15	20	40	mA
dV/dt	V _D =67%V _{DRM} gate open T _j =125°C		MIN.	5	50	50	200	V/μs
(di/dt) _c	(dV/dt) c=0.1V/μs T _j =125°C		MIN.	---	---	---	---	A/ms
	(dV/dt) c=10V/μs T _j =125°C			---	---	---	---	
	Without snubber T _j =125°C			---	---	---	---	

STATIC CHARACTERISTICS

Symbol	Test Conditions		Value (MAX)	Unit
V _{TM}	I _{TM} =10A, t _p =380μs	T _j =25°C	1.65	V
I _{DRM}	V _D =V _{DRM}	T _j =25°C	5	μA
I _{RRM}	V _R =V _{RRM}	T _j =125°C	1	mA

THERMAL RESISTANCES

Symbol	Parameter		Value	Unit
R _{th(j-c)}	Junction to case (AC)	full cycle	2.0	°C/W
		half cycle	2.4	

ORDERING INFORMATION

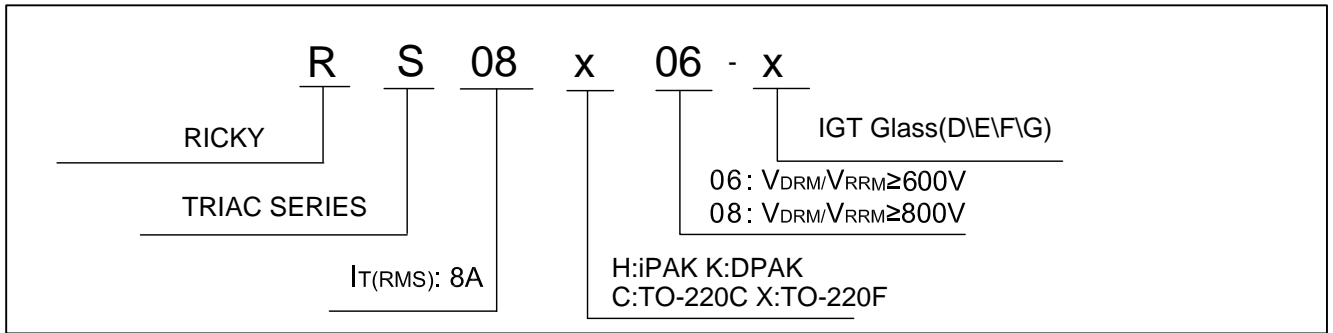

PACKAGE MECHANICAL DATA

TO-220C

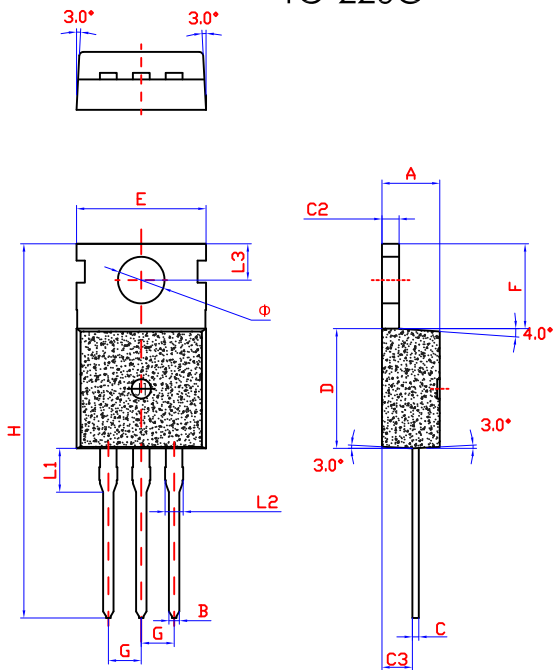

Ref.	Dimensions					
	Millimeters			Inches		
	Min.	Typ.	Max.	Min.	Typ.	Max.
A	4.4		4.6	0.173		1.181
B	0.7		0.9	0.027		0.035
C	0.45		0.6	0.018		0.024
C2	1.23		1.32	0.048		0.052
C3	2.2		2.6	0.086		0.102
D	8.9		9.9	0.350		0.390
E	9.9		10.3	0.390		0.406
F	6.3		6.9	0.248		0.272
G		2.54			0.1	
H	28.0		29.8	11.0		11.7
L1		3.2			0.126	
L2	1.14		1.7	0.045		0.067
L3	2.65		2.95	0.104		0.116
Φ		3.6			0.142	

TO-220F

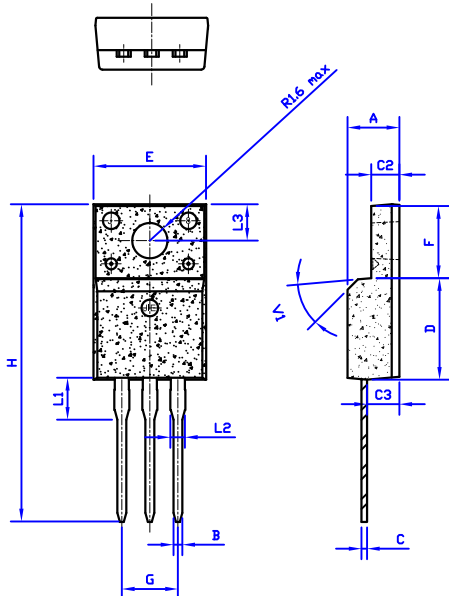

Ref.	Dimensions					
	Millimeters			Inches		
	Min.	Typ.	Max.	Min.	Typ.	Max.
A	4.3		4.7	0.169		0.185
B	0.74	0.8	0.83	0.029	0.031	0.033
C	0.5		0.75	0.020		0.030
C2	2.4		2.7	0.094		0.106
C3	2.5		2.9	0.098		0.114
D	8.6		9.2	0.338		0.362
E	9.7		10.3	0.382		0.406
F	6.3		6.5	0.248		0.256
G	5.0		5.2	0.197		0.205
H	28.0		29.8	11.0		11.7
L1		3.63			0.143	
L2	1.14		1.7	0.044		0.067
L3		3.2			0.126	
V1		40°			40°	

PACKAGE MECHANICAL DATA

TO-252(DPAK)

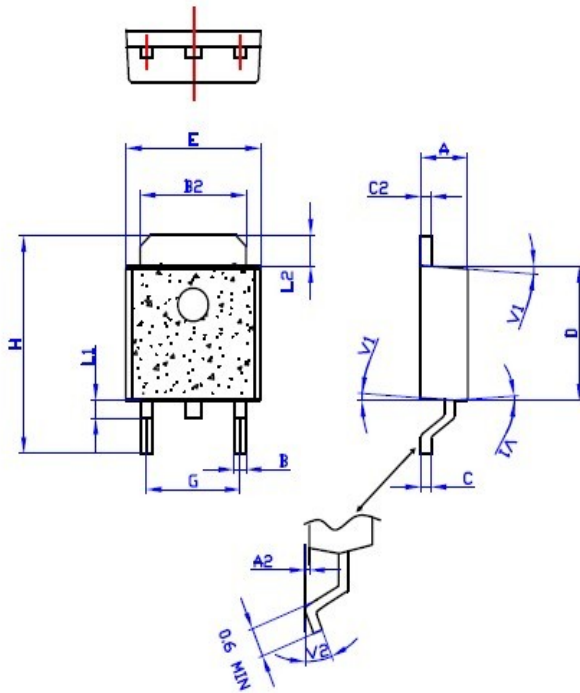

Ref.	Dimensions					
	Millimeters			Inches		
	Min.	Typ.	Max.	Min.	Typ.	Max.
A	2.2		2.4	0.086		0.095
A2	0.03		0.23	0.001		0.009
B	0.55		0.65	0.021		0.026
B2	5.1		5.4	0.200		0.212
C	0.45		0.62	0.017		0.024
C2	0.48		0.62	0.019		0.024
D	6		6.2	0.236		0.244
E	6.4		6.7	0.252		0.264
G	4.40		4.70	0.173		0.185
H	9.35		10.1	0.368		0.397
L1		0.8			0.031	
L2	1.37		1.5	0.054		0.059
V1		4°			4°	
V2	0°		8°	0°		8°

TO-251(IPAK)

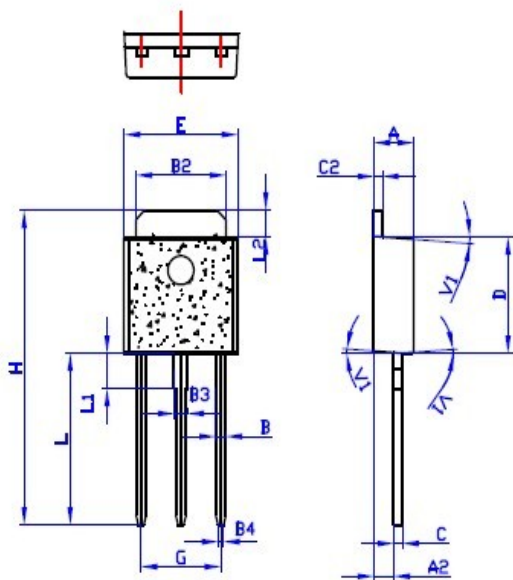

Ref.	Dimensions					
	Millimeters			Inches		
	Min.	Typ.	Max.	Min.	Typ.	Max.
A	2.2		2.4	0.086		0.095
A2	0.9		1.1	0.035		0.043
B	0.55		0.65	0.021		0.026
B2	5.1		5.4	0.200		0.212
B3	0.76		0.85	0.030		0.033
B4		0.32			0.013	
C	0.45		0.62	0.017		0.024
C2	0.48		0.62	0.019		0.024
D	6		6.2	0.236		0.244
E	6.4		6.7	0.252		0.264
G	4.4		4.7	0.173		0.185
H	16.0		16.7	0.630		0.658
L	8.9		9.4	0.350		0.370
L1	1.8		1.9	0.071		0.075
L2	1.37		1.5	0.054		0.059
V1		4°			4°	

FIG.1: Maximum power dissipation versus RMS on-state current(full cycle)

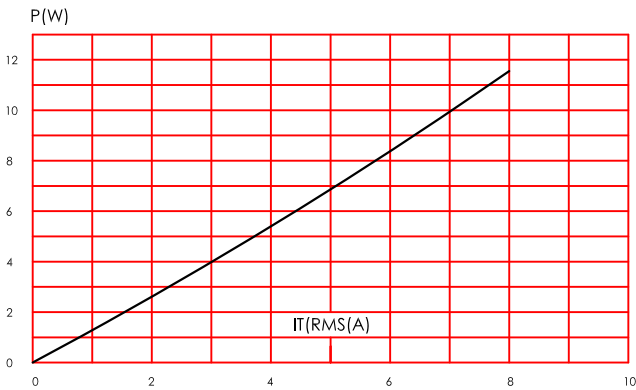

FIG.2: RMS on-state current versus case temperature(full cycle)

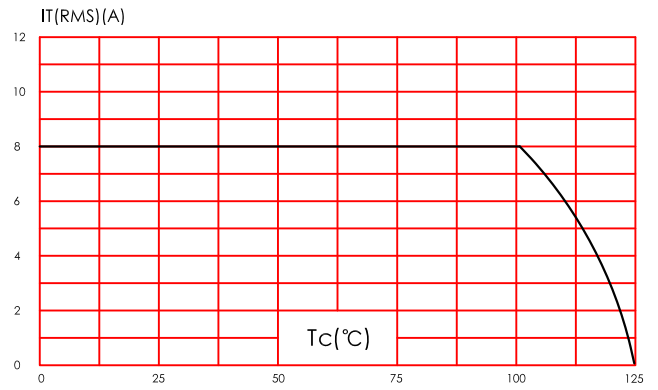

FIG.3: On-state characteristics (maximum values)

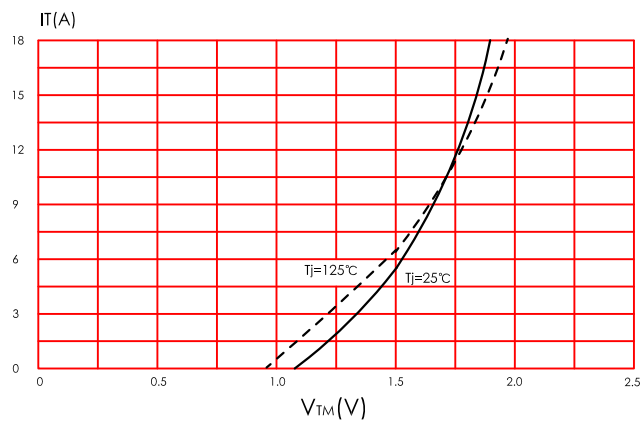

FIG.4: Surge peak on-state current versus number of cycles.

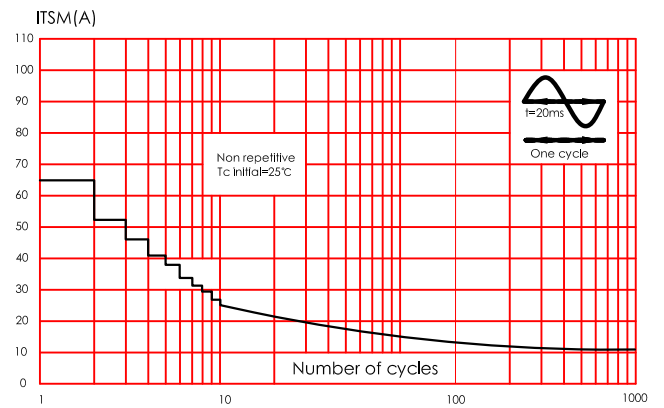

FIG.5: Non-repetitive surge peak on-state current for a sinusoidal pulse with width $t_p < 10ms$

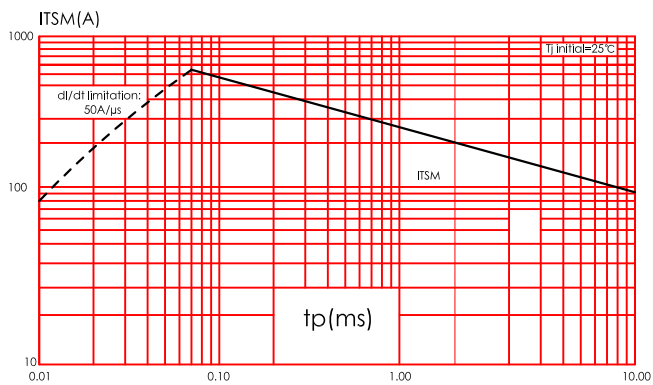
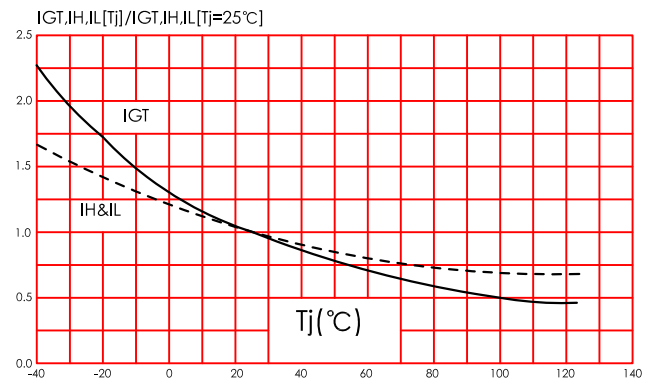

FIG.6: Relative variation of gate trigger current, holding current and latching current versus junction temperature (typical values).



X-ON Electronics

Largest Supplier of Electrical and Electronic Components

Click to view similar products for [Triacs](#) category:

Click to view products by [Haoruijia](#) manufacturer:

Other Similar products are found below :

[BT137-600-0Q](#) [2N6075A](#) [NTE5688](#) [D31410](#) [ACS102-5T1](#) [ACS102-5TA](#) [MAC97A4G](#) [Z0107MAG](#) [Z0107MARL1G](#) [Z0109MARLRPG](#)
[BTA316-800ET,127](#) [BTA316-800CTQ](#) [ACTT8X-800CTNQ](#) [MCR22-6G](#) [BTA16-800B\(MS\)](#) [TYN1025RG-JSM](#) [BT138-600D](#) [BTA26-800BRG](#) [BT138-600E](#) [BTA24-600CWRG](#) [BTA16-800CWRG](#) [BT138-600E](#) [BTA08-800CW](#) [BTB24-800CW](#) [BTA16-800CW](#) [BTA16-600CW](#) [BT169](#) [MCR100-6U](#) [FT10050-12P](#) [BT151S-600R](#) [BT136-800E](#) [BT136S](#) [PCR606J](#) [CT404D-800S](#) [JST24A-800CW](#) [JST60IS-1600BW](#) [TYN810RG-JSM](#) [BT139B-600E-JSM](#) [TYN812RG-JSM](#) [BT152-800R](#) [BTB16-800BRG-JSM](#) [BTA20-800CRG TO-220](#) [BTA16-800BRG](#) [BTW69-1200RG](#) [TYN825RG-JSM](#) [BTA12-600CRG](#) [BT136-600E](#) [BTA12-600BRG](#) [BT139-600E](#) [BTA24-800CRG TO-220](#)