



DIN Signal har-bus 64 female connector

General information

Design	IEC 61076-4-113	type: har-bus 64 female
No. of contacts	max. 160	
Contact spacing	2,54mm	
Test voltage	1000V	
Contact resistance	max. 20mOhm for rows a, b, c	max. 30mOhm for rows d, z
Insulation resistance	min. 10 ¹⁰ Ohm	
Working current	1A at 70°C (see derating diagram)	
Temperature range	-40°C ... +105°C (due to limitations of PCB material)	
Termination technology	press-in	

Clearance & creepage		minimum distance		
		rows a, b, c	rows d, z	
between 2 rows	clearance	1,2mm	1,2mm	
	creepage	1,2mm	1,2mm	
	between 2 contacts in a row	clearance	1,2mm	1,0mm
		creepage	1,2mm	1,0mm

Insertion and withdrawal force	max. 160N
PCB thickness	min. 1,6mm
Mating cycles	acc. to performance level, see table below
UL file	E102079
RoHS - compliant	Yes
Leadfree	Yes

Insulator material

Material	LCP (Liquid Cristal Polymer)
Colour	nature
UL classification	UL 94-V0
Material group acc. to IEC 60664-1	IIIa (175 ≤ CTI < 400)

Contact material

Contact material	Copper alloy
Plating termination zone	Ni
Plating contact zone I	acc. to performance level, see table below
Plating contact zone II (termination side)	acc. to performance level, see table below

performance level	mating cycles		plating contact zone I plating contact zone II	
	acc. to IEC 61076-4-113	complementary acc. to IEC 61076-4-113	row d,z	row a,b,c
1	500		Au over Ni	Au over PdNi over Ni
2	250		Au over Ni	Au over PdNi over Ni
3		50	Au over Ni	Au over PdNi over Ni
Au30		500	min. 0,76µm (30pinch) Au over Ni	
Au50		500	min. 1,27µm (50pinch) Au over Ni	

Standard plating options highlighted in bold, other plating options are available on request.

Recommended configuration of plated through holes for press-in termination

In addition to the hot-air-level (HAL), other PCB surfaces are getting more important. Due to their different properties - such as mechanical strength and coefficient of friction - we recommend the following configuration of PCB through holes.

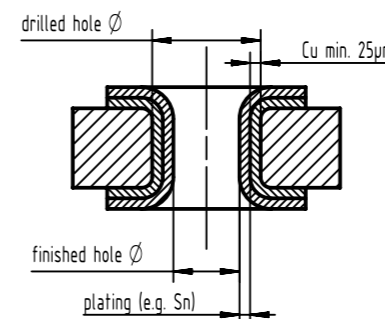

Tin plated PCB (HAL) acc. to EN 60352-5	Drilled hole Ø	1,15±0,025 mm
	Sn	max. 15 µm
	plated hole Ø	0,94 - 1,09 mm
Chemical tin plated PCB	Drilled hole Ø	1,15±0,025 mm
	Sn	min. 0,8µm
	plated hole Ø	1,00 - 1,10 mm
Gold /Nickel plated PCB	Drilled hole Ø	1,15±0,025 mm
	Ni	3 - 7 µm
	Au	0,05 - 0,12 µm
	plated hole Ø	1,00 - 1,10 mm
Silver plated PCB	Drilled hole Ø	1,15±0,025 mm
	Ag	0,1 - 0,3 µm
	plated hole Ø	1,00 - 1,10 mm
Copper plated PCB (OSP)	Drilled hole Ø	1,15±0,025 mm
	plated hole Ø	1,00 - 1,10 mm

Assembly instructions

It is highly recommended to use HARTING press-in tools to ensure a reliable press-in process. Please refer to the catalogue for tools, machines and further information about the press-in process.



Derating diagram acc. to IEC 60512-5 (Current carrying capacity)

The current carrying capacity is limited by maximum temperature of materials for inserts and contacts including terminals.

The current capacity curve is valid for continuous, non interrupted current loaded contacts of connectors when simultaneous power on all contacts is given, without exceeding the maximum temperature. Control and test procedures according to DIN IEC 60512-5

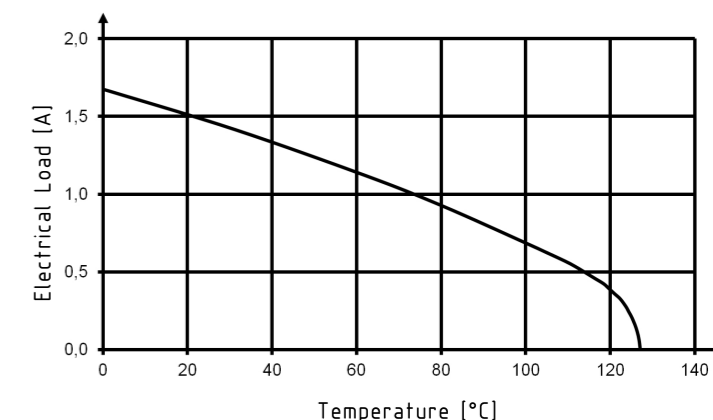
With selective loading higher currents can be transmitted. The requirements according to VITA 1.7 are fulfilled.



	All Dimensions in mm Original Size DIN A3	Scale 1:1	Free size tol.	Ref. Sub.
	All rights reserved Department EL PD	Created by STORCK	Inspected by LEHNERT	Standardisation 302077
	HARTING Electronics GmbH D-32339 Espelkamp	Title DIN Signal har-bus 64 female connector		Date 2020-11-27
		Type DS	Number 02022100101	State Final Release
				Doc-Key / ECM-Nr. 100556639/UGD/001/C 500000131790
				Rev. C Page 1/1

X-ON Electronics

Largest Supplier of Electrical and Electronic Components

Click to view similar products for [DIN 41612 Connectors](#) category:

Click to view products by [HARTING](#) manufacturer:

Other Similar products are found below :

[004.767](#) [608489050008049](#) [691327-1](#) [74670-0732](#) [74680-0340](#) [75880-0015](#) [76453-0014](#) [86093159ALF](#) [9732967801](#) [QLC260R](#)
[120X10019X](#) [120X10089X](#) [122A10249X](#) [122A10669X](#) [122A11089X](#) [122A13089X](#) [122A10089X](#) [122A10129X](#) [122A10349X](#)
[122A13359X](#) [1377391-4](#) [DIN-048CPC-SR1-MH](#) [1393583-2](#) [1393726-7](#) [140X10129X](#) [143-1913-000](#) [143-1908-000](#) [1484472-1](#) [2110070-1](#)
[2110070-2](#) [CBC20T00-008FDS5-0-1-002VR](#) [172699-5036](#) [2-1393557-4](#) [2-1437084-2](#) [CTJ720E01B-6141](#) [394506](#) [419-2080-402](#)
[V42254B2202C968](#) [419-2086-201](#) [419-2087-002](#) [448657-1](#) [448847-3](#) [5-1393755-9](#) [02990000004](#) [054302](#) [043556](#) [09062483201750](#)
[0850033067](#) [09031646555](#) [09061486901840](#)