



DIN Signal female connector - CTI > 400



General information

Design	IEC 60603-2	types: B, C, M female
No. of contacts	max. 96	
Contact spacing	2,54 mm	
Test voltage	1000V	
Contact resistance	max. 15mOhm	
Insulation resistance	min. 10 ⁹ Ohm	
Working current	2A at 20°C (see derating diagram)	40 A for type M
Temperature range	-55°C ... +125°C	
	-40°C ... +105°C	(for press-in connectors)
Termination technology	press-in, solder pins	
Clearance & creepage distance	min. 1,2 mm each	
Insertion and withdrawal force	16-pole max. 15N	20-pole max. 20N
	48-pole max. 45N	64-pole max. 60N
		96-pole max. 90N
Mating cycles	acc. to performance level, see table below	
UL file	E102079	
RoHS - compliant	Yes	
Leadfree	Yes	
Hot plugging	No	

Insulator material

Material	PCT (thermoplastics, glass fiber reinforcement 30%)
Color	natural coloured, colour denations and speckles permitted
UL classification	UL 94-V0
Material group acc. IEC 60664-1	II (400 < CTI < 600)
NFF classification	I3, F3

Contact material

Contact material	Copper alloy
Plating termination zone	Sn over Ni for solder, Ni for press-in
Plating contact zone	acc. to performance level, see table below

performance level	mating cycles		plating contact zone
	acc. to IEC 60603-2	complementary acc. to IEC 60603-2	
1	500		<i>Au over PdNi over Ni</i>
2	400		<i>Au over PdNi over Ni</i>
3	50		<i>Au over PdNi over Ni</i>
NM30 (S4)		500	min. 0,76µm (30pinch) noble metal (alloy) over Ni
Au30		500	min. 0,76µm (30pinch) Au over Ni
Au50		500	min. 1,27µm (50pinch) Au over Ni
Au70		500	min. 1,60µm (70pinch) Au over Ni

Standard plating options highlighted in *italic*, other plating options are available on request.

Recommended configuration of plated through holes for press-in termination

In addition to the hot-air-level (HAL), other PCB surfaces are getting more important. Due to their different properties - such as mechanical strength and coefficient of friction - we recommend the following configuration of PCB through holes.

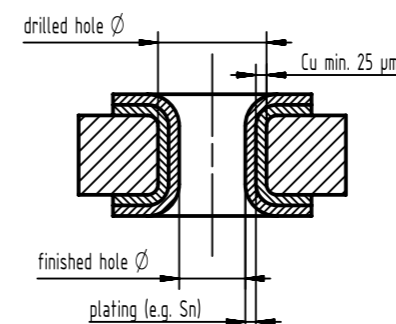

Tin plated PCB (HAL) acc. to EN 60352-5	Drilled hole Ø	1,15±0,025 mm
	Sn plated hole Ø	max. 15 µm
Chemical tin plated PCB	Drilled hole Ø	1,15±0,025 mm
	Sn plated hole Ø	min. 0,8 µm
Gold / Nickel plated PCB	Drilled hole Ø	1,15±0,025 mm
	Sn plated hole Ø	3 - 7 µm
	Au plated hole	0,05 - 0,12 µm
Silver plated PCB	Drilled hole Ø	1,15±0,025 mm
	Ag plated hole Ø	0,1 - 0,3 µm
Copper plated PCB (OSP)	Drilled hole Ø	1,15±0,025 mm
	plated hole Ø	1,00 - 1,10 mm

Assembly instructions

It is highly recommended to use HARTING press-in tools to ensure a reliable press-in process. Please refer to the catalogue for tool, machines and further information about the press-in process.

Soldering instructions

The connectors should be protected when being soldered in a dip, flow or film soldering baths. Otherwise, they might become contaminated as a result of soldering operations or deformed as a result of overheating.

(1) For prototypes and short runs protect the connectors with an industrial adhesive tape, e.g. Tesaband 4331 (www.tesa.de). Cover the underside of the connector moulding and the adjacent parts of the pcb as well as the open sides of the connector. This will prevent heat and gases of the soldering apparatus from damaging the connector. About 140 + 5 mm of the tape should suffice.

(2) For large series a jig is recommended. Its protective cover with a fast action mechanical locking device shields the connectors from gas and heat generated by the soldering apparatus. As an additional protection a foil can be used for covering the parts that should not be soldered.

Cross section of solder terminations

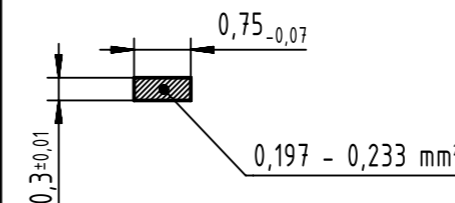

Derating diagram acc. to IEC 60512-5 (Current carrying capacity)

The current carrying capacity is limited by maximum temperature of materials for inserts and contacts including terminals.

The current capacity curve is valid for continuous, non interrupted current loaded contacts of connectors when simultaneous power on all contacts is given, without exceeding the maximum temperature.

Control and test procedures according to DIN IEC 60512-5

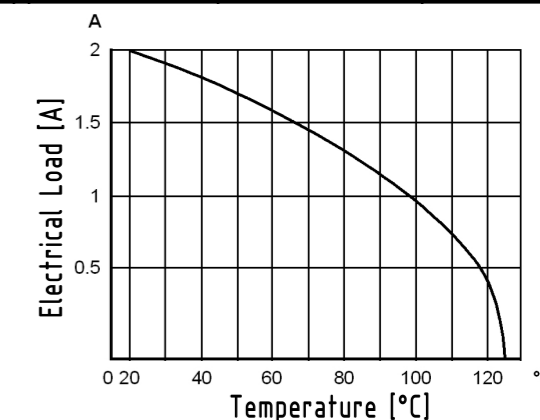

	All Dimensions in mm Original Size DIN A3	Scale 1:1	Free size tol.	Ref.
				Sub.
	All rights reserved Department EC PD - DE	Created by STORCK	Inspected by LEHNERT	Standardisation HOFFMANN
		Date 2018-06-19	State Final Release	
Title DIN Signale female connector - CTI > 400				Doc-Key / ECM-Nr. 100627410/UGD/000/C 500000136475
HARTING Electronics GmbH D-32339 Espelkamp		Type DS	Number 09032130203	Rev. C Page 1/1

X-ON Electronics

Largest Supplier of Electrical and Electronic Components

Click to view similar products for [DIN 41612 Connectors](#) category:

Click to view products by [HARTING](#) manufacturer:

Other Similar products are found below :

[004.767](#) [608489050008049](#) [691327-1](#) [74670-0732](#) [74680-0340](#) [75880-0015](#) [76453-0014](#) [86093159ALF](#) [9732967801](#) [QLC260R](#)
[120X10019X](#) [120X10089X](#) [122A10249X](#) [122A10669X](#) [122A11089X](#) [122A13089X](#) [122A10089X](#) [122A10129X](#) [122A10349X](#)
[122A13359X](#) [1377391-4](#) [DIN-048CPC-SR1-MH](#) [1393583-2](#) [1393726-7](#) [140X10129X](#) [143-1913-000](#) [143-1908-000](#) [1484472-1](#) [2110070-1](#)
[2110070-2](#) [CBC20T00-008FDS5-0-1-002VR](#) [172699-5036](#) [2-1393557-4](#) [2-1437084-2](#) [CTJ720E01B-6141](#) [394506](#) [419-2080-402](#)
[V42254B2202C968](#) [419-2086-201](#) [419-2087-002](#) [448657-1](#) [448847-3](#) [5-1393755-9](#) [02990000004](#) [054302](#) [043556](#) [09062483201750](#)
[0850033067](#) [09031646555](#) [09061486901840](#)