



DIN Signal female connector - NFF



General information

Design	IEC 60603-2	types: B, 2B, C, 2C, M female		
No. of contacts	max. 96			
Contact spacing	2,54 mm			
Test voltage	1000V			
Contact resistance	max. 20mOhm			
Insulation resistance	min. 10 ⁹ Ohm			
Working current	2A at 20°C (see derating diagram)	40A for type M		
Temperature range	-55°C ... +125°C	or press-in connectors (due to limitations of PCB-material)		
Termination technology	press-in, solder pins			
Clearance & creepage distance	min. 1,2 mm each			
Insertion and withdrawal force	16-pole max. 15N	20-pole max. 20N	30-pole max. 30N	32-pole max. 30N
	48-pole max. 45N	64-pole max. 60N	96-pole max. 90N	
Mating cycles	PL 1 acc. to IEC 60603-2	500 mating cycles		
	PL 2 acc. to IEC 60603-2	400 mating cycles		
RoHS - compliant	Yes			
Leadfree	Yes			
Hot plugging	No			

Insulator material

Material	PA (thermoplastics, glass fiber reinforcement 25%)
Color	RAL 7035 (light grey)
UL classification	UL 94-V0
Material group acc. IEC 60664-1	II (400 ≤ CTI < 600)
NFF classification	I2, F1

Contact material

Contact material	Copper alloy
Plating termination zone	Sn over Ni for solder, Ni for press-in
Plating contact zone	Au over PdNi over Ni

Derating diagram acc. to IEC 60512-5 (Current carrying capacity)

The current carrying capacity is limited by maximum temperature of materials for inserts and contacts including terminals.

The current capacity curve is valid for continuous, non interrupted current loaded contacts of connectors when simultaneous power on all contacts is given, without exceeding the maximum temperature.

Control and test procedures according to DIN IEC 60512-5

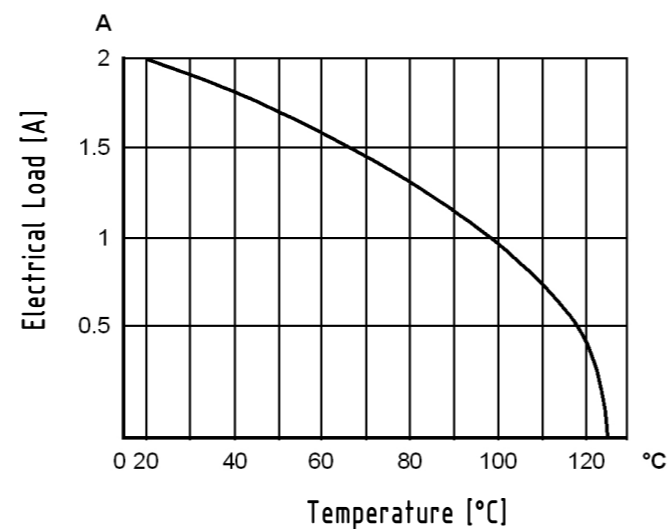

Recommended configuration of plated through holes for press-in termination

In addition to the hot-air-level (HAL), other PCB surfaces are getting more important. Due to their different properties - such as mechanical strength and coefficient of friction - we recommend the following configuration of PCB through holes.

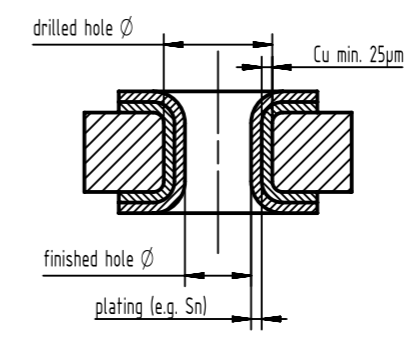

Plating	Drilled hole Ø	Plated hole Ø
Tin plated PCB (HAL) acc. to EN 60352-5	1,15±0,025 mm	max. 15 µm
		0,94 - 1,09 mm
Chemical tin plated PCB	1,15±0,025 mm	min. 0,8µm
		1,00 - 1,10 mm
Gold /Nickel plated PCB	1,15±0,025 mm	3 - 7 µm
		0,05 - 0,12 µm
		1,00 - 1,10 mm
Silver plated PCB	1,15±0,025 mm	0,1 - 0,3 µm
		1,00 - 1,10 mm
Copper plated PCB (OSP)	1,15±0,025 mm	1,00 - 1,10 mm
		1,00 - 1,10 mm

Assembly instructions

It is highly recommended to use HARTING press-in tools to ensure a reliable press-in process. Please refer to the catalogue for tools, machines and further information about the press-in process.

Soldering instructions

The connectors should be protected when being soldered in a dip, flow or film soldering baths. Otherwise, they might become contaminated as a result of soldering operations or deformed as a result of overheating.

(1) For prototypes and short runs protect the connectors with an industrial adhesive tape, e.g. Tesaband 4331 (www.tesa.de). Cover the underside of the connector moulding and the adjacent parts of the pcb as well as the open sides of the connector. This will prevent heat and gases of the soldering apparatus from damaging the connector. About 140 + 5 mm of the tape should suffice.

(2) For large series a jig is recommended. Its protective cover with a fast action mechanical locking device shields the connectors from gas and heat generated by the soldering apparatus. As an additional protection a foil can be used for covering the parts that should not be soldered.

Cross section of solder terminations

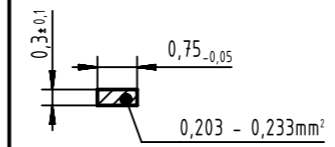

	All rights reserved	Created by HAGEMEYERE	Inspected by TADJE	Standardisation HOFFMANN	Date 2014-09-10	State Final Release
	Department EC PD - DE	Title DIN Signale female connector - NFF		Doc-Key / ECM-Nr. 100580364/UGD/000/A 50000076066		
HARTING Electronics GmbH D-32339 Espelkamp		Type DS	Number 09032120001		Rev. A	Page 1/1

X-ON Electronics

Largest Supplier of Electrical and Electronic Components

Click to view similar products for [DIN 41612 Connectors](#) category:

Click to view products by [HARTING](#) manufacturer:

Other Similar products are found below :

[09231126901](#) [PCN10F-24P-2.54DS\(72\)](#) [004.767](#) [02221602702](#) [024069](#) [602427301412000](#) [013275](#) [691327-1](#) [74670-0732](#) [74680-0340](#)
[75880-0015](#) [76453-0014](#) [86093159ALF](#) [923454](#) [QLC260R](#) [120X10099X](#) [120X10019X](#) [120X10089X](#) [120X10129X](#) [121A10039X](#)
[121A10309X](#) [122A10019X](#) [122A10029X](#) [122A10249X](#) [122A10669X](#) [122A11089X](#) [122A13089X](#) [121B10409X](#) [122A10089X](#)
[122A10129X](#) [122A10349X](#) [122A13359X](#) [1377391-4](#) [DIN-048CPC-SR1-MH](#) [1393583-2](#) [1393726-7](#) [140X10059X](#) [140X10129X](#) [143-1913-](#)
[000](#) [143-1908-000](#) [1484472-1](#) [173052](#) [2110070-1](#) [2110070-2](#) [CBC20T00-008FDS5-0-1-002VR](#) [983-0SE12-12P6](#) [17041102202](#) [172699-](#)
[5036](#) [173051](#) [20](#) [8457096](#) [010](#) [025](#)