

**GENERAL INFORMATION**

No. of contacts	from 6 to 100poles, all even numbers
Contact spacing	1,27mm x 1,27mm [0,050"x0,050"]
Test Voltage	500V
Contact resistance	< 25 mOhm
Insulation resistance	≥ 10x10 <sup>9</sup> Ω
Working current acc. to IEC 60512, at 70°C, 80% derating	see derating diagram
Working temperature range	-55°C ... +125°C
Termination technology	IDC
Clearance & creepage distance	0,4mm min.
Insertion force (depending on mating connector)	approximately 0,5N/contact
Withdrawal force (depending on mating connector)	approximately 0,5N/contact
Mating cycles	PL1 : 500 mating cycles PL2 : 250 mating cycles
RoHS - compliant	Yes
Leadfree	Yes
Working voltage acc. to IEC 60664-1	100V / 150V (depending on installation category)
UL file acc. UL 1977	ECBT2.E102079
UL file acc. CSA-C22.2 (for Canada)	ECBT8.E102079

**INSULATOR MATERIAL**

Material	LCP (liquid crystalline polymer)
Color	Black
UL classification	UL94-V0
Material group acc. IEC 60664-1	IIIa (175 ≤ CTI < 400)

**CONTACT MATERIAL**

Contact material	Copper alloy
Plating termination zone	Sn
Plating contact sliding side	Au over PdNi (acc. to Performance level)

**DERATING DIAGRAM acc. to IEC 60512-5 (Current carrying capacity)**

The current carrying capacity is limited by maximum temperature of materials for inserts and contacts including terminals.  
The current capacity curve is valid for continuous, non interrupted current loaded contacts of connectors when simultaneous power on all contacts is given, without exceeding the maximum temperature.

Control and test procedures according to DIN IEC 60512-5  
derating curve at I<sub>max</sub>\*0,8 (IEC 60512-5-2)

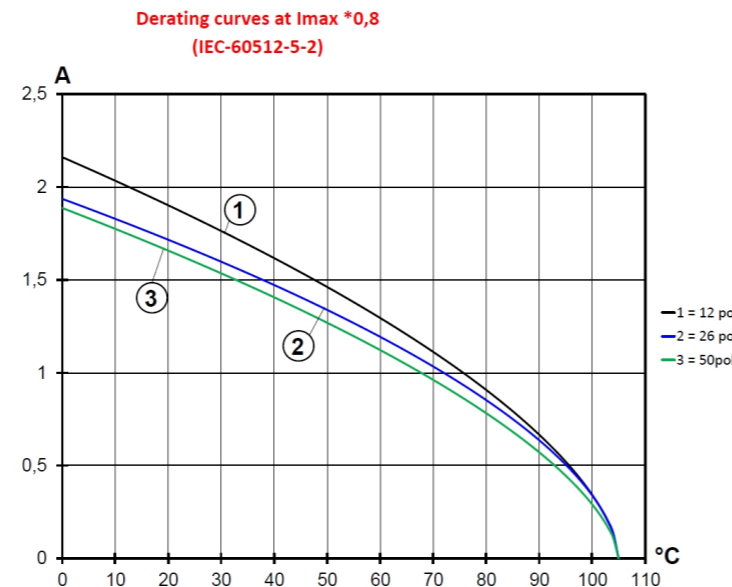

**CABLE ASSEMBLY REQUIREMENTS**

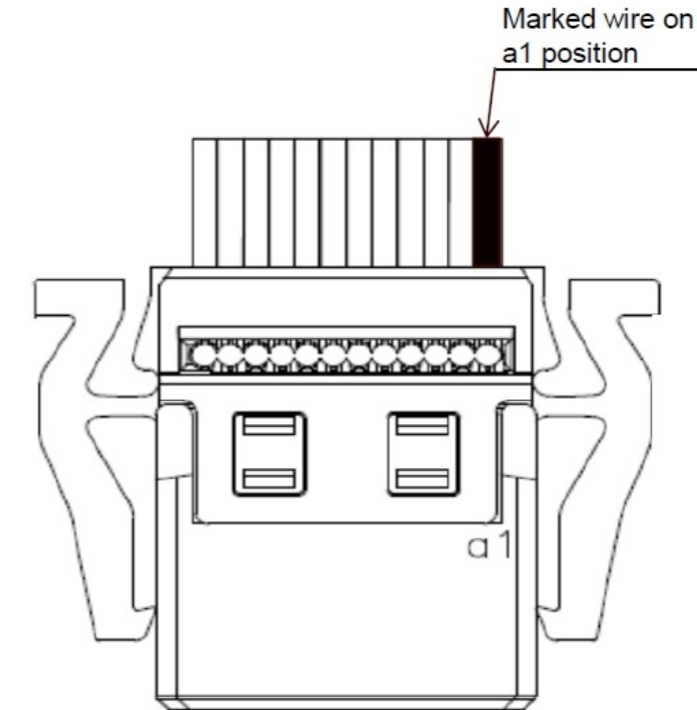

**FLAT CABLE REQUIREMENT FOR IDC CONNECTORS**

PVC flat cables	AWG 30/1 (solid) AWG 30/7 (stranded)
PTFE flat cables	AWG 30/1 (solid)
Insulation diameter	min 0,55mm - max 0,75 mm

**Important note :**

For an undisturbed operation of the cable assembly, please use a har-flex IDC cable connector on both ends of the cable. If you have to use a different cable connector beside one har-flex IDC cable connector, please, make sure to have the correct pin assignment of the ribbon cable wires according to this data sheets.

	All Dimensions in mm Original Size DIN A3	Scale 1:1	Free size tol.	Ref.
	All rights reserved Department EC PD - CN	Created by ZHUANGJ	Inspected by LUOK	Standardisation KOHLER
HARTING Electronics GmbH D-32339 Espelkamp	Title har flex female IDC			Doc-Key / ECM-Nr. 100578170/UGD/000/B 500000126530
	Type DS	Number 15292100601	Date 2017-10-13	State Final Release
				Rev. B Page 1/2



har-flex female IDC



PACKAGING

2-5 fully filled connector trays (depending on pin counts) with optional strain relief bottom tray

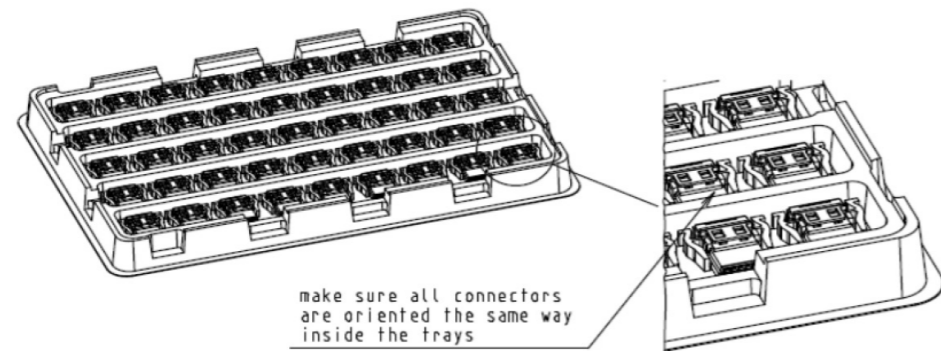
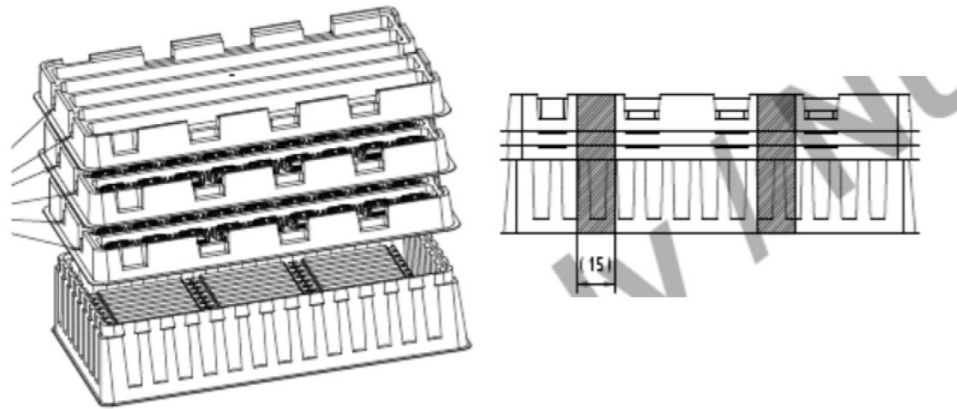

Pin count	Number of trays	Connectors per tray	Connectors per package
6	2	65	130
8	2	55	110
10	2	50	100
12	2	50	100
14	2	45	90
16	3	40	120
18	3	40	120
20	3	35	105
22	3	35	105
24	4	30	120
26	4	30	120
28	4	30	120
30	4	25	100
32	4	25	100
34	4	25	100
36	4	25	100
38	5	20	100
40	5	20	100
42	5	20	100
44	5	20	100
46	5	20	100
48	5	20	100
50	5	15	75
52	5	15	75
54	5	15	75
56	5	15	75
58	5	15	75
60	5	15	75
62	5	15	75
64	5	15	75
66	5	15	75
68	5	15	75
70	5	10	50
72	5	10	50
74	5	10	50
76	5	10	50
78	5	10	50
80	5	10	50
82	5	10	50
84	5	10	50
86	5	10	50
88	5	10	50
90	5	10	50
92	5	10	50
94	5	10	50
96	5	10	50
98	5	10	50
100	5	10	50

OPTIONNAL STRAIN RELIEF

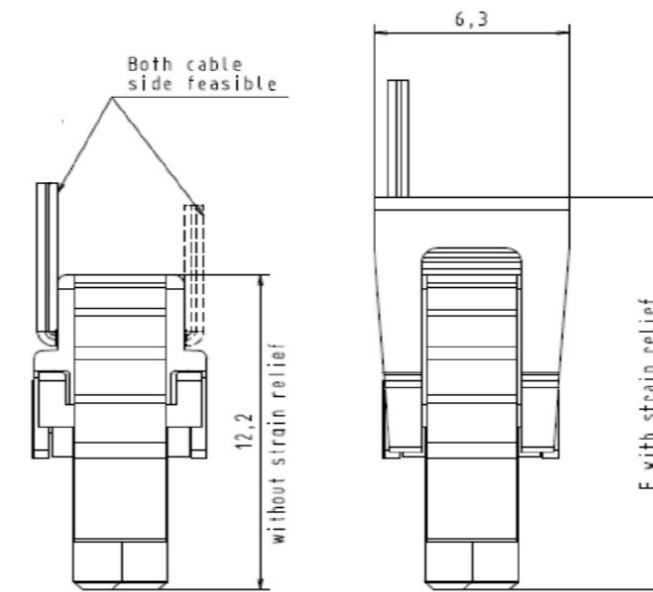
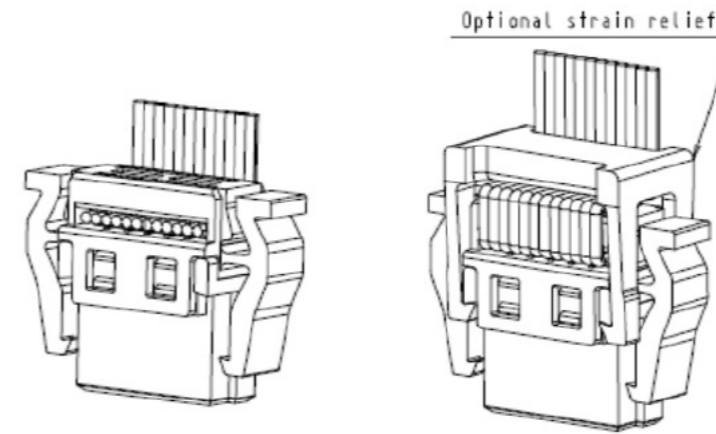

Pin count	E (mm)
6 to 58 pins	15
60 to 100 pins	16.2

Bottom tray for Strain relief

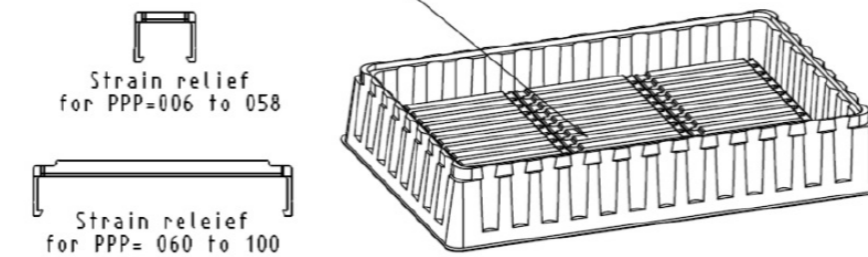

	All Dimensions in mm Original Size DIN A3	Scale 1:1	Free size tol.	Ref.	
	All rights reserved Department EC PD - CN	Created by ZHUANGJ	Inspected by LUOK	Standardisation KOHLER	Date 2017-10-13
HARTING Electronics GmbH D-32339 Espelkamp		Title har flex female IDC		State Final Release	
		Type DS	Number 15292100601	Doc-Key / ECM-Nr. 100578170/UGD/000/B 500000126530	Rev. B
				Page 2/2	

## X-ON Electronics

Largest Supplier of Electrical and Electronic Components

*Click to view similar products for [Headers & Wire Housings](#) category:*

*Click to view products by [HARTING](#) manufacturer:*

Other Similar products are found below :

[892-18-020-10-001101](#) [58102-G61-06LF](#) [582553-1](#) [0009485154](#) [009176003701906](#) [0050291907](#) [LY20-4P-DT1-P1E-BR](#) [02.125.8002.8](#)  
[609-3404](#) [61062-3](#) [61082-181009](#) [622-3653LF](#) [63453-116](#) [636-1030](#) [636-1427](#) [636-3427](#) [636-4007](#) [641938-9](#) [641991-4](#) [644827-2](#) [65817-](#)  
[010LF](#) [65817-015LF](#) [65863-015LF](#) [66207-023LF](#) [67095-007LF](#) [67601157](#) [68645-018](#) [68648-049](#) [70.362.1628.0](#) [70-4210](#) [70-4226B](#) [70-](#)  
[4853B](#) [707-5020](#) [707-5028](#) [71.350.2428.0](#) [71961-016LF](#) [733-134](#) [733-162](#) [754199-000](#) [760-3052](#) [787-8014-00](#) [79531-3000](#) [FCN-360C032-](#)  
[B](#) [FCN-367T-T012/H](#) [FCN-723D010/2](#) [80.063.4001.1](#) [800-90-001-10-001000](#) [800-90-010-10-002000](#) [801-43-002-10-013000](#) [801-43-006-](#)  
[10-002000](#)