



# har-bus® HM male connector



## General information

|                                |  |                        |
|--------------------------------|--|------------------------|
| Design                         | IEC 61076-4-101  |                        |
| No. of contacts                | 55 - 220 signal (77 - 308 fully shielded); or customized |                        |
| Contact spacing                | 2,0mm  |                        |
| Test voltage                   | 750V AC  |                        |
| Contact resistance             | max. 20mOhm  |                        |
| Insulation resistance          | min. 10 <sup>10</sup> Ohm                                |                        |
| Working current                | 1A at 70°C   | (see derating diagram) |
| Temperature range              | -55°C ... +125°C   |                        |
| Termination technology         | press-in   |                        |
| Clearance & creepage distance  | 0,8 mm each for fixed connector                          |                        |
| Insertion and withdrawal force | insertion force per contact:                             | 0,75N max.             |
|                                | withdrawal force per contact:                            | 0,15N min.             |
| Mating cycles                  | acc. to performance level, see table below               |                        |
| UL file                        | E102079  |                        |
| RoHS - compliant               | Yes  |                        |
| Leadfree                       | Yes  |                        |

## Insulator material

|                                    |   |
|------------------------------------|---|
| Material                           | PC (Polycarbonate, glass fiber reinforcement 20%) |
| Colour                             | RAL 7032 (grey)                                   |
| UL classification                  | UL 94-V0  |
| Material group acc. to IEC 60664-1 | IIIa (175 ≤ CTI < 400)                            |
| NFF classification                 | I2, F1  |

## Contact material

|                        |  |
|------------------------|--|
| Contact material       | Copper alloy                               |
| Treatment contact zone | Bellcore recommended lubricant (PPE)       |
| Plating press-in zone  | Ni   |
| Plating contact zone   | acc. to performance level, see table below |

| performance level | mating cycles           |                                       | plating contact zone                              |
|-------------------|-------------------------|---------------------------------------|---|
|                   | acc. to IEC 61076-4-101 | complementary acc. to IEC 61076-4-101 |   |
| 1                 | 500                     |                                       | <i>Au over PdNi over Ni</i>                       |
| 2                 | 250                     |                                       | <i>Au over PdNi over Ni</i>                       |
| NM30 (S4)         |                         | 500                                   | min. 0,76µm (30pinch) noble metal (alloy) over Ni |
| Au30              |                         | 500                                   | min. 0,76µm (30pinch) Au over Ni                  |
| Au50              |                         | 500                                   | min. 1,27µm (50pinch) Au over Ni                  |

Standard plating options highlighted in *italic*, other plating options are available on request.

## Recommended configuration of plated through holes for press-in termination

In addition to the hot-air-level (HAL), other PCB surfaces are getting more important. Due to their different properties - such as mechanical strength and coefficient of friction - we recommend the following configuration of PCB through holes.

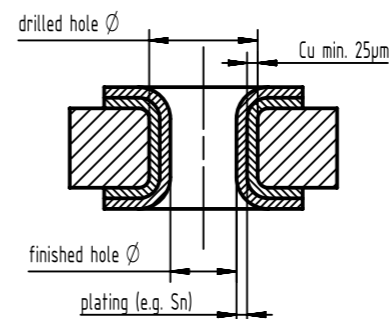

|   |                |               |
|---|----------------|---------------|
| Tin plated PCB (HAL) acc. to EN 60352-5 | Drilled hole Ø | 0,7±0,02mm    |
|   | Sn             | max. 15µm     |
|   | plated hole Ø  | 0,60 - 0,65mm |
| Chemical tin plated PCB                 | Drilled hole Ø | 0,7±0,02mm    |
|   | Sn             | min. 0,8µm    |
|   | plated hole Ø  | 0,60 - 0,65mm |
| Gold /Nickel plated PCB                 | Drilled hole Ø | 0,7±0,02mm    |
|   | Ni             | 3 - 7µm       |
|   | Au             | 0,05 - 0,12µm |
|   | plated hole Ø  | 0,60 - 0,65mm |
| Silver plated PCB                       | Drilled hole Ø | 0,7±0,02mm    |
|   | Ag             | 0,1 - 0,3µm   |
|   | plated hole Ø  | 0,60 - 0,65mm |
| Copper plated PCB (OSP)                 | Drilled hole Ø | 0,7±0,02mm    |
|   | plated hole Ø  | 0,60 - 0,65mm |

## Assembly instructions

It is highly recommended to use HARTING press-in tools to ensure a reliable press-in process. Please refer to the catalogue for tools, machines and further information about the press-in process.

## Circuit density

When using the specified diameter of the finished through hole according to IEC 61 076-4-101 (0.6 ± 0.05mm) with an appropriate annular ring, the remaining distance between the rings is about 1mm.

Under the condition that the width of the track and the space between should be equal, two tracks of 0.2mm width or three tracks of 0.14mm width can be placed between two rings.

Typical designs are shown in the drawing on the right side.

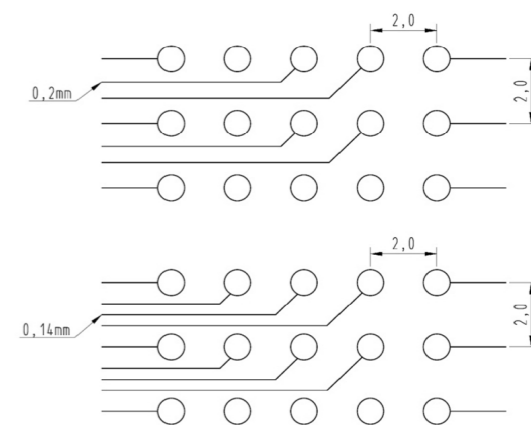

## Derating diagram acc. to IEC 60512-5 (Current carrying capacity)

The current carrying capacity is limited by maximum temperature of materials for inserts and contacts including terminals. The current capacity curve is valid for continuous, non interrupted current loaded contacts of connectors when simultaneous power on all contacts is given, without exceeding the maximum temperature.

Control and test procedures according to DIN IEC 60512-5

Curve 1 shows raise in temperature  
Curve 2 shows nominal derating Date Name  
Curve 3 shows reduced values as per IEC512

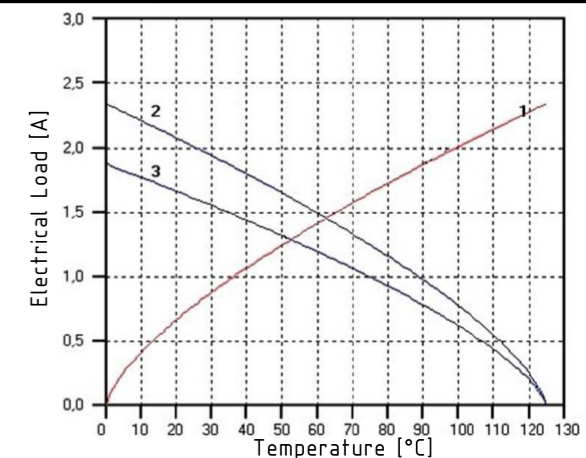

|                          |                       |                            |              |                 |                                     |               |
|--------------------------|-----------------------|----------------------------|--------------|-----------------|-------------------------------------|---------------|
|                          | All rights reserved   | Created by                 | Inspected by | Standardisation | Date                                | State         |
|                          | Department EC PD - DE | STORCK                     | LEHNERT      | HOFFMANN        | 2018-04-23                          | Final Release |
| HARTING Electronics GmbH |                       | Title                      |              |                 | Doc-Key / ECM-Nr.                   |               |
| D-32339 Espelkamp        |                       | har-bus® HM male connector |              |                 | 100580919/UGD/000/B<br>500000134078 |               |
|                          |                       | Type                       | Number       | Rev.            |                                     | Page          |
|                          |                       | DS                         | 17001100101  | B               |                                     | 1/1           |

## X-ON Electronics

Largest Supplier of Electrical and Electronic Components

*Click to view similar products for [Headers & Wire Housings](#) category:*

*Click to view products by [HARTING](#) manufacturer:*

Other Similar products are found below :

[892-18-020-10-001101](#) [58102-G61-06LF](#) [582553-1](#) [0009485154](#) [009176003701906](#) [0050291907](#) [LY20-4P-DT1-P1E-BR](#) [02.125.8002.8](#)  
[609-3404](#) [61062-3](#) [622-0430](#) [622-3653LF](#) [63453-116](#) [636-1030](#) [636-1427](#) [636-3427](#) [636-4007](#) [641938-9](#) [641991-4](#) [644827-2](#) [65817-010LF](#)  
[65817-015LF](#) [65863-015LF](#) [66207-023LF](#) [67095-007LF](#) [67601157](#) [68648-049](#) [70.362.1628.0](#) [70-4210](#) [70-4226B](#) [70-4853B](#) [707-5020](#) [707-](#)  
[5028](#) [71.350.2428.0](#) [71918-208LF](#) [71961-016LF](#) [733-134](#) [733-162](#) [754199-000](#) [760-3052](#) [787-8014-00](#) [79531-3000](#) [FCN-360C032-B](#) [FCN-](#)  
[367T-T012/H](#) [FCN-723D010/2](#) [80.063.4001.1](#) [800-90-001-10-001000](#) [800-90-010-10-002000](#) [801-43-002-10-013000](#) [801-43-006-10-002000](#)