

Customer Information Sheet

DRAWING No.: D3080-XX SHEET 2 OF 2

IF IN DOUBT - ASK

Ⓒ

NOT TO SCALE

THIRD ANGLE PROJECTION

ALL DIMENSIONS IN mm

ORDER CODE:

D3080-XX

FINISH:

00 = UNPLATED
01 = TIN
05 = GOLD
46 = 100% BRIGHT TIN

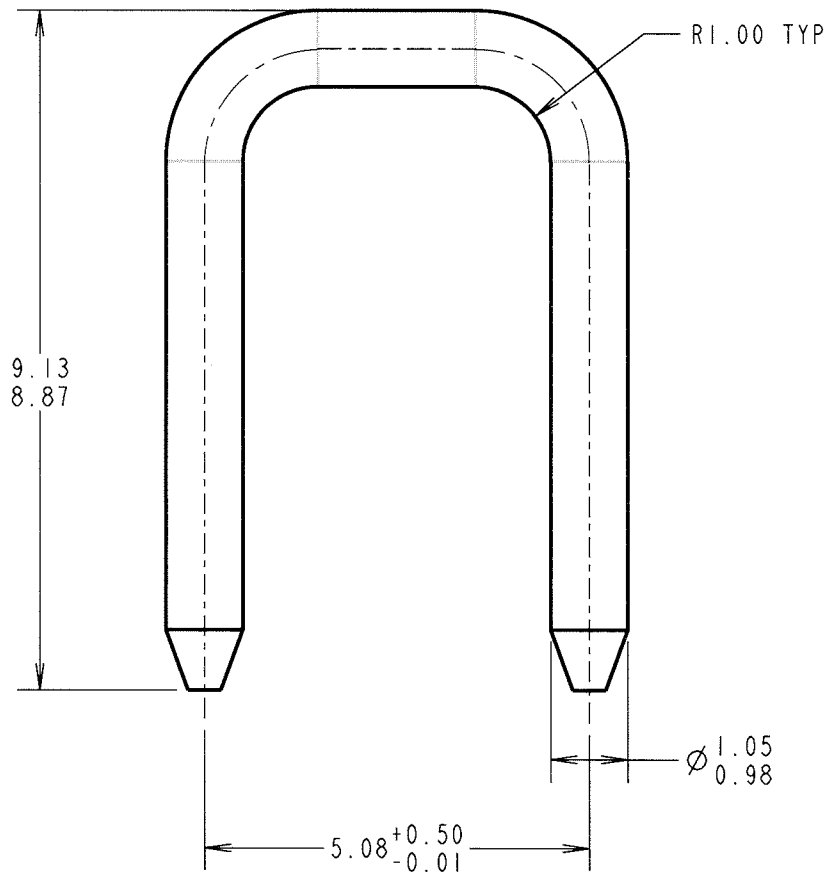

JAE	10	02.02.05	8356
NAME	ISS.	DATE	C/NOTE
APPROVED: <i>[Signature]</i>			
CHECKED: <i>[Signature]</i>			
DRAWN: C. HANSEN			
CUSTOMER REF.:			
ASSEMBLY DRG: D3086-XX			

HARWIN

THIS DRAWING AND ANY INFORMATION OR DESCRIPTIVE MATTER SET OUT HEREON ARE CONFIDENTIAL AND COPYRIGHT PROPERTY OF THE HARWIN GROUP AND MUST NOT BE DISCLOSED, LOANED, COPIED OR USED FOR MANUFACTURING, TENDERING OR FOR ANY OTHER PURPOSE WITHOUT THEIR WRITTEN PERMISSION.

TOLERANCES
X. = ±1mm
X.X = ±0.25mm
X.XX = ±0.10mm
X.XXX = ±0.01mm
ANGLES = ±5°
UNLESS STATED

MATERIAL:
BRASS CW606N TO BS EN 12164 (CuZn37Pb2)
FINISH: SEE ABOVE
S/AREA: mm²

TITLE:
1mm SHORTING LINK
DRAWING NUMBER:
D3080-XX

HARWIN INC U.S.A. TEL: (812) 542 2540 FAX: (812) 542 2541	HARWIN PLC U.K. TEL: 023 9231 4545 FAX: 023 9231 4590	HARWIN PTE SINGAPORE TEL: 65 6779 4909 FAX: 65 6779 3868
--	--	---

SHT
2
OF
2

Customer Information Sheet

DRAWING No.: D3081-XX

SHEET 2 OF 2

IF IN DOUBT - ASK

©

NOT TO SCALE

THIRD ANGLE PROJECTION

ALL DIMENSIONS IN mm

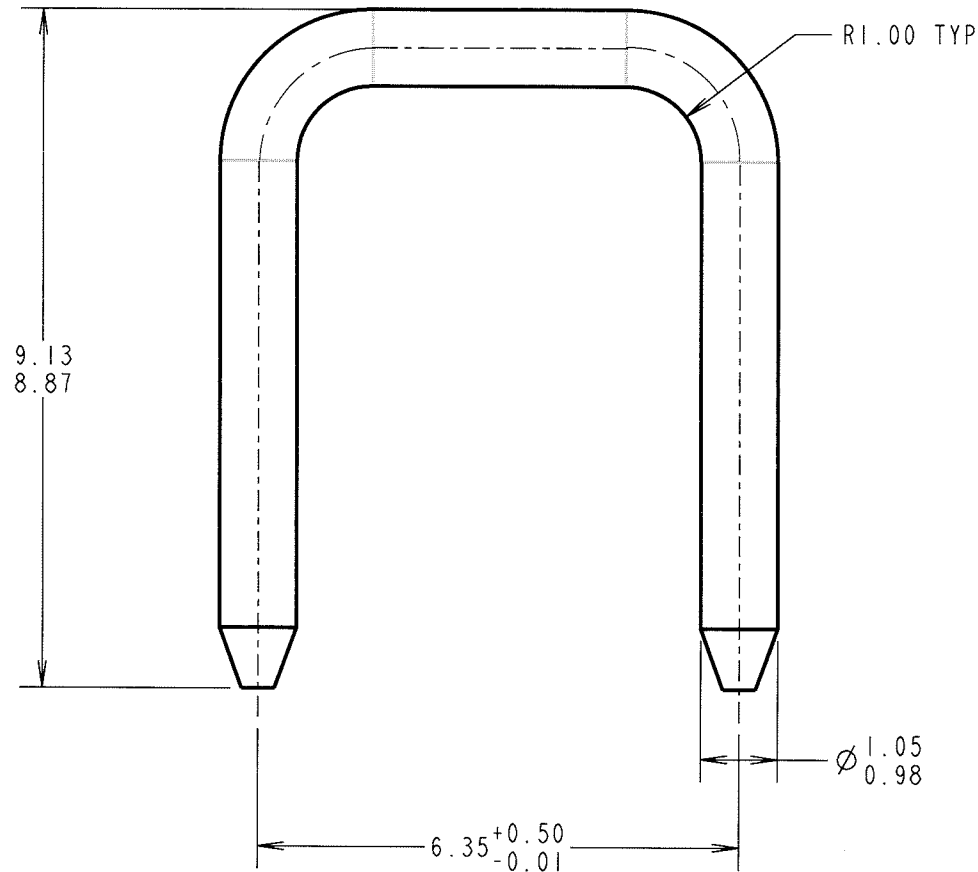

ORDER CODE:

D3081-XX

FINISH:

- 00 = UNPLATED
- 01 = TIN
- 05 = GOLD
- 46 = 100% BRIGHT TIN

JAE	9	02.02.05	8356
NAME	ISS.	DATE	C/NOTE
APPROVED: <i>[Signature]</i>			
CHECKED: <i>[Signature]</i>			
DRAWN: C. HANSEN			
CUSTOMER REF.:			
ASSEMBLY DRG: D3087-XX			

HARWIN

THIS DRAWING AND ANY INFORMATION OR DESCRIPTIVE MATTER SET OUT HEREON ARE CONFIDENTIAL AND COPYRIGHT PROPERTY OF THE HARWIN GROUP AND MUST NOT BE DISCLOSED, LOANED, COPIED OR USED FOR MANUFACTURING, TENDERING OR FOR ANY OTHER PURPOSE WITHOUT THEIR WRITTEN PERMISSION.

TOLERANCES

- X. = ±1mm
- X.X = ±0.25mm
- X.XX = ±0.10mm
- X.XXX = ±0.01mm

ANGLES = ±5°
UNLESS STATED

MATERIAL:

BRASS CW606N TO BS EN 12164 (CuZn37Pb2)

FINISH: SEE ABOVE

S/AREA: mm²

TITLE:

1mm SHORTING LINK

DRAWING NUMBER:

D3081-XX

SHT
2
OF
2

HARWIN INC
U.S.A.

TEL: (812) 542 2540
FAX: (812) 542 2541

HARWIN PLC
U.K.

TEL: 023 9231 4545
FAX: 023 9231 4590

HARWIN PTE
SINGAPORE

TEL: 65 6779 4909
FAX: 65 6779 3868

Customer Information Sheet

DRAWING No.: D3082-XX

SHEET 2 OF 2

IF IN DOUBT - ASK

©

NOT TO SCALE

THIRD ANGLE PROJECTION

ALL DIMENSIONS IN mm

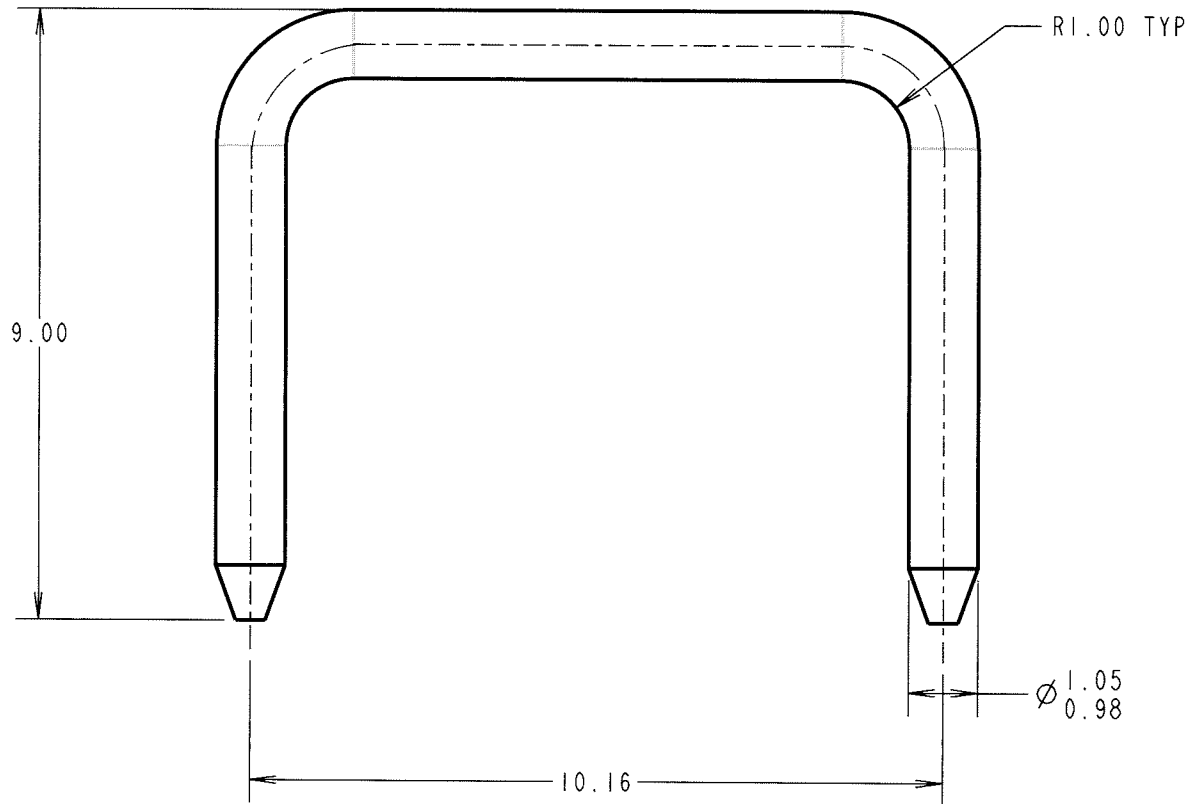

ORDER CODE:

D3082-XX

FINISH:

00 = UNPLATED
01 = TIN
05 = GOLD
46 = 100% BRIGHT TIN

JAE	9	02.02.05	8356
NAME	ISS.	DATE	C/NOTE
APPROVED: <i>ALL</i>			
CHECKED: <i>M. Hansen</i>			
DRAWN: C. HANSEN			
CUSTOMER REF.:			
ASSEMBLY DRG: D3088-XX			

HARWIN

THIS DRAWING AND ANY INFORMATION OR DESCRIPTIVE MATTER SET OUT HEREON ARE CONFIDENTIAL AND COPYRIGHT PROPERTY OF THE HARWIN GROUP AND MUST NOT BE DISCLOSED, LOANED, COPIED OR USED FOR MANUFACTURING, TENDERING OR FOR ANY OTHER PURPOSE WITHOUT THEIR WRITTEN PERMISSION.

TOLERANCES

X. = ±1mm
X.X = ±0.25mm
X.XX = ±0.10mm
X.XXX = ±0.01mm

ANGLES = ±5°

UNLESS STATED

MATERIAL:

BRASS CW606N TO BS EN 12164
(CuZn37Pb2)

FINISH: SEE ABOVE

S/AREA: mm²

TITLE:

1mm SHORTING LINK

DRAWING NUMBER:

D3082-XX

SHT
2
OF
2

HARWIN INC
U.S.A.

TEL: (812) 542 2540
FAX: (812) 542 2541

HARWIN PLC
U.K.

TEL: 023 9231 4545
FAX: 023 9231 4590

HARWIN PTE
SINGAPORE

TEL: 65 6779 4909
FAX: 65 6779 3868

Customer Information Sheet

DRAWING No.: D3083-XX

SHEET 2 OF 2

IF IN DOUBT - ASK

Ⓒ

NOT TO SCALE

THIRD ANGLE PROJECTION

ALL DIMENSIONS IN mm

ORDER CODE:

D3083-XX

FINISH:

- 00 = UNPLATED
- 01 = TIN
- 05 = GOLD
- 46 = 100% BRIGHT TIN

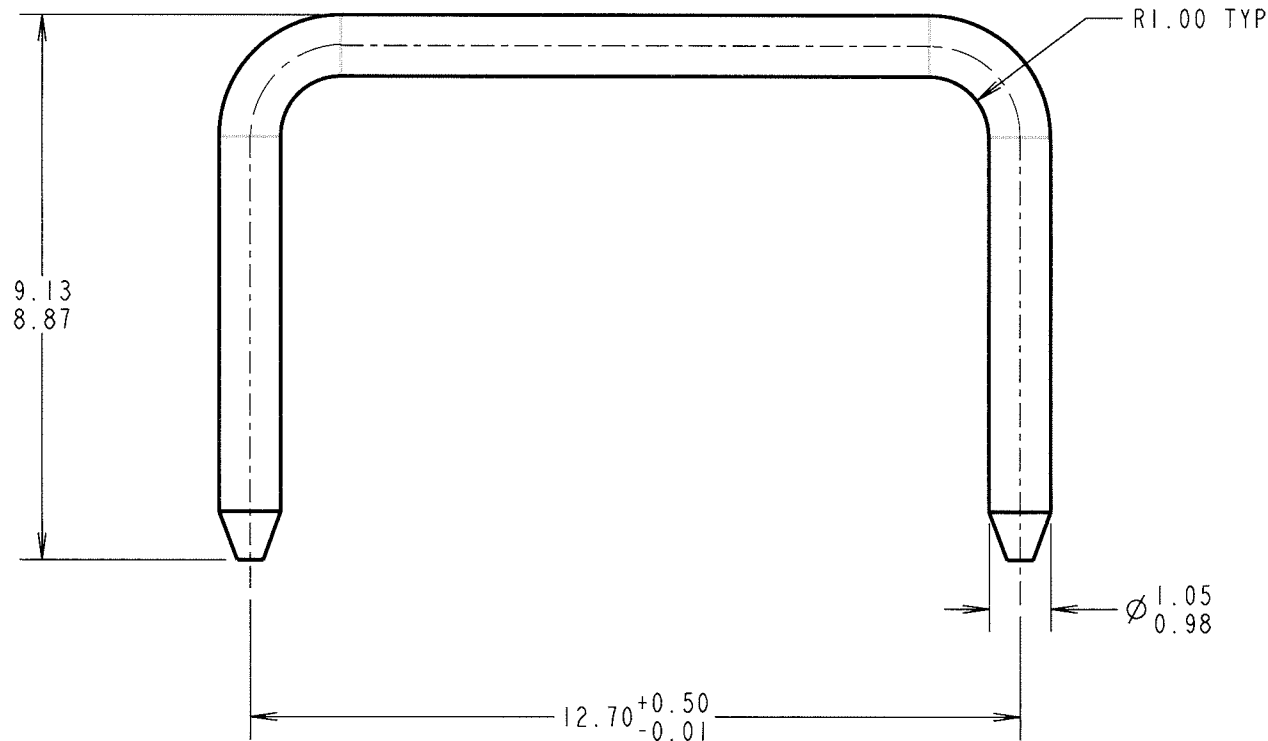

JAE	8	02.02.05	8356
NAME	ISS.	DATE	C/NOTE
APPROVED: <i>[Signature]</i>			
CHECKED: <i>[Signature]</i>			
DRAWN: C. HANSEN			
CUSTOMER REF.:			
ASSEMBLY DRG: D3089-XX			

HARWIN

THIS DRAWING AND ANY INFORMATION OR DESCRIPTIVE MATTER SET OUT HEREON ARE CONFIDENTIAL AND COPYRIGHT PROPERTY OF THE HARWIN GROUP AND MUST NOT BE DISCLOSED, LOANED, COPIED OR USED FOR MANUFACTURING, TENDERING OR FOR ANY OTHER PURPOSE WITHOUT THEIR WRITTEN PERMISSION.

TOLERANCES
 X. = ±1mm
 X.X = ±0.25mm
 X.XX = ±0.10mm
 X.XXX = ±0.01mm
 ANGLES = ±5°
 UNLESS STATED

MATERIAL:
 BRASS CW606N TO BS EN 12164
 (CuZn37Pb2)

TITLE:
 1mm SHORTING LINK

HARWIN INC U.S.A. TEL: (812) 542 2540 FAX: (812) 542 2541	HARWIN PLC U.K. TEL: 023 9231 4545 FAX: 023 9231 4590	HARWIN PTE SINGAPORE TEL: 65 6779 4909 FAX: 65 6779 3868
--	--	---

FINISH: SEE ABOVE
 S/AREA: mm²

DRAWING NUMBER:
D3083-XX

SHT
 2
 OF
 2

X-ON Electronics

Largest Supplier of Electrical and Electronic Components

Click to view similar products for [Circuit Board Hardware - PCB category](#):

Click to view products by [Harwin manufacturer](#):

Other Similar products are found below :

[8919-0-00-15-00-00-03-0](#) [0132-0-15-01-30-27-04-0](#) [0135-0-15-01-30-27-04-0](#) [5970-1-15-01-32-14-04-0](#) [0132-0-15-15-30-27-04-0](#) [0135-0-15-15-30-27-04-0](#) [0149-0-15-15-30-27-04-0](#) [MBI 1 BLUE](#) [7305-0-15-15-47-14-10-0](#) [MKU 1 BLACK](#) [MLN 150/1 BLACK](#) [8579-0-15-80-11-27-10-0](#) [8579-1-15-15-11-27-10-0](#) [8637-0-15-15-21-14-10-0](#) [8830-0-15-01-22-14-10-0](#) [8836-0-00-21-00-00-03-0](#) [PRUEF 2 RED](#) [9976-0-00-00-00-00-03-0](#) [1178-0-01-80-00-00-03-0](#) [PW1616](#) [1215-3-05-00-00-00-01-0](#) [1303-0-15-15-47-14-04-0](#) [1404-3](#) [1404-4](#) [1406-4](#) [1407-3](#) [1406-3](#) [1407-4](#) [1408-3](#) [1424-4](#) [1426-3](#) [1427-3](#) [1427-4](#) [1428-3](#) [1419-4](#) [1424-3](#) [1426-4](#) [1428-4](#) [MPS 1 BLACK](#) [1520150-1](#) [1548-103](#) [1801-0-15-15-30-27-04-0](#) [1938-0-00-00-00-00-03-0](#) [1942-0-00-00-00-00-03-0](#) [2101-3-00-44-00-00-07-0](#) [2104-2-01-44-00-00-07-0](#) [2108-2-00-50-00-00-07-0](#) [2108-3-00-44-00-00-07-0](#) [2109-2-00-44-00-00-07-0](#) [2110-2-00-44-00-00-07-0](#)