

Customer Information Sheet

DRAWING No.: G125-MS1XX05L0P

IF IN DOUBT - ASK

©

NOT TO SCALE

THIRD ANGLE PROJECTION

ALL DIMENSIONS IN mm

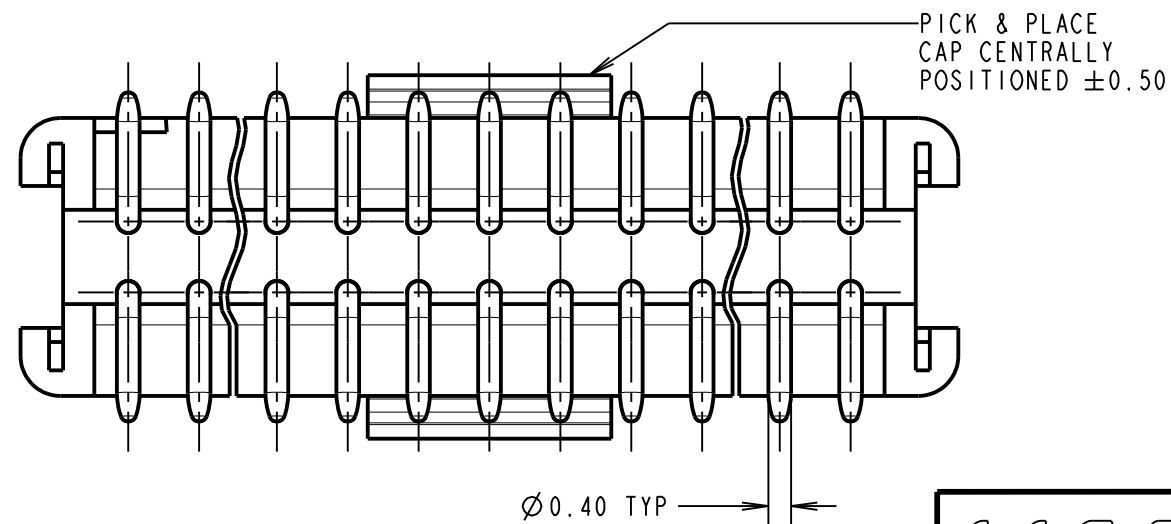
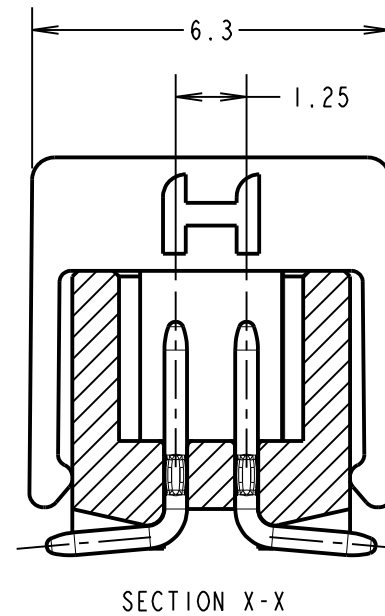
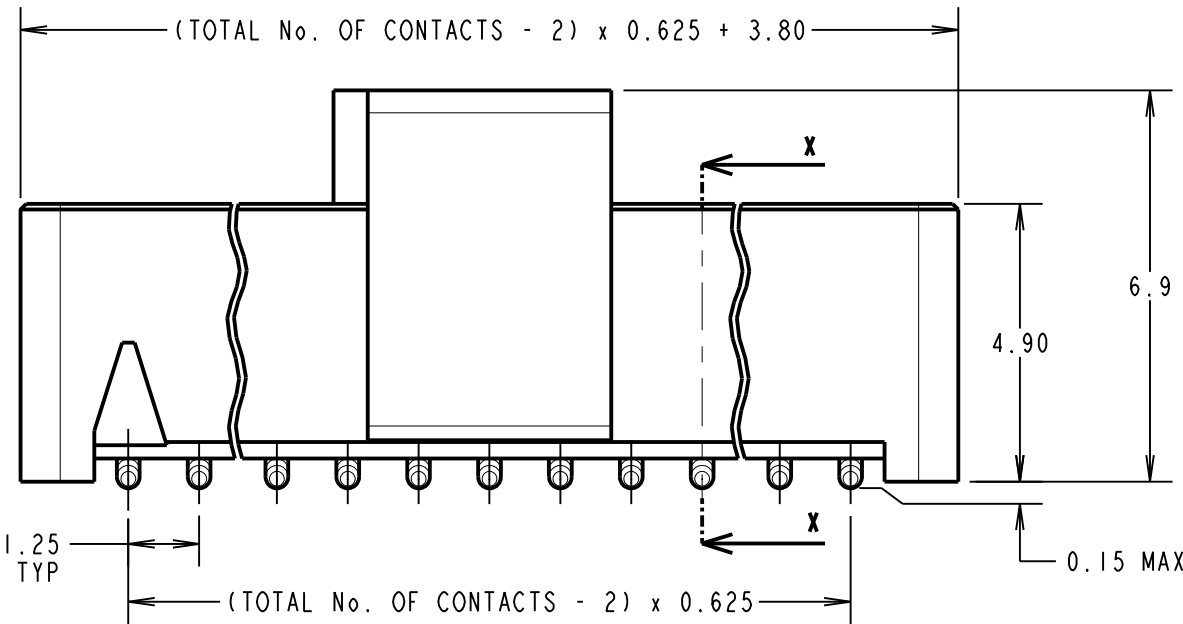
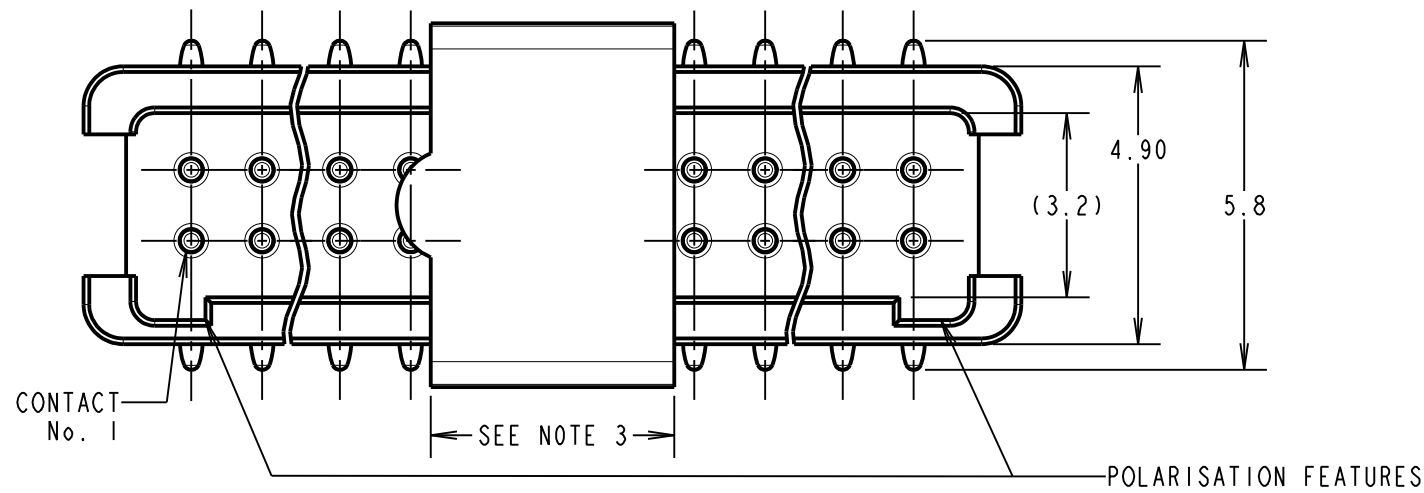

RECOMMENDED PCB LAYOUT - TOLERANCE = ±0.05

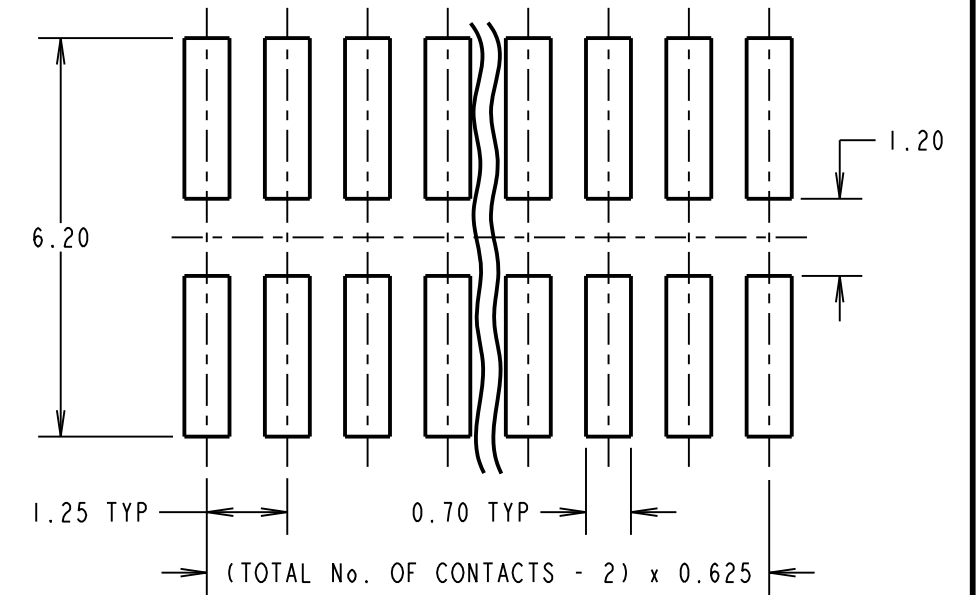

ORDER CODE: **G125-MS1XX05L0P**

TOTAL No. OF CONTACTS: 06, 10, 12, 16, 20, 26, 34, 50

CONNECTOR DETAILS AND PCB LAYOUT ONLY.
SEE SHEET 5 FOR TAPE STRIP DETAILS.

NOTES:

- FOR COMPLETE SPECIFICATION, SEE COMPONENT SPECIFICATION C125XX (LATEST ISSUE).
- CO-PLANARITY OF SMT TAILS NOT TO EXCEED 0.10mm. RECOMMENDED SOLDER PASTE THICKNESS = 0.125mm MIN.
- PICK AND PLACE CAP LENGTH = 4.3mm ON ALL PART NUMBERS EXCEPT G125-MS10605L0P ON THIS PART LENGTH = 3.3mm.

MGP	5	20.02.20	21885
NAME	ISS.	DATE	C/NOTE
APPROVED: MGP			
CHECKED: MR			
DRAWN: S.FLOWER			
CUSTOMER REF.:			
ASSEMBLY DRG:			

HARWIN

www.harwin.com
technical@harwin.com

THIS DRAWING AND ANY INFORMATION OR DESCRIPTIVE MATTER SET OUT HEREON ARE CONFIDENTIAL AND COPYRIGHT PROPERTY OF THE HARWIN GROUP AND MUST NOT BE DISCLOSED, LOANED, COPIED OR USED FOR MANUFACTURING, TENDERING OR FOR ANY OTHER PURPOSE WITHOUT THEIR WRITTEN PERMISSION.

TOLERANCES

X. = ±1mm
X.X = ±0.50mm
X.XX = ±0.20mm
X.XXX = ±0.01mm
ANGLES = ±5°
UNLESS STATED

MATERIAL:

SEE SPECIFICATION SHEET

FINISH: SEE SPECIFICATION SHEET

S/AREA: mm²

TITLE:

1.25mm GECKO MALE VERTICAL SMT CONNECTORS IN TAPE

DRAWING NUMBER:

G125-MS1XX05L0P

SHT
4
OF
5

Customer Information Sheet

DRAWING No.: G125-MS1XX05L0P

IF IN DOUBT - ASK

©

NOT TO SCALE

THIRD ANGLE PROJECTION

ALL DIMENSIONS IN mm

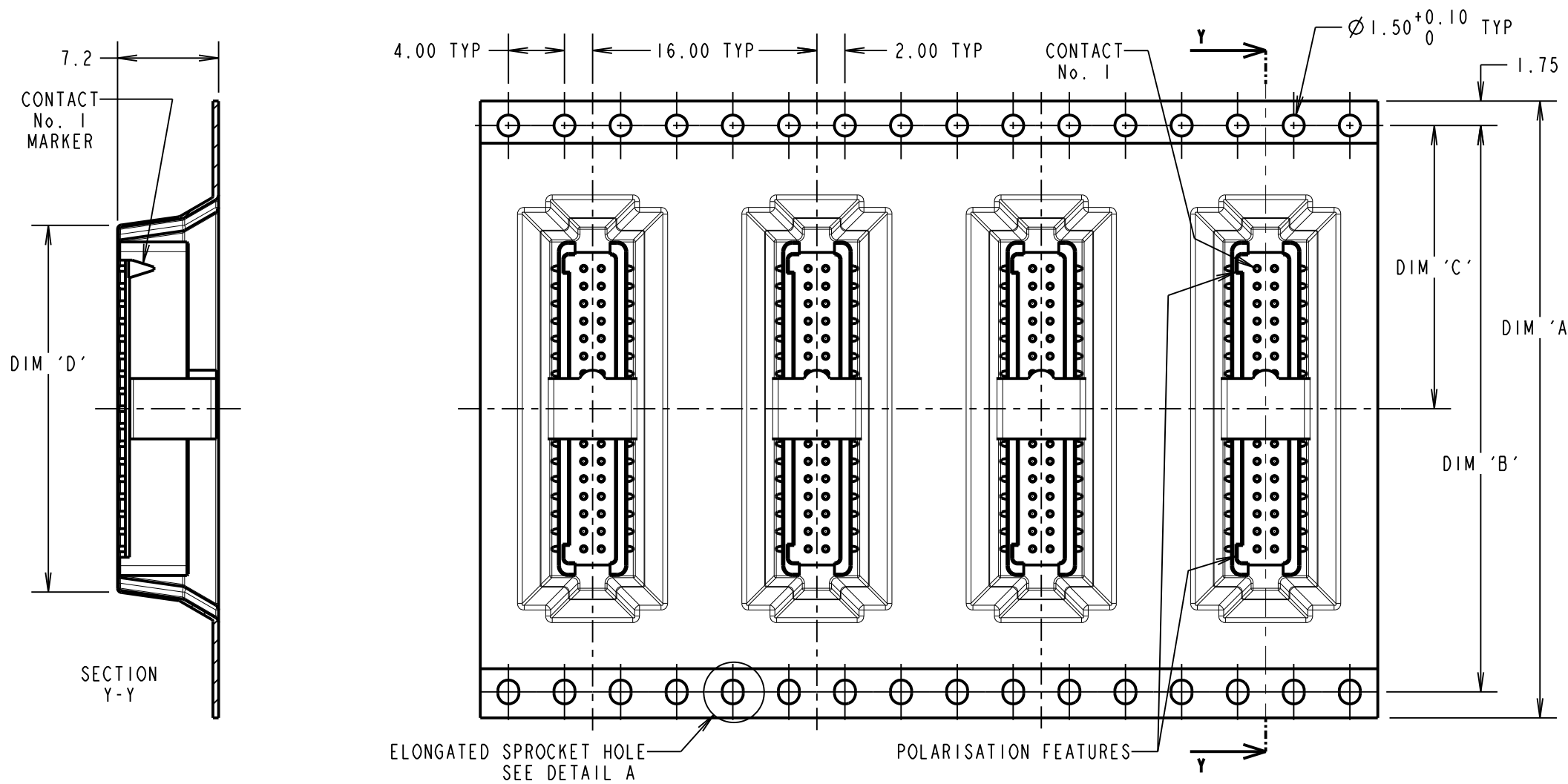

ORDER CODE: **G125-MS1XX05L0P**
 TOTAL No. OF CONTACTS: 06, 10, 12, 16, 20, 26, 34, 50

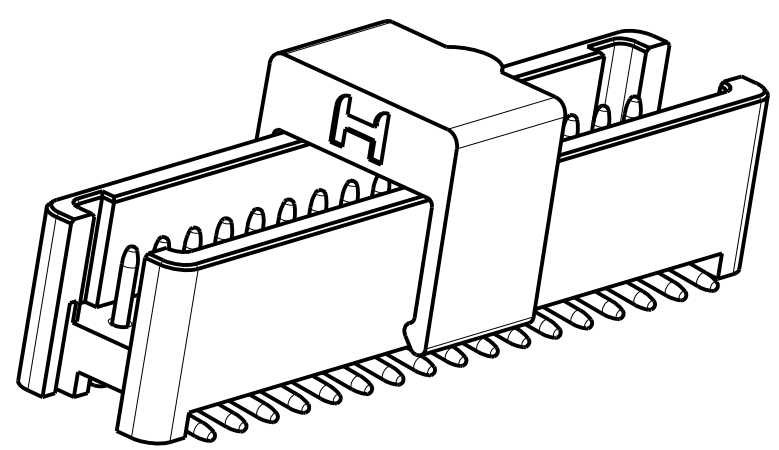
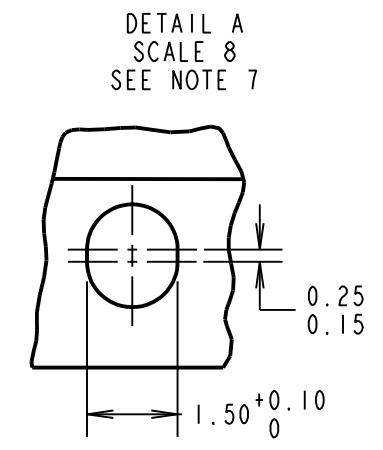

PART No.	DIM 'A'	DIM 'B'	DIM 'C'	(DIM 'D')
G125-MS10605L0P	24.0±0.3	NO ELONGATED HOLE	11.50	(8.6)
G125-MS11005L0P				(11.1)
G125-MS11205L0P	32.0±0.3	28.40	14.20	(12.4)
G125-MS11605L0P				(14.9)
G125-MS12005L0P	44.0±0.3	40.40	20.2±0.15	(17.4)
G125-MS12605L0P				(21.1)
G125-MS13405L0P	56.0±0.3	52.40	26.2±0.15	(26.1)
G125-MS15005L0P				(36.1)

MGP	5	20.02.20	21885
NAME	ISS.	DATE	C/NOTE
APPROVED: MGP			
CHECKED: MR			
DRAWN: S.FLOWER			
CUSTOMER REF.:			
ASSEMBLY DRG:			

- NOTES:
- COMPONENTS ARE ORIENTED IN TAPE POCKETS AS SHOWN.
 - COMPONENTS ARE SUPPLIED IN STRIPS OF TAPE. SUPPLIED QUANTITY MAY CONSIST OF MORE THAN ONE STRIP. STRIP LENGTH MAY VARY.
 - LARGE QUANTITIES MAY BE SHIPPED ON A REEL AND MAY NOT HAVE A LEADER.
 - FOR PARTS ON REEL SUITABLE FOR AUTOMATIC MACHINE PLACEMENT PLEASE ORDER: G125-MS1XX05L0R.
 - FOR COMPLETE SPECIFICATION, SEE COMPONENT SPECIFICATION C125XX (LATEST ISSUE).
 - COMPONENTS ARE ORIENTATED IN TAPE POCKETS SO THAT THE POLARISING FEATURES ARE FACING AWAY FROM THE FREE END.
 - ELONGATED SPROCKET HOLE NOT PRESENT ON 06 & 10 POSITIONS.

HARWIN
 www.harwin.com
 technical@harwin.com

THIS DRAWING AND ANY INFORMATION OR DESCRIPTIVE MATTER SET OUT HEREON ARE CONFIDENTIAL AND COPYRIGHT PROPERTY OF THE HARWIN GROUP AND MUST NOT BE DISCLOSED, LOANED, COPIED OR USED FOR MANUFACTURING, TENDERING OR FOR ANY OTHER PURPOSE WITHOUT THEIR WRITTEN PERMISSION.

TOLERANCES
 X. = ±1mm
 X.X = ±0.50mm
 X.XX = ±0.20mm
 X.XXX = ±0.01mm
 ANGLES = ±5°
 UNLESS STATED

MATERIAL:
 SEE SPECIFICATION SHEET
 FINISH: SEE SPECIFICATION SHEET
 S/AREA: mm²

TITLE:
 1.25mm GECKO MALE VERTICAL SMT CONNECTORS IN TAPE
 DRAWING NUMBER:
G125-MS1XX05L0P
 SHT 5 OF 5

Customer Information Sheet

DRAWING No.: G125-SERIES COMPONENT SPECIFICATION

IF IN DOUBT - ASK

Ⓒ

NOT TO SCALE

THIRD ANGLE PROJECTION

ALL DIMENSIONS IN mm

SPECIFICATIONS:

MATERIALS:

MOULDING, PICK & PLACE CAP:
POLYAMIDE, PA4T-GF30 FR(40) UL94V-0,
HALOGEN FREE, FREE OF RED PHOSPHORUS

CONTACTS:

SIGNAL CONTACTS:
MALE PC-TAIL/SMT = PHOSPHOR BRONZE
MALE CRIMP = BRASS
ALL FEMALE CONTACTS = BERYLLIUM COPPER
POWER CONTACTS:
ALL CONTACTS = BERYLLIUM COPPER

LOCKING HARDWARE:

LATCHES: COPPER NICKEL TIN ALLOY
SCREW LOCK: STAINLESS STEEL

BACK POTTING COMPOUND (CABLE ASSEMBLIES ONLY):
STYCAST 2651 MM BACK POTTING WITH CATALYST 9

FINISH:

ALL SIGNAL CONTACTS:
0.2-0.3µm GOLD OVER NICKEL
ALL POWER CONTACTS:
0.76-1.00µm GOLD OVER 1.50-2.50µm NICKEL
AND COPPER FLASH
LATCHES:
3.0µm 100% TIN OVER NICKEL

MECHANICAL:

DURABILITY = 1000 OPERATIONS
RETENTION IN HOUSING (ALL CONTACTS) = 6.0N MIN
SIGNAL CONTACTS:
INSERTION FORCE = 2.8N MAX
WITHDRAWAL FORCE = 0.2N MIN
POWER CONTACTS:
INSERTION FORCE = 7.0N MAX
WITHDRAWAL FORCE = 0.2N MIN
SCREW-LOK:
RETENTION IN HOUSING = 20.0N MIN
LATCHES:
RETENTION IN HOUSING = 4.0N MIN

ENVIRONMENTAL:

CLASSIFICATION: 65/150/56 DAYS AT 93% RH

TEMPERATURE RANGE:

* EIA-364-32 : 2000 TEST CONDITION IV, DWELL
30mins, 5 CYCLES -65°C TO +150°C

MECHANICAL:

VIBRATION AND SHOCK:

* EIA-364-28D : 1999: TEST CONDITION IV: VIBRATION SEVERITY:
10Hz TO 2000Hz, 1.5mm, 198mm/s² (20G). DURATION 2Hr
* EIA-364-28D : 1999: TEST CONDITION IV: VIBRATION SEVERITY:
10Hz TO 2000Hz, 1.5mm, 198mm/s² (20G). DURATION 2Hr
* EIA-364-27B : 1996: TEST CONDITION E SHOCK SEVERITY: 981mm/s²
(100G) FOR 6ms IN Z AXIS, 490mm/s² (50G) FOR 11m/s IN X & Y AXIS.
* EIA-364-01A : 2000: ACCELERATION: 490mm/s² (50G)
* BUMP SEVERITY: 390mm/s² (40G), 4000±10 BUMPS
* TESTED WITH LATCHED CONNECTORS

ELECTRICAL:

CURRENT RATING:

SIGNAL CONTACTS:

EIA-364-70A : 1998: INDIVIDUAL CONTACT IN ISOLATION AT 25°C = 2.8A MAX
EIA-364-70A : 1998: ALL CONTACTS SIMULTANEOUSLY AT 25°C = 2.0A MAX

POWER CONTACTS:

EIA-364-70A : 1998: PER CONTACT, THROUGH ALL CONTACTS = 10A MAX

CONTACT RESISTANCE:

EIA-364-06C : 2006: INITIAL CONTACT RESISTANCE = 20mΩ MAX
EIA-364-06C : 2006: CONTACT RESISTANCE AFTER CONDITIONING = 25mΩ MAX

VOLTAGE PROOF:

EIA-364-20C : 2004: SEA LEVEL (1013mbar) = 600V DC/AC PEAK
EIA-364-20C : 2004: ALTITUDE LEVEL (44mbar, 21,336m/70,000ft) = 350V DC/AC PEAK

WORKING VOLTAGE:

AT SEA LEVEL (1006mbar) = 450V DC/AC PEAK
AT ALTITUDE (44mbar, 21,336m/70,000ft) = 250V DC/AC PEAK

INSULATION RESISTANCE:

EIA-364-21C : 2000: INSULATION RESISTANCE (INITIAL)
= 10GΩ MIN AT 500V DC
EIA-364-21C : 2000: INSULATION RESISTANCE (AFTER CONDITIONING)
= >1GΩ MIN AT 500V DC

FOR FULL COMPONENT SPECIFICATION SEE C125XX (LATEST ISSUE).

RTP	5	04.10.19	22083
NAME	ISS.	DATE	C/NOTE
APPROVED:		R.PORTLOCK	
CHECKED:		S.BENNETT	
DRAWN:		S.FLOWER	
CUSTOMER REF.:			
ASSEMBLY DRG:			

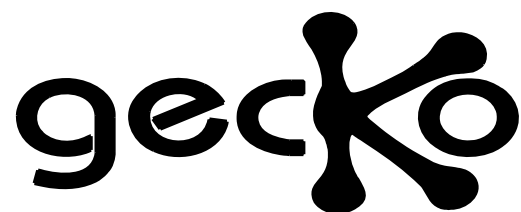

PATENTED TECHNOLOGY

HARWIN

www.harwin.com
technical@harwin.com

THIS DRAWING AND ANY INFORMATION OR DESCRIPTIVE MATTER SET OUT HEREON ARE CONFIDENTIAL AND COPYRIGHT PROPERTY OF THE HARWIN GROUP AND MUST NOT BE DISCLOSED, LOANED, COPIED OR USED FOR MANUFACTURING, TENDERING OR FOR ANY OTHER PURPOSE WITHOUT THEIR WRITTEN PERMISSION.

TOLERANCES

X. = ±1mm
X.X = ±0.50mm
X.XX = ±0.20mm
X.XXX = ±0.01mm
ANGLES = ±5°
UNLESS STATED

MATERIAL:

SEE ABOVE

FINISH:

SEE ABOVE

S/AREA:

mm²

TITLE:

G125 SERIES COMPONENT SPECIFICATION

DRAWING NUMBER:

G125-SERIES CONNECTORS

SHT
1 OF 1

X-ON Electronics

Largest Supplier of Electrical and Electronic Components

Click to view similar products for [Headers & Wire Housings](#) category:

Click to view products by [Harwin](#) manufacturer:

Other Similar products are found below :

[892-18-020-10-001101](#) [58102-G61-06LF](#) [582553-1](#) [0009485154](#) [009176003701906](#) [0050291907](#) [LY20-4P-DT1-P1E-BR](#) [02.125.8002.8](#)
[609-3404](#) [61062-3](#) [622-0430](#) [622-3653LF](#) [63453-116](#) [636-1030](#) [636-1427](#) [636-3427](#) [636-4007](#) [641938-9](#) [641991-4](#) [644827-2](#) [65817-010LF](#)
[65817-015LF](#) [65863-015LF](#) [66207-023LF](#) [67095-007LF](#) [67601157](#) [68648-049](#) [70.362.1628.0](#) [70-4210](#) [70-4226B](#) [70-4853B](#) [707-5020](#) [707-](#)
[5028](#) [71.350.2428.0](#) [71918-208LF](#) [71961-016LF](#) [733-134](#) [733-162](#) [754199-000](#) [760-3052](#) [787-8014-00](#) [79531-3000](#) [FCN-360C032-B](#) [FCN-](#)
[367T-T012/H](#) [FCN-723D010/2](#) [80.063.4001.1](#) [800-90-001-10-001000](#) [800-90-010-10-002000](#) [801-43-002-10-013000](#) [801-43-006-10-002000](#)