

# Customer Information Sheet

DRAWING No.: M20-781XX45X

SHEET 3 OF 4

IF IN DOUBT - ASK

©

NOT TO SCALE

THIRD ANGLE PROJECTION

ALL DIMENSIONS IN mm

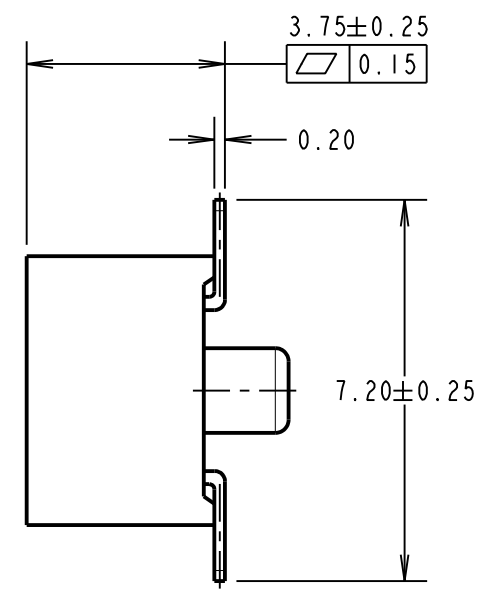
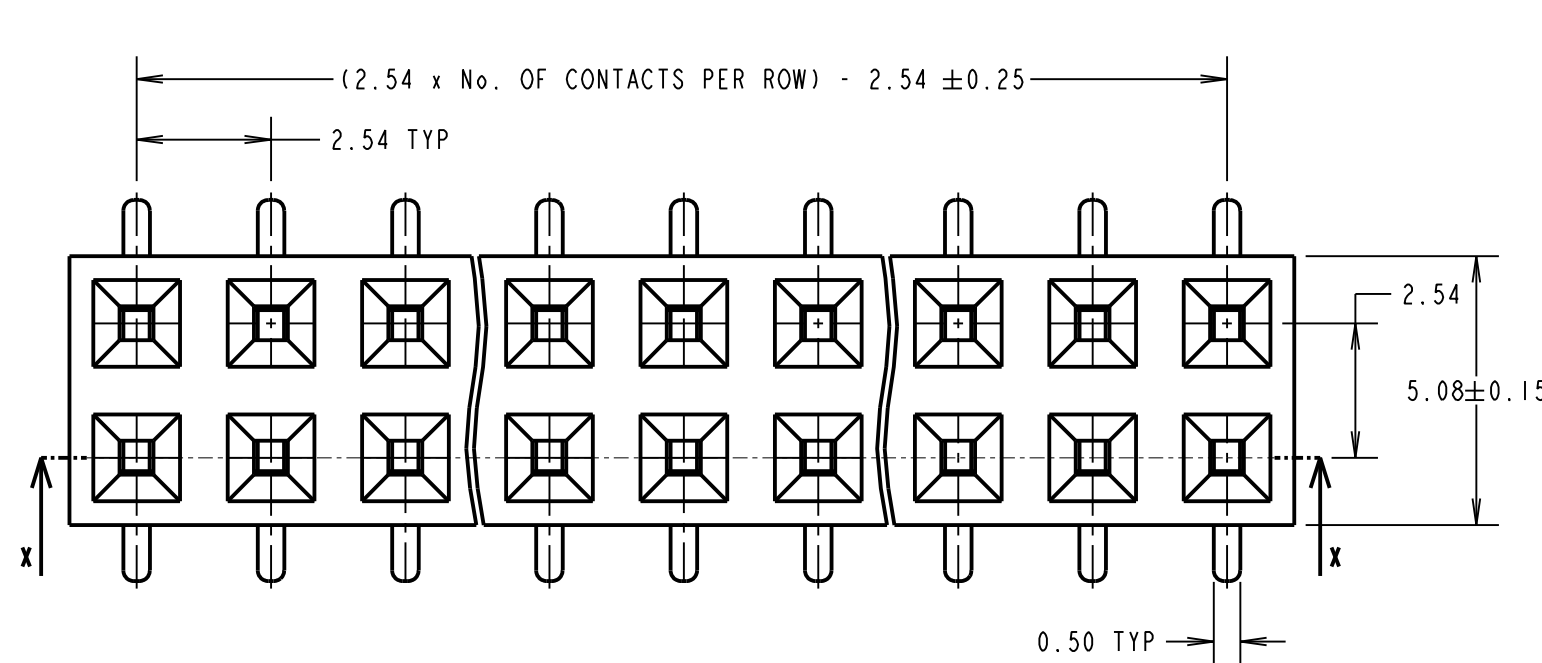

**SPECIFICATIONS:**

**MATERIAL:**  
 MOULD = GLASS FILLED PA9T, UL94V-0  
 CONTACTS = PHOSPHOR BRONZE  
**FINISH:**  
 0.015µ MIN GOLD OVER 0.76-2.03µ NICKEL  
**ELECTRICAL:**  
 CURRENT RATING = 3A  
 CONTACT RESISTANCE = 20mΩ MAX  
 INSULATION RESISTANCE = 1000MΩ MIN  
 VOLTAGE PROOF = 1000V AC FOR ONE MINUTE  
**MECHANICAL:**  
 INSERTION FORCE = 1.96N MAX PER CONTACT  
 WITHDRAWAL FORCE = 0.29N MIN PER CONTACT  
 DURABILITY = 300 CYCLES MIN  
**ENVIRONMENTAL:**  
 OPERATING TEMPERATURE = -40°C TO +105°C

ORDER CODE:

**M20-781XX45X**

No. OF CONTACTS PER ROW: \_\_\_\_\_  
 02-10, 12, 15 & 20

PACKING: \_\_\_\_\_  
 BLANK = TUBE  
 R = TAPE AND REEL (SHEET 4)

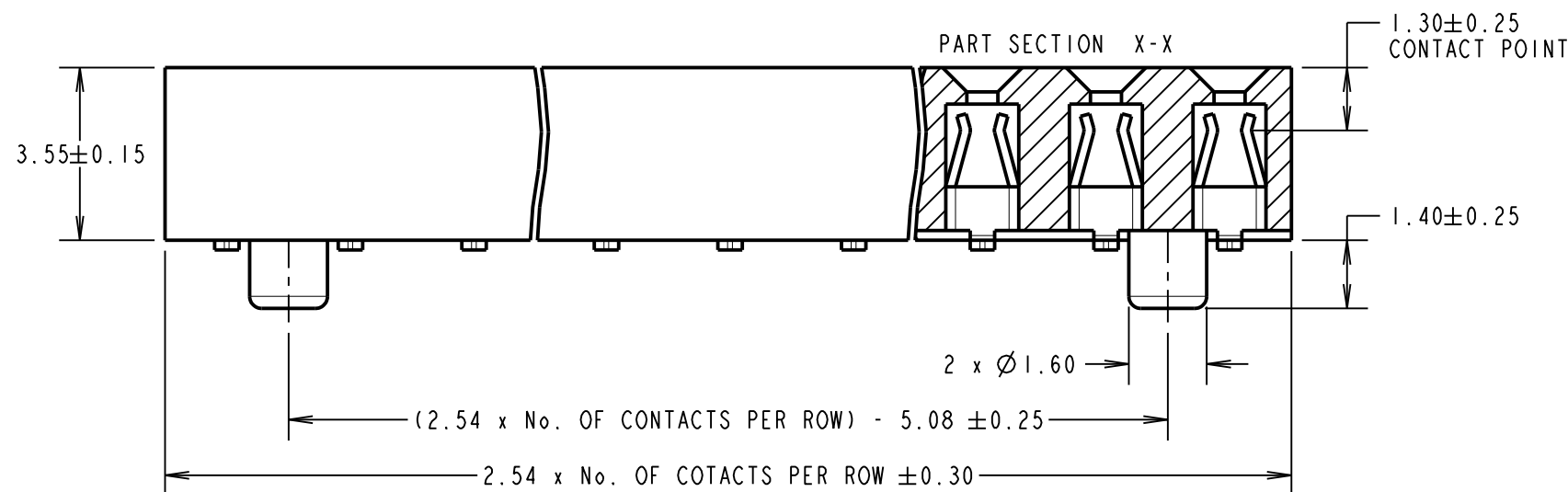

**RECOMMENDED PCB LAYOUT**  
 (TOLERANCE = ±0.05)

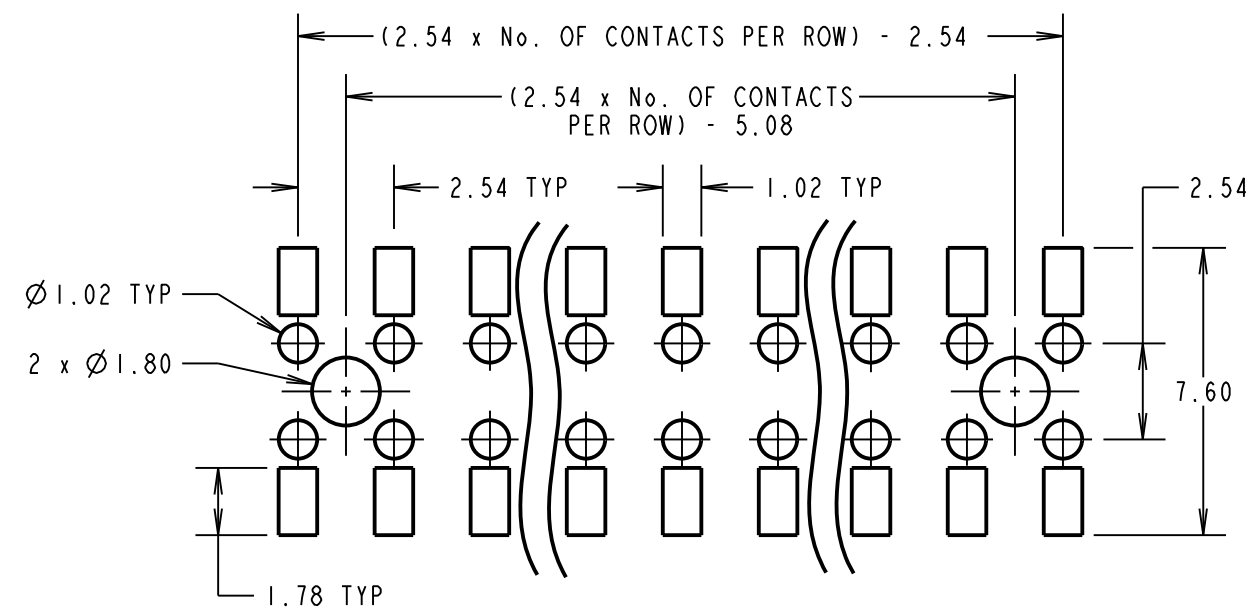

**NOTES:**

- CONTACT LEG VARIATION ON COMPLETE ASSEMBLY NOT TO EXCEED 0.10mm.
- FOR TAPE AND REEL DETAILS, SEE SHEET 4.

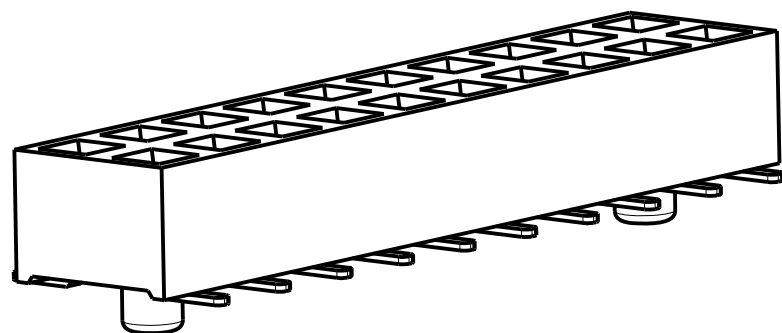

MSP	1	06.05.16	-----
NAME	ISS.	DATE	C/NOTE
APPROVED: M.PERREN			
CHECKED: S.BENNETT			
DRAWN: M.PERREN			
CUSTOMER REF.:			
ASSEMBLY DRG:			

**HARWIN**

www.harwin.com  
 technical@harwin.com

THIS DRAWING AND ANY INFORMATION OR DESCRIPTIVE MATTER SET OUT HEREON ARE CONFIDENTIAL AND COPYRIGHT PROPERTY OF THE HARWIN GROUP AND MUST NOT BE DISCLOSED, LOANED, COPIED OR USED FOR MANUFACTURING, TENDERING OR FOR ANY OTHER PURPOSE WITHOUT THEIR WRITTEN PERMISSION.

**TOLERANCES**  
 X. = ±1mm  
 X.X = ±0.50mm  
 X.XX = ±0.10mm  
 X.XXX = ±0.01mm  
 ANGLES = ±5°  
 UNLESS STATED

**MATERIAL:**  
 SEE ABOVE  
**FINISH:** SEE ABOVE  
**S/AREA:** mm<sup>2</sup>

**TITLE:**  
 2.54mm PITCH DIL LOW PROFILE SMT SOCKET WITH PEGS

**DRAWING NUMBER:**  
**M20-781XX45X**

SHT  
 3 OF 4

# Customer Information Sheet

DRAWING No.: M20-781XX45X

SHEET 4 OF 4

IF IN DOUBT - ASK

(C)

NOT TO SCALE

THIRD ANGLE PROJECTION

ALL DIMENSIONS IN mm

TAPE DETAILS FOR  
02, 03, 04 & 05 WAY

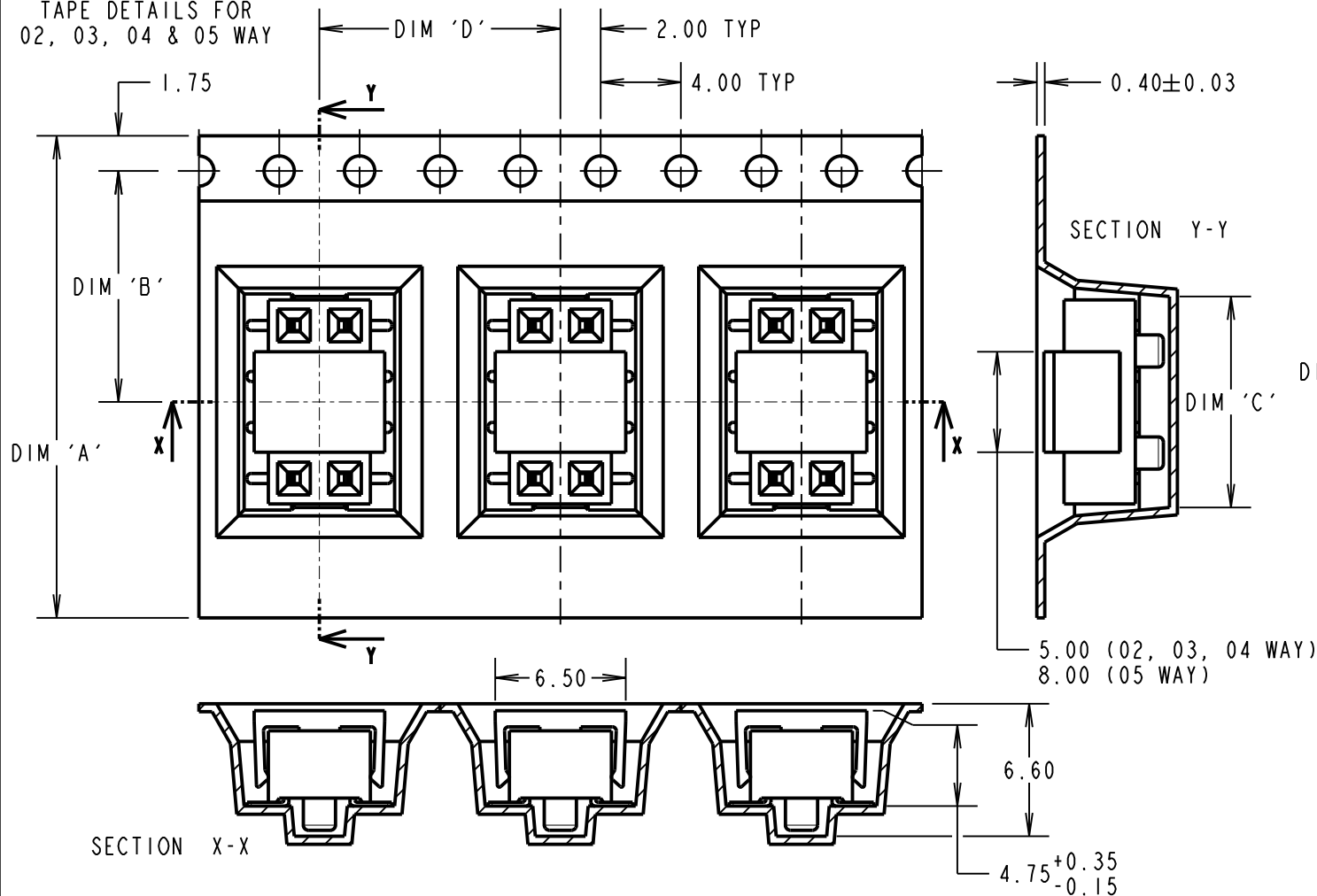

TAPE DETAILS FOR  
06, 07, 08, 09, 10, 12, 15 & 20 WAY

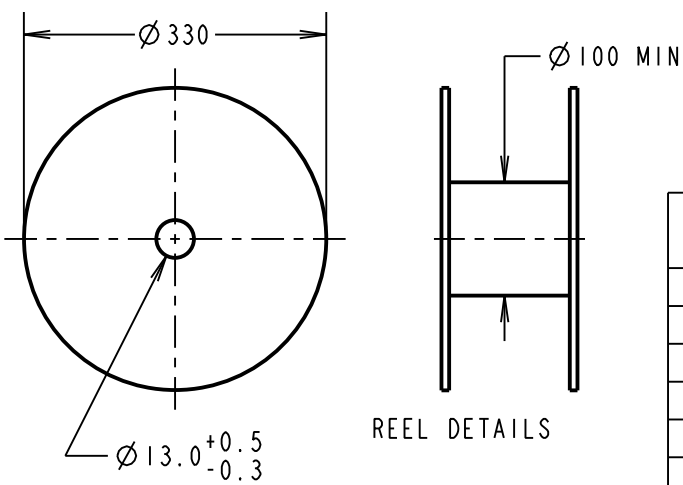
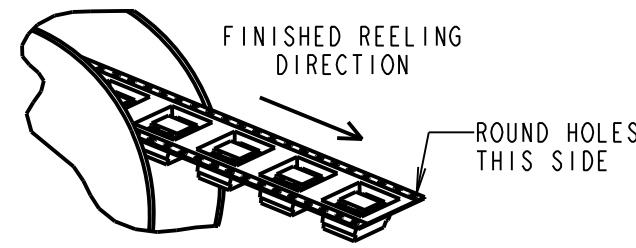
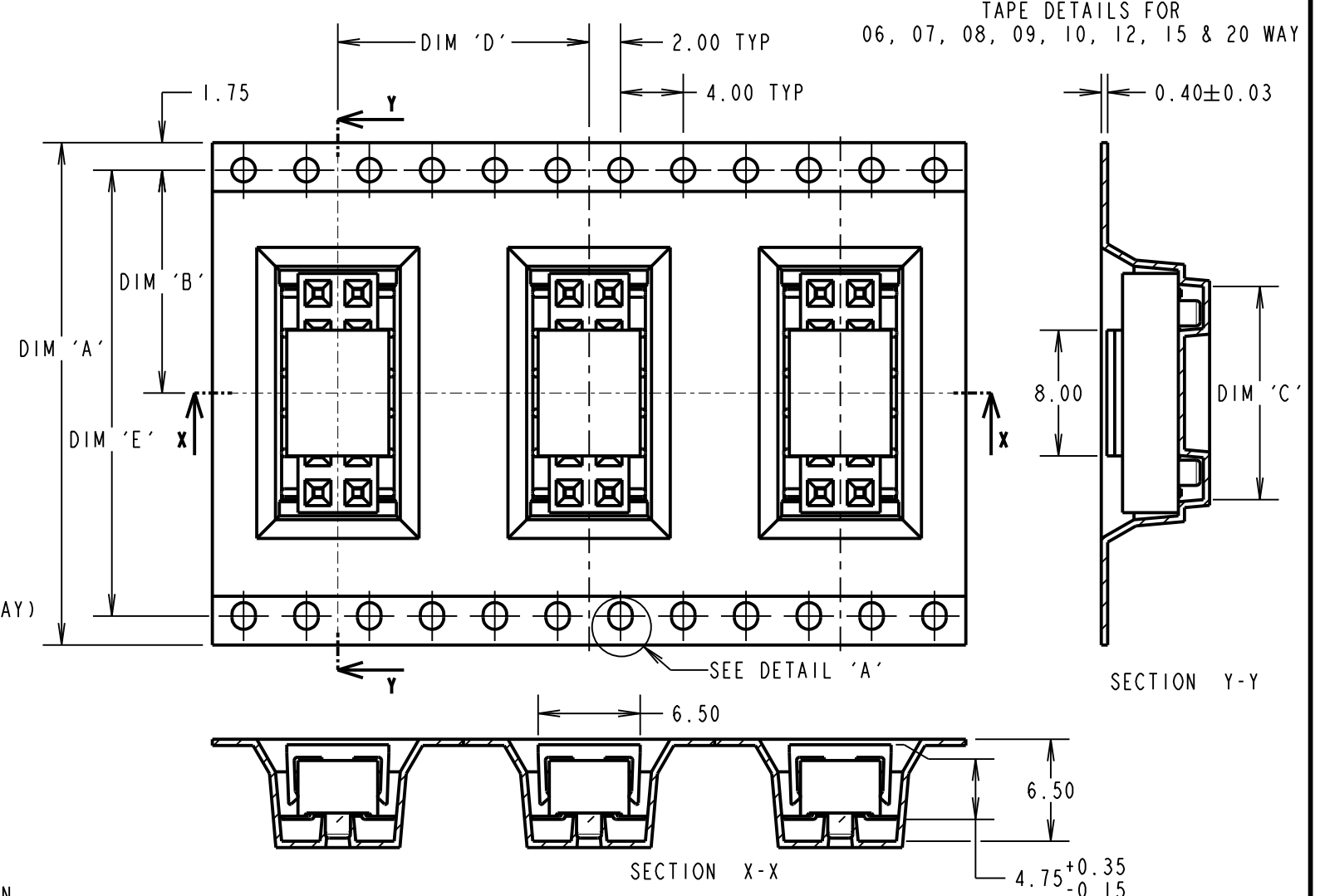

REEL DETAILS

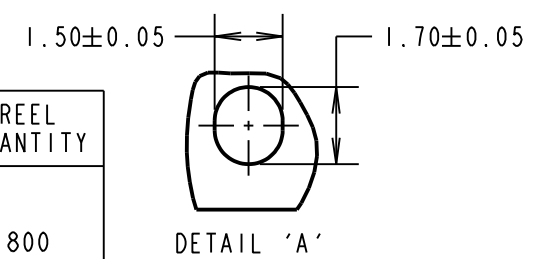

DETAIL 'A'

ORDER CODE:  
**M20-781XX45X**

No. OF CONTACTS PER ROW: \_\_\_\_\_  
02-10, 12, 15 & 20

PACKING: \_\_\_\_\_  
BLANK = TUBE (SHEET 3)  
R = TAPE AND REEL

PART No.	DIMENSION					REEL QUANTITY
	DIM 'A'	DIM 'B'	DIM 'C'	DIM 'D'	DIM 'E'	
M20-7810245R	16.00±0.30	7.50±0.15	5.40	12.00	N/A	800
M20-7810345R			8.00			
M20-7810445R	24.00±0.30	11.50	10.50	16.00	28.50	600
M20-7810545R			13.00			
M20-7810645R	32.00±0.30	14.20±0.15	15.65	16.00	40.40	600
M20-7810745R			18.08			
M20-7810845R			20.60	16.00	52.40	600
M20-7810945R	44.00±0.30	20.20±0.15	23.35			
M20-7811045R			25.80	12.00	68.40	600
M20-7811245R	56.00±0.30	26.20±0.15	30.90			
M20-7811545R			38.50	16.00	68.40	600
M20-7812045R	72.00±0.30	34.20±0.15	51.20			

MSP	1	06.05.16	----
NAME	ISS.	DATE	C/NOTE
APPROVED:		M.PERREN	
CHECKED:		S.BENNETT	
DRAWN:		M.PERREN	
CUSTOMER REF.:			
ASSEMBLY DRG:			

- NOTES:
- PRODUCT IS TAPE AND REELED IN GENERAL ACCORDANCE WITH EIA-481 (ELECTRICAL INDUSTRIES ASSOCIATION).
  - CONTACT LEG VARIATION ON COMPLETE ASSEMBLY NOT TO EXCEED 0.10mm.
  - FOR CONNECTOR DETAILS AND SPECIFICATIONS, SEE SHEET 3.

**HARWIN**

www.harwin.com  
technical@harwin.com

THIS DRAWING AND ANY INFORMATION OR DESCRIPTIVE MATTER SET OUT HEREON ARE CONFIDENTIAL AND COPYRIGHT PROPERTY OF THE HARWIN GROUP AND MUST NOT BE DISCLOSED, LOANED, COPIED OR USED FOR MANUFACTURING, TENDERING OR FOR ANY OTHER PURPOSE WITHOUT THEIR WRITTEN PERMISSION.

TOLERANCES  
X. = ±1mm  
X.X = ±0.50mm  
X.XX = ±0.10mm  
X.XXX = ±0.01mm  
ANGLES = ±5°  
UNLESS STATED

MATERIAL:  
SEE ABOVE

FINISH: SEE ABOVE

S/AREA: mm<sup>2</sup>

TITLE:  
2.54mm PITCH DIL LOW PROFILE SMT SOCKET WITH PEGS

DRAWING NUMBER:  
**M20-781XX45X**

SHT 4 OF 4

## X-ON Electronics

Largest Supplier of Electrical and Electronic Components

*Click to view similar products for [Headers & Wire Housings](#) category:*

*Click to view products by [Harwin](#) manufacturer:*

Other Similar products are found below :

[892-18-020-10-001101](#) [58102-G61-06LF](#) [582553-1](#) [0009485154](#) [009176003701906](#) [0050291907](#) [LY20-4P-DT1-P1E-BR](#) [02.125.8002.8](#)  
[609-3404](#) [61062-3](#) [622-0430](#) [622-3653LF](#) [63453-116](#) [636-1030](#) [636-1427](#) [636-3427](#) [636-4007](#) [641938-9](#) [641991-4](#) [644827-2](#) [65817-010LF](#)  
[65817-015LF](#) [65863-015LF](#) [66207-023LF](#) [67095-007LF](#) [67601157](#) [68648-049](#) [70.362.1628.0](#) [70-4210](#) [70-4226B](#) [70-4853B](#) [707-5020](#) [707-5028](#) [71.350.2428.0](#) [71918-208LF](#) [71961-016LF](#) [733-134](#) [733-162](#) [754199-000](#) [760-3052](#) [787-8014-00](#) [79531-3000](#) [FCN-360C032-B](#) [FCN-367T-T012/H](#) [FCN-723D010/2](#) [80.063.4001.1](#) [800-90-001-10-001000](#) [800-90-010-10-002000](#) [801-43-002-10-013000](#) [801-43-006-10-002000](#)