

Customer Information Sheet

DRAWING No.: M300-2240696F2

IF IN DOUBT - ASK

©

NOT TO SCALE

THIRD ANGLE PROJECTION

ALL DIMENSIONS IN mm

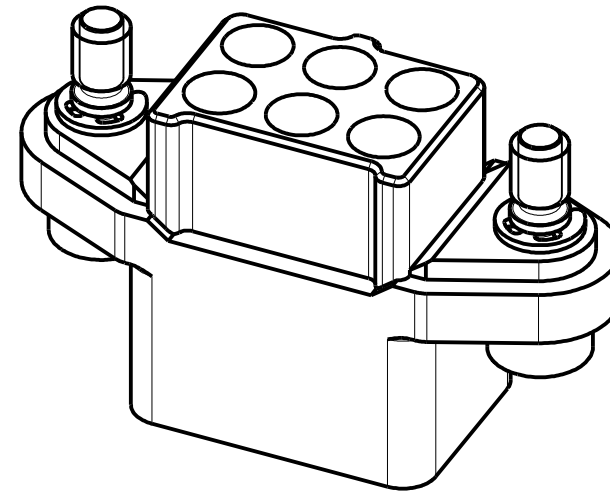
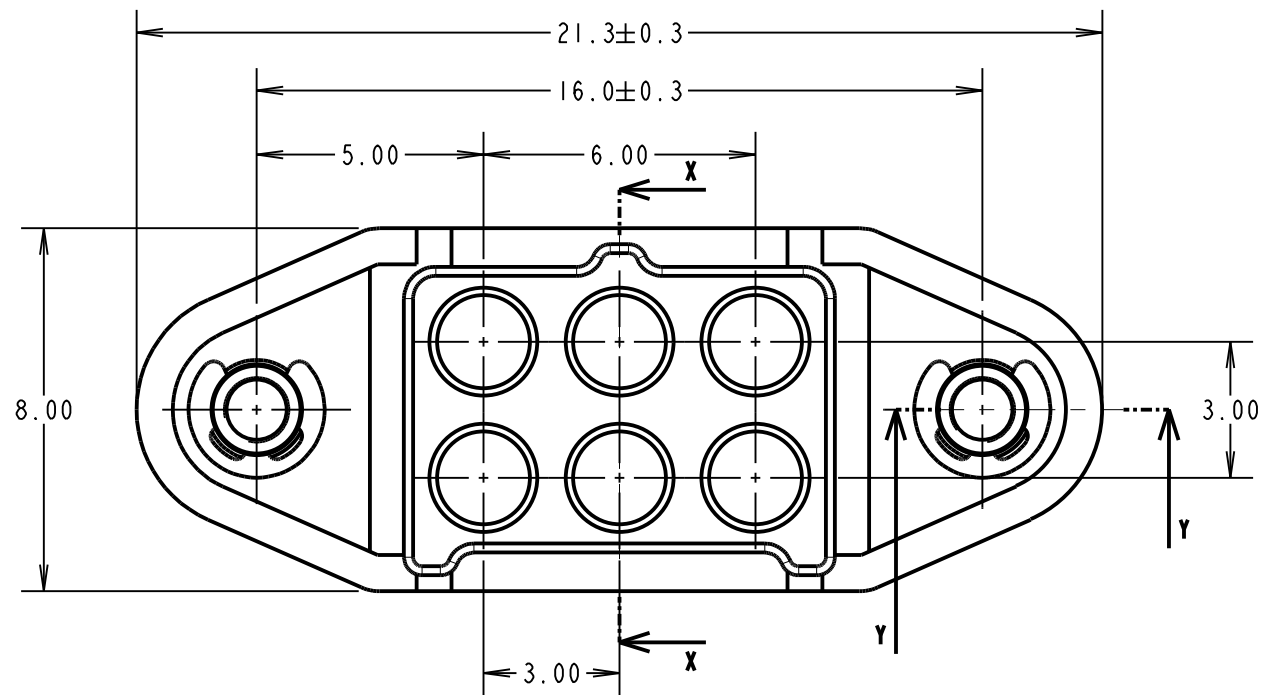

SPECIFICATIONS:

MATERIAL:
 MOULDING = GLASS-FILLED PA46 UL94V-0, GREEN
 CONTACT CLIP = BERYLLIUM COPPER
 CONTACT SHELL = BRASS
 JACKSCREW, CIRCLIP = STAINLESS STEEL
FINISH (ALL OVER NICKEL):
 0.10/0.17µ GOLD CLIP, 0.25/0.30µ GOLD SHELL
ELECTRICAL:
CURRENT RATING:
 5A MAX WITH 22 AWG M300-0020045 CONTACTS
 10A MAX WITH 18 AWG M300-0010045 CONTACTS
 WORKING VOLTAGE = 600V AC/DC
 VOLTAGE PROOF = 1800V AC/DC
 CONTACT RESISTANCE = 6mΩ MAX
 INSULATION RESISTANCE = 100MΩ MIN
MECHANICAL:
 DURABILITY = 1000 OPERATIONS
 INSERTION FORCE (∅1.0mm GAUGE) = 9.0N MAX
 WITHDRAWAL FORCE (∅1.0mm GAUGE) = 1.0N MIN
ENVIRONMENTAL:
 TEMPERATURE RANGE = -65°C TO +175°C
PACKING:
 BAG
 FOR COMPLETE SPECIFICATION, SEE COMPONENT SPECIFICATION C048XX (LATEST ISSUE)

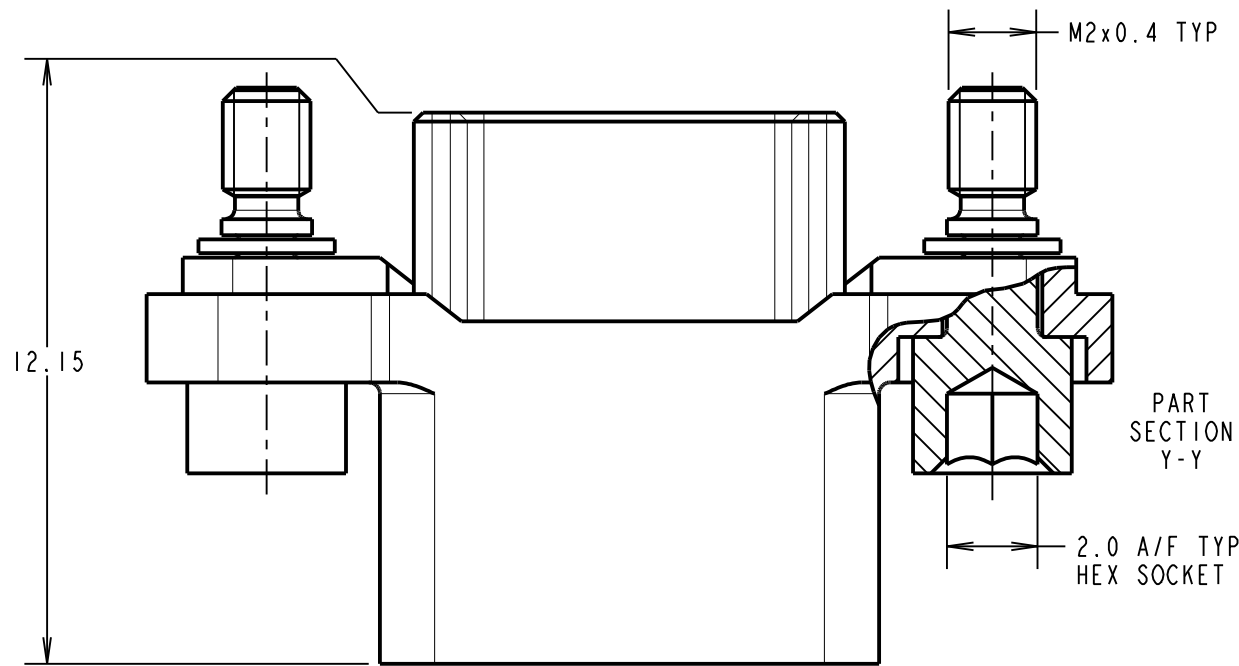

SECTION X-X

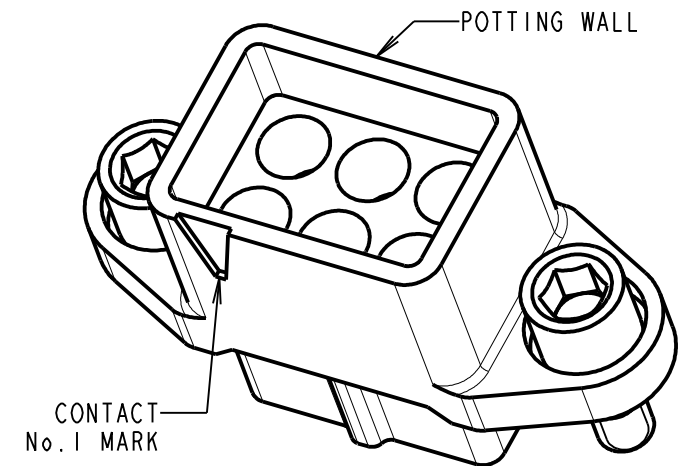
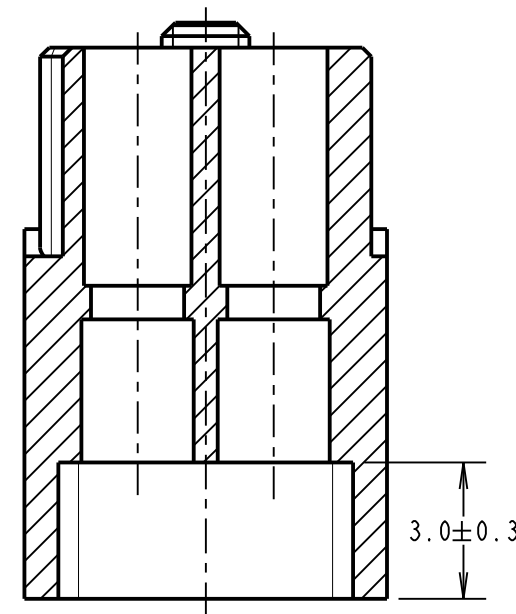

- NOTES:**
- FOR USE WITH M300-0010045 & M300-0020045 CONTACTS (NOT INCLUDED). M300-0010045 CONTACTS ARE SUITABLE FOR WIRE GAUGE 18 & 20 AWG. MAXIMUM INSULATION DIAMETER ∅1.80mm. M300-0020045 CONTACTS ARE SUITABLE FOR WIRE GAUGE 22 AWG. MAXIMUM INSULATION DIAMETER ∅1.40mm. BS3G210 TYPE A WIRE RECOMMENDED.
 - RECOMMENDED CRIMP TOOL = M22520/2-01, POSITIONER = Z80-058.
 - FOR INSTRUCTIONS ON HAND CRIMP TOOL M22520/2-01, SEE INSTRUCTION SHEET IS-01. STRIP WIRE BY 2.00mm FOR CRIMPING.
 - RECOMMENDED MATING PIN SIZE = ∅1.05-0.90mm.

MSP	2	28.07.15	13022
NAME	ISS.	DATE	C/NOTE
APPROVED: M.PERREN			
CHECKED: M.PLESTED			
DRAWN: MARK G PLESTED			
CUSTOMER REF.:			
ASSEMBLY DRG:			

HARWIN

www.harwin.com
 technical@harwin.com

THIS DRAWING AND ANY INFORMATION OR DESCRIPTIVE MATTER SET OUT HEREON ARE CONFIDENTIAL AND COPYRIGHT PROPERTY OF THE HARWIN GROUP AND MUST NOT BE DISCLOSED, LOANED, COPIED OR USED FOR MANUFACTURING, TENDERING OR FOR ANY OTHER PURPOSE WITHOUT THEIR WRITTEN PERMISSION.

TOLERANCES
 X. = ±1mm
 X.X = ±0.50mm
 X.XX = ±0.10mm
 X.XXX = ±0.01mm
 ANGLES = ±5°
 UNLESS STATED

MATERIAL:
 SEE ABOVE
FINISH: SEE ABOVE
S/AREA: mm²

TITLE: 1mm POWER CONNECTOR
 DIL CRIMP HOUSING WITH
 POTTING WALL FEMALE ASSEMBLY
DRAWING NUMBER:
M300-2240696F2
 SHT 2 OF 2

X-ON Electronics

Largest Supplier of Electrical and Electronic Components

Click to view similar products for [Headers & Wire Housings](#) category:

Click to view products by [Harwin](#) manufacturer:

Other Similar products are found below :

[892-18-020-10-001101](#) [58102-G61-06LF](#) [582553-1](#) [0009485154](#) [009176003701906](#) [0050291907](#) [LY20-4P-DT1-P1E-BR](#) [02.125.8002.8](#)
[609-3404](#) [61062-3](#) [622-0430](#) [622-3653LF](#) [63453-116](#) [636-1030](#) [636-1427](#) [636-3427](#) [636-4007](#) [641938-9](#) [641991-4](#) [644827-2](#) [65817-010LF](#)
[65817-015LF](#) [65863-015LF](#) [66207-023LF](#) [67095-007LF](#) [67601157](#) [68648-049](#) [70.362.1628.0](#) [70-4210](#) [70-4226B](#) [70-4853B](#) [707-5020](#) [707-5028](#) [71.350.2428.0](#) [71918-208LF](#) [71961-016LF](#) [733-134](#) [733-162](#) [754199-000](#) [760-3052](#) [787-8014-00](#) [79531-3000](#) [FCN-360C032-B](#) [FCN-367T-T012/H](#) [FCN-723D010/2](#) [80.063.4001.1](#) [800-90-001-10-001000](#) [800-90-010-10-002000](#) [801-43-002-10-013000](#) [801-43-006-10-002000](#)