

Customer Information Sheet

DRAWING No.: M40-620XX46R

SHEET 3 OF 4

IF IN DOUBT - ASK

©

NOT TO SCALE

THIRD ANGLE PROJECTION

ALL DIMENSIONS IN mm

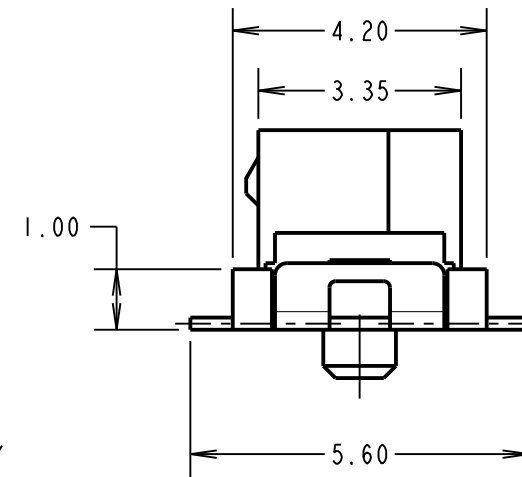
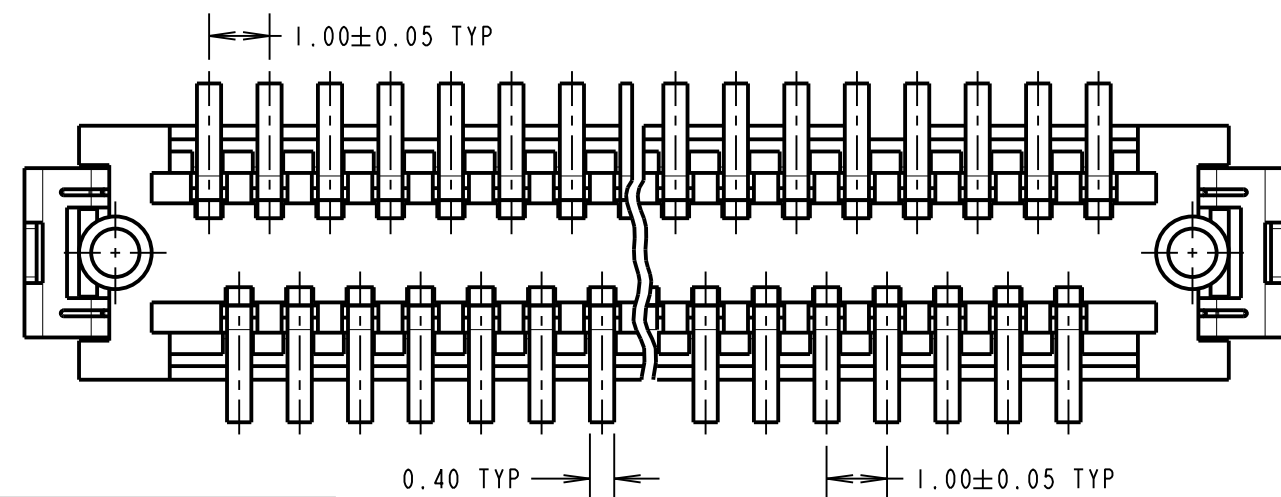
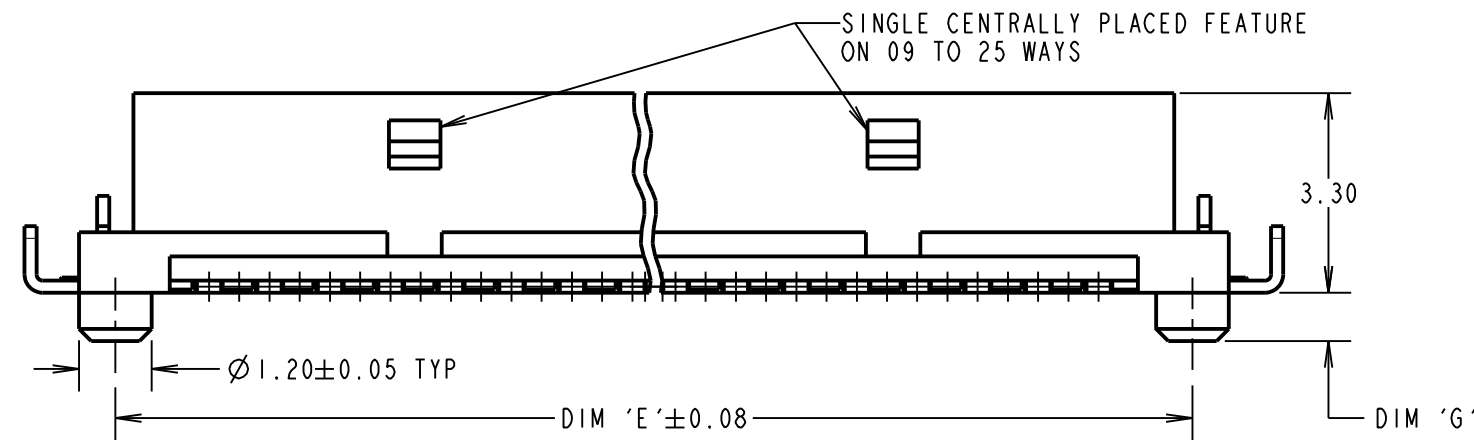
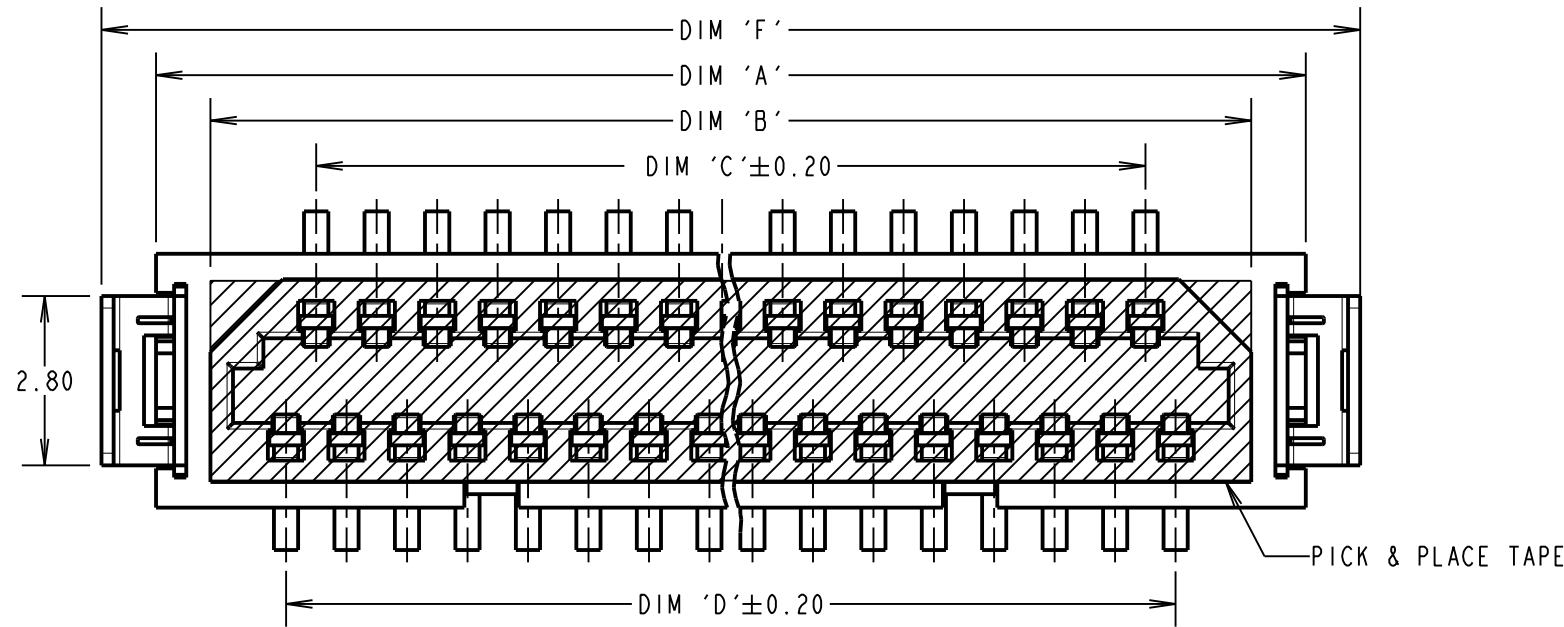

PART No.	No. OF CONTACTS	DIM 'A'	DIM 'B'	DIM 'C'	DIM 'D'	DIM 'E'	DIM 'F'	DIM 'G'	DIM 'H'
M40-6200946	9	8.30	6.50	3.00	4.00	7.10	10.10	1.00	1.84 +0.10 -0.00
M40-6201546	15	11.30	9.50	6.00	7.00	10.10	13.10		
M40-6202146	21	14.30	12.50	9.00	10.00	13.10	16.10		
M40-6202546	25	16.30	14.50	11.00	12.00	15.10	18.10	0.80	3.00 +0.00 -0.10
M40-6203146	31	19.30	17.50	14.00	15.00	18.10	21.10		
M40-6204146	41	24.30	22.50	19.00	20.00	23.10	26.10		
M40-6205146	51	29.30	27.50	24.00	25.00	28.10	31.10		

SPECIFICATIONS:

MATERIAL:

MOULDING = LCP, NATURAL, UL94V-0

CONTACTS = PHOSPHOR BRONZE

RETAINER = BRASS

FINISH = 2.03µ MIN 100% TIN, OVER 1.27µ MIN NICKEL

ELECTRICAL:

CURRENT RATING = 0.5 A

VOLTAGE RATING = 250V AC

DIELECTRIC STRENGTH = 250V AC FOR 1 MINUTE

INSULATION RESISTANCE = 500 MEGAOHMS MIN (100V DC)

CONTACT RESISTANCE = 50 MILLIOHMS MAX (0.1A DC)

MECHANICAL:

DURABILITY = 30 CYCLES MIN

ENVIRONMENTAL:

TEMPERATURE RANGE = -20°C TO +125°C

RECOMMENDED PAD LAYOUT

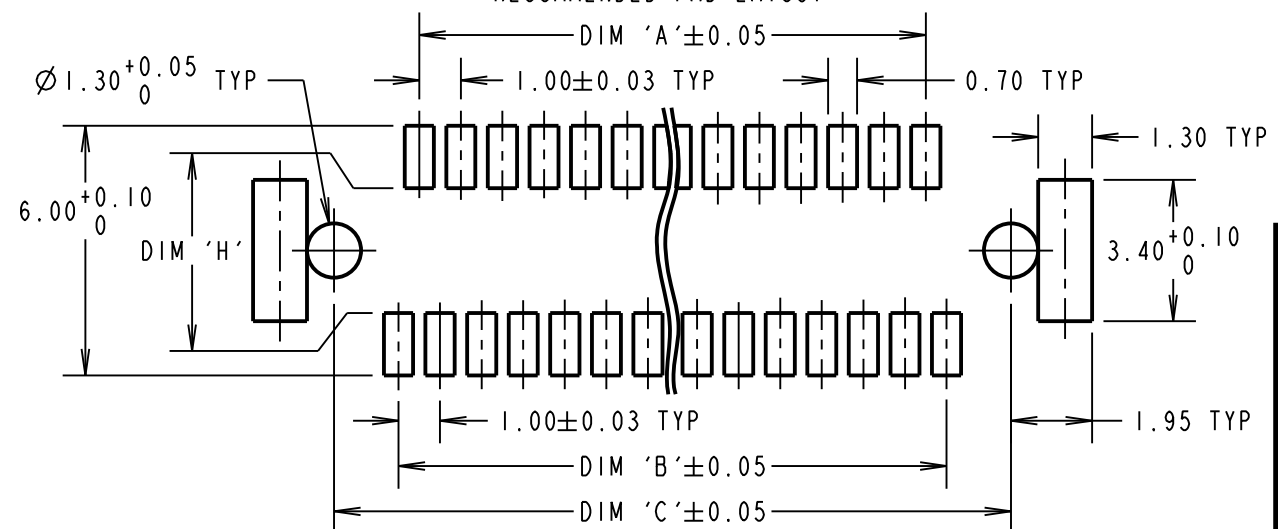

ORDER CODE: **M40-620XX46R**

No. OF CONTACTS: 9, 15, 21, 25, 31, 41, 51

FINISH: 46 = 100% TIN

NOTES:

- MATES WITH M40-600XX46 TO GIVE 4.3mm BOARD TO BOARD HEIGHT.
- ALL TOLERANCES ARE ±0.25 UNLESS OTHERWISE STATED.
- SEE DRAWING M40-620XX46 FOR COMPONENT DETAILS.
- SEE SHEET 4 FOR TAPE & REEL PRODUCT.
- SUPPLIED WITH HIGH TEMPERATURE TAPE FOR PICK & PLACE.

HARWIN

www.harwin.com
technical@harwin.com

THIS DRAWING AND ANY INFORMATION OR DESCRIPTIVE MATTER SET OUT HEREON ARE CONFIDENTIAL AND COPYRIGHT PROPERTY OF THE HARWIN GROUP AND MUST NOT BE DISCLOSED, LOANED, COPIED OR USED FOR MANUFACTURING, TENDERING OR FOR ANY OTHER PURPOSE WITHOUT THEIR WRITTEN PERMISSION.

TOLERANCES
X = ±1mm
X.X = ±0.50mm
X.XX = ±0.10mm
X.XXX = ±0.01mm
ANGLES = ±5°
UNLESS STATED

MATERIAL:

SEE ABOVE

FINISH: SEE ABOVE

S/AREA: mm²

TITLE: 1.00mm PITCH SMT SOCKET CONNECTOR (WITH PICK & PLACE, TAPE & REELED)

DRAWING NUMBER:

M40-620XX46R

SB	13	30.08.16	13452
NAME	ISS.	DATE	C/NOTE
APPROVED:		S.BENNETT	
CHECKED:		M.PLESTED	
DRAWN:		R.ADDE	
CUSTOMER REF.:			
ASSEMBLY DRG:			

SHT 3 OF 4

Customer Information Sheet

DRAWING No.: M40-620XX46R

SHEET 4 OF 4

IF IN DOUBT - ASK

©

NOT TO SCALE

THIRD ANGLE PROJECTION

ALL DIMENSIONS IN mm

ASSEMBLY PART No.	DIM 'A'	DIM 'B'	DIM 'C'	DIM 'D'	DIM 'E'	DIM 'F'	DIM 'G'
M40-6000946R	4.00	5.50	10.50	11.50		24.00±0.30	4.85
M40-6001546R	7.00	8.50	13.50				
M40-6002146R	10.00	11.50	16.50	14.20	28.40	32.00±0.30	
M40-6002546R	12.00	13.50	18.50				
M40-6003146R	15.00	16.50	21.50	20.20±0.15	40.40	44.00±0.30	
M40-6004146R	20.00	21.50	26.50				
M40-6005146R	25.00	26.50	31.50				4.65

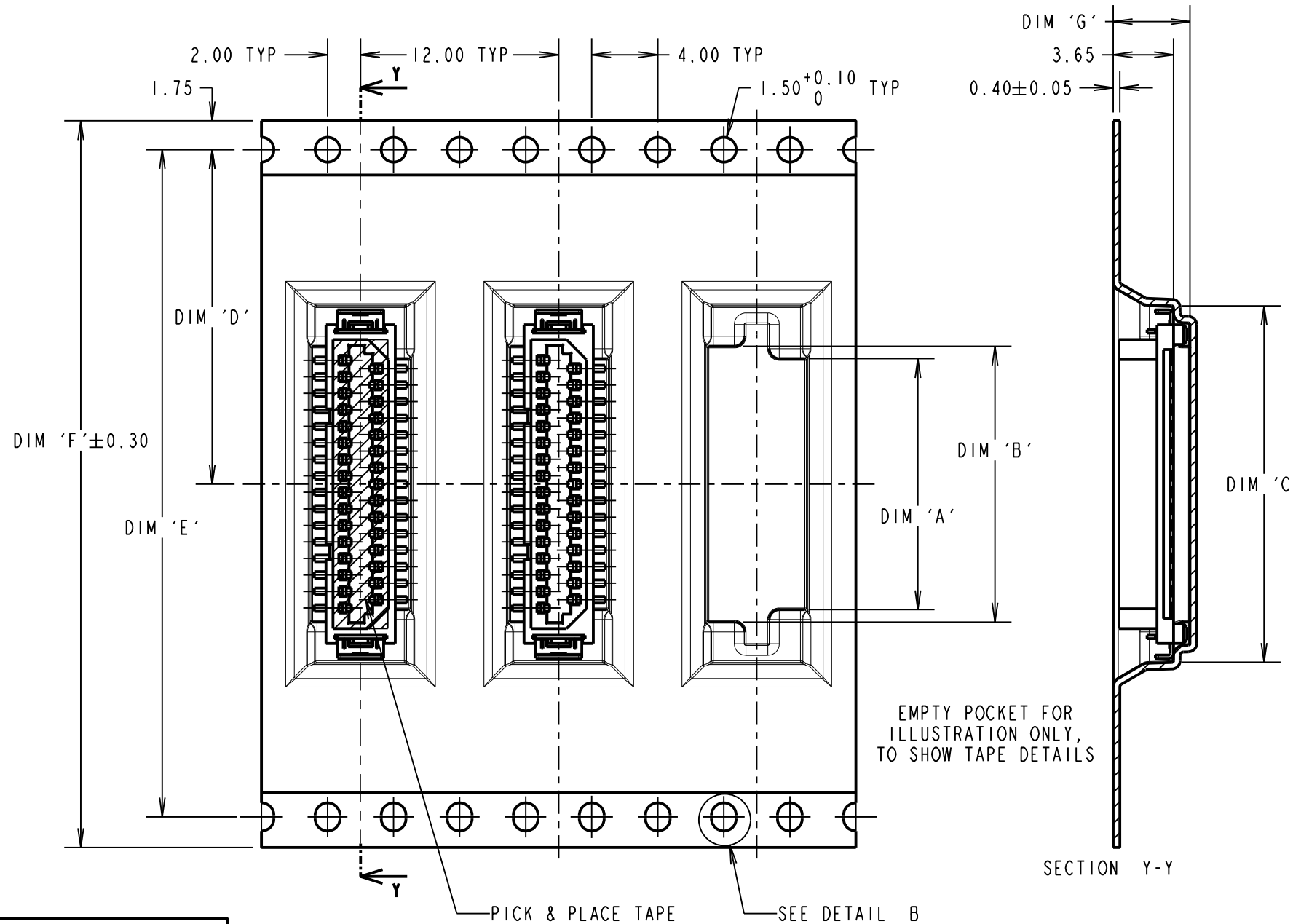
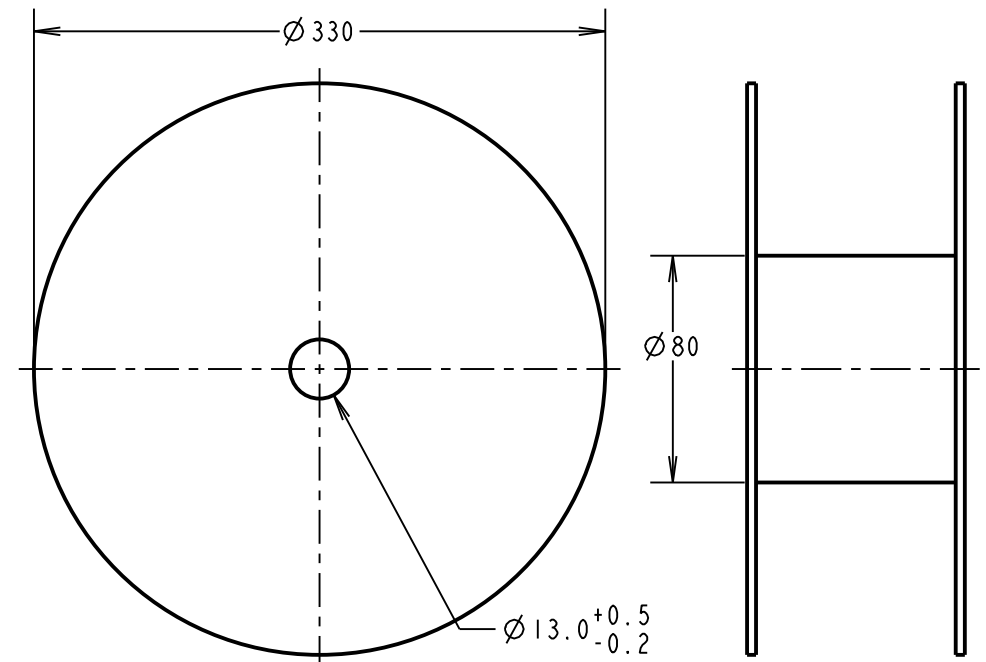
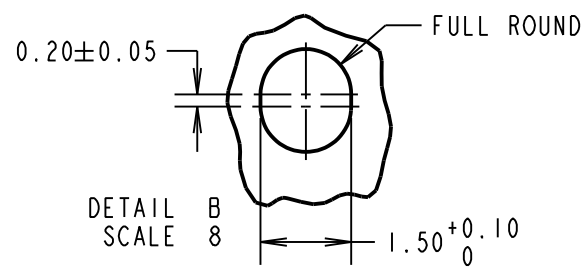

- NOTES:
- FOR CONNECTOR DIMENSIONS SEE SHEET 3.
 - TAPE AND REELING IN ACCORDANCE WITH ELECTRONIC INDUSTRIES ASSOCIATION EIA-481.
 - QUANTITY PER REEL = 1000 COMPONENTS.

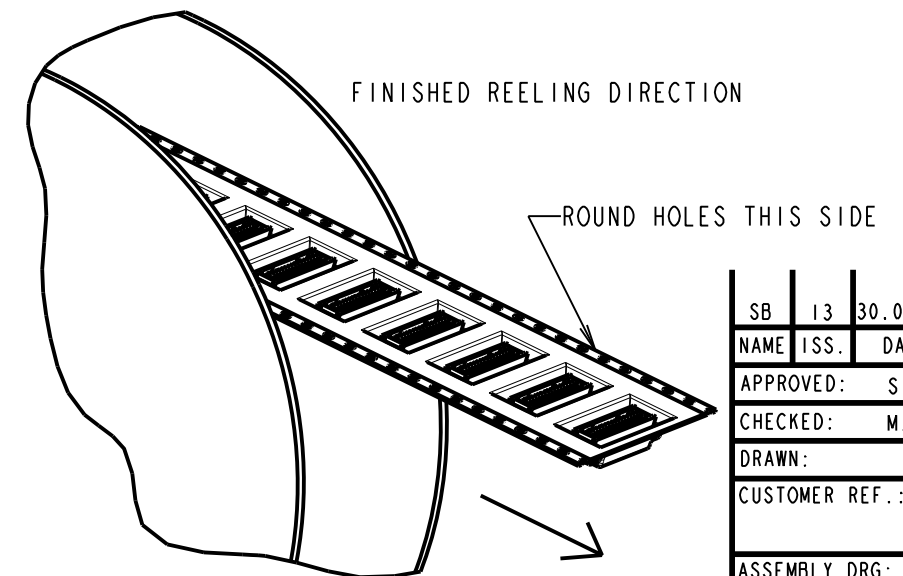

SB	13	30.08.16	13452
NAME	ISS.	DATE	C/NOTE
APPROVED:		S.BENNETT	
CHECKED:		M.PLESTED	
DRAWN:		R.ADDE	
CUSTOMER REF.:			
ASSEMBLY DRG:			

ORDER CODE: **M40-620XX46R**

No. OF CONTACTS: _____
 9, 15, 21, 25, 31, 41, 51

FINISH: _____
 46 = 100% TIN

HARWIN

www.harwin.com
 technical@harwin.com

THIS DRAWING AND ANY INFORMATION OR DESCRIPTIVE MATTER SET OUT HEREON ARE CONFIDENTIAL AND COPYRIGHT PROPERTY OF THE HARWIN GROUP AND MUST NOT BE DISCLOSED, LOANED, COPIED OR USED FOR MANUFACTURING, TENDERING OR FOR ANY OTHER PURPOSE WITHOUT THEIR WRITTEN PERMISSION.

TOLERANCES
 X. = ±1mm
 X.X = ±0.50mm
 X.XX = ±0.10mm
 X.XXX = ±0.01mm
 ANGLES = ±5°
 UNLESS STATED

MATERIAL: SEE ABOVE
 FINISH: SEE ABOVE
 S/AREA: mm²

TITLE: 1.00mm PITCH SMT SOCKET CONNECTOR (WITH PICK & PLACE, TAPE & REELED)
 DRAWING NUMBER: **M40-620XX46R**
 SHT 4 OF 4

X-ON Electronics

Largest Supplier of Electrical and Electronic Components

Click to view similar products for [Board to Board & Mezzanine Connectors](#) category:

Click to view products by [Harwin](#) manufacturer:

Other Similar products are found below :

[589158040000018](#) [MDF7C-18P-2.54DSA\(55\)](#) [FCN-230C068-11](#) [FCN-268F012-G/BD](#) [FCN-268F036-G/BD](#) [FCN-268M012-G/0D](#) [FCN-268M024-G/1D](#) [FCN-723J004/1](#) [MIS-048-01-F-D-DP-K](#) [832-10-034-10-001000](#) [FX4C-80S-1.27DSA](#) [FCN-214Q030-G/0](#) [FCN-234P048-G/0](#) [FCN-235D050-G/C](#) [210-93-314-41-105000](#) [2-22603-0](#) [MDF7-40DP-2.54DSA\(55\)](#) [AXG720047](#) [MIT-114-03-F-D-K](#) [55323-1519](#) [DF33-2P-3.3DSA\(24\)](#) [YFT-20-05-H-03-SB-K](#) [503308-3040](#) [026-6203-PDB](#) [027-6203-PDB](#) [069159702701000](#) [10123981-102LF](#) [101A10019X](#) [55650-0588-C](#) [68682-310LF](#) [68684-306](#) [75140-7012](#) [87471-650](#) [YTW-30-07-H-Q-410-140](#) [FCN-268F024-G0D](#) [10124054-515LF](#) [68685-603](#) [8-1616154-3](#) [MIS-019-01-F-D](#) [FCN-268M024-G/3D](#) [FCN-268M036-G/BD](#) [20021832-06016C1LF](#) [KX15-20KLDL-E1000E](#) [AXE810124](#) [FCN-214J100-G/0](#) [FCN-230C068-E/S](#) [AXE812124](#) [AXE816124](#) [AXE720127](#) [354184](#)