

Customer Information Sheet

DRAWING No.: M80-807XXX

SHEET 2 OF 2

IF IN DOUBT - ASK

©

NOT TO SCALE

THIRD ANGLE PROJECTION

ALL DIMENSIONS IN mm

ORDER CODE:

M80-807XXX

TOTAL No. OF WAYS

02, 03, 04, 05, 06, 07

FINISH

05 - GOLD

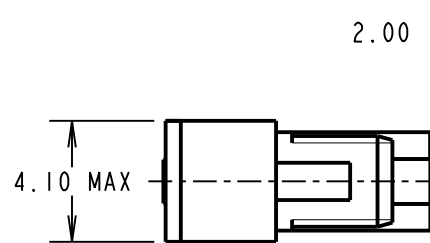

2.00 x No. OF PITCHES

2.00 TYP

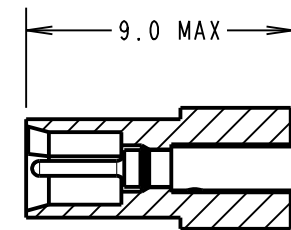
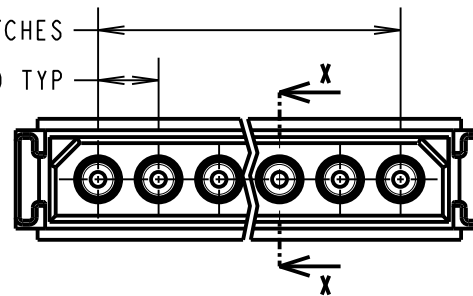

SECTION X-X

SPECIFICATIONS:

MATERIAL:

MOULDING = GLASS-FILLED
POLYAMIDE 46 UL94V-0, BLACK

CONTACTS = BRASS

FINISH:

CONTACTS:

05 = 0.25-0.30µ GOLD

ELECTRICAL:

CURRENT RATING AT 25°C = 3.0A MAX

CURRENT RATING AT 85°C = 2.2A MAX

WORKING VOLTAGE = 120V AC/DC

VOLTAGE PROOF = 360V AC/DC

CONTACT RESISTANCE (INITIAL) = 20 mΩ MAX

CONTACT RESISTANCE (AFTER CONDITIONING) = 25 mΩ MAX

INSULATION RESISTANCE (INITIAL) = 1,000 MΩ MIN

INSULATION RESISTANCE (AFTER CONDITIONING) = 100 MΩ MIN

MECHANICAL:

DURABILITY = 500 OPERATIONS

ENVIRONMENTAL:

TEMPERATURE RANGE = -55°C TO +125°C

PACKING:

BAG (CONTACTS AND MOULDINGS UN-ASSEMBLED)

FOR COMPLETE SPECIFICATION, SEE COMPONENT SPECIFICATION C005XX (LATEST ISSUE)

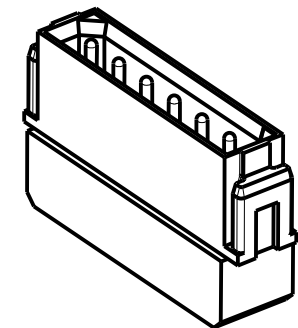
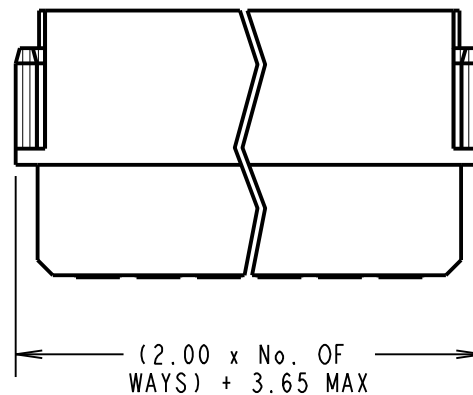

NOTES:

1. RECOMMENDED WIRE TYPE = BS3G210 TYPE A, PTFE INSULATED, 22 AWG. MAX INSULATION DIAMETER = Ø1.10mm, STRIP WIRE BY 2.00mm.
2. RECOMMENDED HAND CRIMP TOOL = M22520/2-01 WITH POSITIONER T5747. REFER TO TOOLING INSTRUCTION SHEET IS-01 FOR COMPLETE CRIMPING INSTRUCTIONS.
3. CONTACT INSERTION AND EXTRACTION TOOL = Z80-280. REFER TO TOOLING INSTRUCTION SHEET IS-25 FOR ASSEMBLY INSTRUCTIONS.
4. CONNECTORS ARE SUPPLIED WITH CONTACTS LOOSE.
5. FOR EXTRA CONTACTS USE PART NUMBER M80-040005.

MGP	3	29.07.11	11396
NAME	ISS.	DATE	C/NOTE
APPROVED: MGP			
CHECKED: RA			
DRAWN: W. J. BOURNE			
CUSTOMER REF.:			
ASSEMBLY DRG:			

HARWIN

THIS DRAWING AND ANY INFORMATION OR DESCRIPTIVE MATTER SET OUT HEREON ARE CONFIDENTIAL AND COPYRIGHT PROPERTY OF THE HARWIN GROUP AND MUST NOT BE DISCLOSED, LOANED, COPIED OR USED FOR MANUFACTURING, TENDERING OR FOR ANY OTHER PURPOSE WITHOUT THEIR WRITTEN PERMISSION.

TOLERANCES

X. = ±1mm
X.X = ±0.25mm
X.XX = ±0.10mm
X.XXX = ±0.01mm
ANGLES = ±5°
UNLESS STATED

MATERIAL:

SEE ABOVE

FINISH:

S/AREA:

mm²

TITLE:

DATAMATE 2mm PITCH
CRIMP SIL PLUG ASSEMBLY
LARGE BORE (22 AWG)

DRAWING NUMBER:

M80-807XXX

SHT

2 OF 2

HARWIN USA
TEL: 603 893 5376
FAX: 603 893 5396
mis@harwin.com

HARWIN Europe (UK)
TEL: 023 9231 4545
FAX: 023 9231 4590
mis@harwin.co.uk

HARWIN Asia
TEL: +65 6 779 4909
FAX: +65 6 779 3868
mis@harwin.com.sg

X-ON Electronics

Largest Supplier of Electrical and Electronic Components

Click to view similar products for [Headers & Wire Housings](#) category:

Click to view products by [Harwin](#) manufacturer:

Other Similar products are found below :

[892-18-020-10-001101](#) [58102-G61-06LF](#) [582553-1](#) [0009485154](#) [009176003701906](#) [0050291907](#) [LY20-4P-DT1-P1E-BR](#) [02.125.8002.8](#)
[609-3404](#) [61062-3](#) [622-0430](#) [622-3653LF](#) [63453-116](#) [636-1030](#) [636-1427](#) [636-3427](#) [636-4007](#) [641938-9](#) [641991-4](#) [644827-2](#) [65817-010LF](#)
[65817-015LF](#) [65863-015LF](#) [66207-023LF](#) [67095-007LF](#) [67601157](#) [68648-049](#) [70.362.1628.0](#) [70-4210](#) [70-4226B](#) [70-4853B](#) [707-5020](#) [707-](#)
[5028](#) [71.350.2428.0](#) [71918-208LF](#) [71961-016LF](#) [733-134](#) [733-162](#) [754199-000](#) [760-3052](#) [787-8014-00](#) [79531-3000](#) [FCN-360C032-B](#) [FCN-](#)
[367T-T012/H](#) [FCN-723D010/2](#) [80.063.4001.1](#) [800-90-001-10-001000](#) [800-90-010-10-002000](#) [801-43-002-10-013000](#) [801-43-006-10-002000](#)