

Customer Information Sheet

DRAWING No.: M80-808XXX

SHEET 2 OF 2

IF IN DOUBT - ASK

(C)

NOT TO SCALE

THIRD ANGLE PROJECTION

ALL DIMENSIONS IN mm

ORDER CODE:

M80-808XXX

TOTAL No. OF WAYS
02, 03, 04, 05, 06, 07

FINISH
05 - GOLD

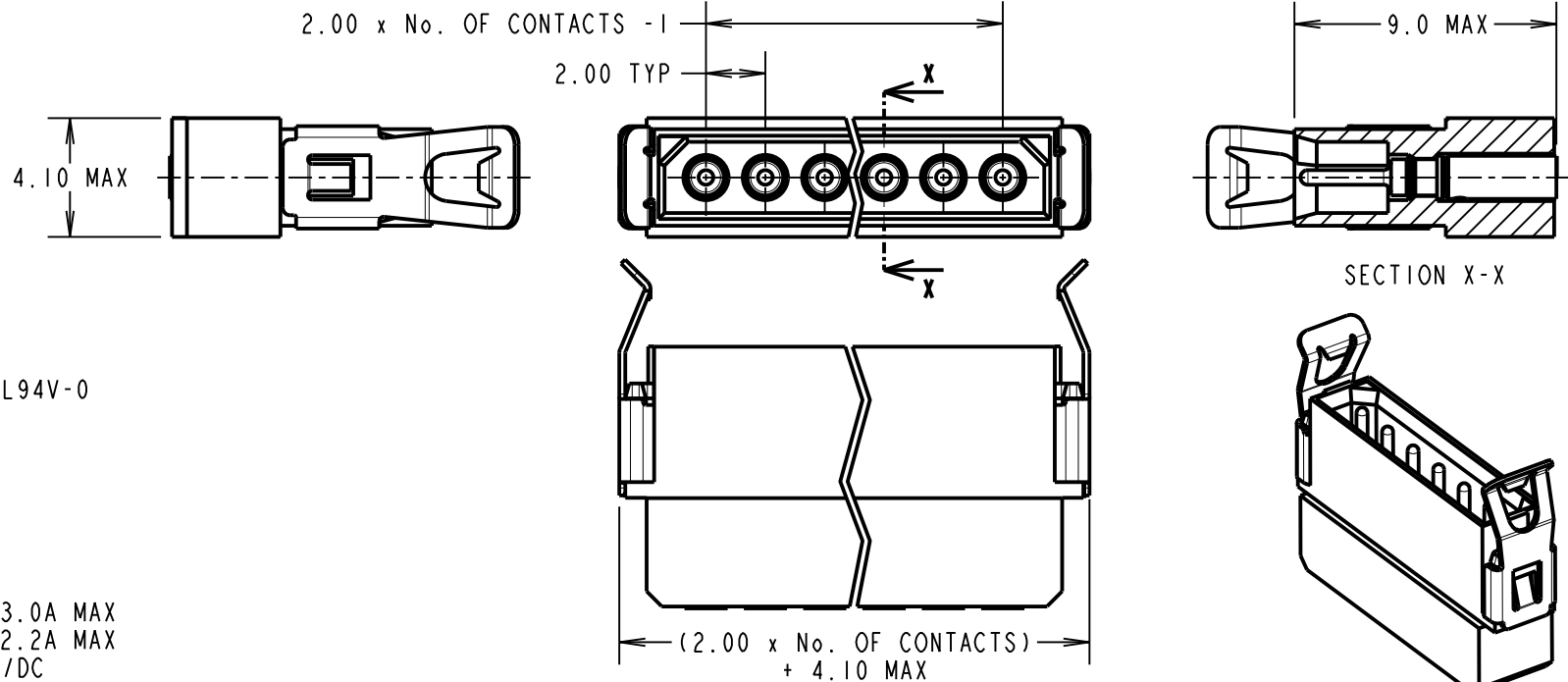

SPECIFICATIONS:

- MATERIAL:**
 MOULDING = GLASS-FILLED POLYAMIDE 46 UL94V-0
 CONTACTS = BRASS
 LATCH = BERYLLIUM COPPER
- FINISH:**
 CONTACTS:
 05 = 0.25-0.30µ GOLD
 LATCH = 1.25µ NICKEL
- ELECTRICAL:**
 CURRENT RATING AT 25°C = 3.0A MAX
 CURRENT RATING AT 85°C = 2.2A MAX
 WORKING VOLTAGE = 800V AC/DC
 VOLTAGE PROOF = 1200V AC/DC
 CONTACT RESISTANCE (INITIAL) = 20mΩ MAX
 CONTACT RESISTANCE (AFTER CONDITIONING) = 25mΩ MAX
 INSULATION RESISTANCE (INITIAL) = 1,000MΩ MIN
 INSULATION RESISTANCE (AFTER CONDITIONING) = 100MΩ MIN
- MECHANICAL:**
 DURABILITY = 500 OPERATIONS
- ENVIRONMENTAL:**
 TEMPERATURE RANGE = -55°C TO +125°C
- PACKING:**
 BAG (CONTACTS AND MOULDINGS UN-ASSEMBLED)
 FOR COMPLETE SPECIFICATION, SEE COMPONENT SPECIFICATION C005XX (LATEST ISSUE)

NOTES:

1. RECOMMENDED WIRE TYPE = BS3G210 TYPE A, PTFE INSULATED, 24-28 AWG. MAX INSULATION DIAMETER = Ø1.10mm, STRIP WIRE BY 2.00mm.
2. RECOMMENDED HAND CRIMP TOOL = M22520/2-01 WITH POSITIONER T5747. REFER TO TOOLING INSTRUCTION SHEET IS-01 FOR COMPLETE CRIMPING INSTRUCTIONS.
3. CONTACT INSERTION AND EXTRACTION TOOL = Z80-280. REFER TO TOOLING INSTRUCTION SHEET IS-25 FOR ASSEMBLY INSTRUCTIONS.
4. CONNECTORS ARE SUPPLIED WITH CONTACTS LOOSE.
5. FOR EXTRA CONTACTS USE PART NUMBER M80-0410005.

MSP	4	18.01.17	20097
NAME	ISS.	DATE	C/NOTE
APPROVED:		M.PERREN	
CHECKED:		M.PLESTED	
DRAWN:		W. J. BOURNE	
CUSTOMER REF.:			
ASSEMBLY DRG:			

HARWIN

www.harwin.com
technical@harwin.com

THIS DRAWING AND ANY INFORMATION OR DESCRIPTIVE MATTER SET OUT HEREON ARE CONFIDENTIAL AND COPYRIGHT PROPERTY OF THE HARWIN GROUP AND MUST NOT BE DISCLOSED, LOANED, COPIED OR USED FOR MANUFACTURING, TENDERING OR FOR ANY OTHER PURPOSE WITHOUT THEIR WRITTEN PERMISSION.

TOLERANCES
 X. = ±1mm
 X.X = ±0.50mm
 X.XX = ±0.10mm
 X.XXX = ±0.01mm
 ANGLES = ±5°
 UNLESS STATED

MATERIAL:
SEE ABOVE

FINISH:

S/AREA: mm²

TITLE: DATAMATE 2mm PITCH
CRIMP SIL LATCH PLUG ASSY
SMALL BORE (24-28 AWG)

DRAWING NUMBER: M80-808XXX

SHT 2 OF 2

X-ON Electronics

Largest Supplier of Electrical and Electronic Components

Click to view similar products for [Headers & Wire Housings](#) category:

Click to view products by [Harwin](#) manufacturer:

Other Similar products are found below :

[892-18-020-10-001101](#) [58102-G61-06LF](#) [582553-1](#) [0009485154](#) [009176003701906](#) [0050291907](#) [LY20-4P-DT1-P1E-BR](#) [02.125.8002.8](#)
[609-3404](#) [61062-3](#) [622-0430](#) [622-3653LF](#) [63453-116](#) [636-1030](#) [636-1427](#) [636-3427](#) [636-4007](#) [641938-9](#) [641991-4](#) [644827-2](#) [65817-010LF](#)
[65817-015LF](#) [65863-015LF](#) [66207-023LF](#) [67095-007LF](#) [67601157](#) [68648-049](#) [70.362.1628.0](#) [70-4210](#) [70-4226B](#) [70-4853B](#) [707-5020](#) [707-](#)
[5028](#) [71.350.2428.0](#) [71918-208LF](#) [71961-016LF](#) [733-134](#) [733-162](#) [754199-000](#) [760-3052](#) [787-8014-00](#) [79531-3000](#) [FCN-360C032-B](#) [FCN-](#)
[367T-T012/H](#) [FCN-723D010/2](#) [80.063.4001.1](#) [800-90-001-10-001000](#) [800-90-010-10-002000](#) [801-43-002-10-013000](#) [801-43-006-10-002000](#)