

Customer Information Sheet

DRAWING No.: M80-844XXXX

IF IN DOUBT - ASK

(C)

NOT TO SCALE

THIRD ANGLE PROJECTION

ALL DIMENSIONS IN mm

SPECIFICATIONS:

MATERIAL:
 Moulding = HIGH TEMP. POLYAMIDE 46,
 UL94V-0, BLACK
 CLIP = BERYLLIUM COPPER
 SHELL = COPPER ALLOY

FINISH:
 42 = 0.30µ GOLD CLIP, 4.0µ 100% TIN
 OVER NICKEL SHELL
 45 = 0.30µ GOLD CLIP, 0.28µ GOLD SHELL

ELECTRICAL:
 CURRENT RATING AT 25°C = 3.0A MAX
 CURRENT RATING AT 85°C = 2.2A MAX
 WORKING VOLTAGE = 800V AC/DC
 VOLTAGE PROOF = 1200V AC/DC
CONTACT RESISTANCE:
 INITIAL = 25mΩ MAX
 AFTER CONDITIONING = 20mΩ MAX
INSULATION RESISTANCE:
 INITIAL = 1000MΩ MIN
 AFTER CONDITIONING = 100MΩ MIN

ENVIRONMENTAL:
 TEMPERATURE RANGE = -55°C TO +125°C

MECHANICAL:
 DURABILITY = 500 OPERATIONS
 INSERTION FORCE = 2.8N MAX, 1.0N MIN
 WITHDRAWAL FORCE = 1.8N MAX, 0.2N MIN

PACKING:
 BAGS (CONNECTOR SUPPLIED UN-ASSEMBLED)
 FOR COMPLETE SPECIFICATION, SEE COMPONENT
 SPECIFICATION C005XX (LATEST ISSUE)

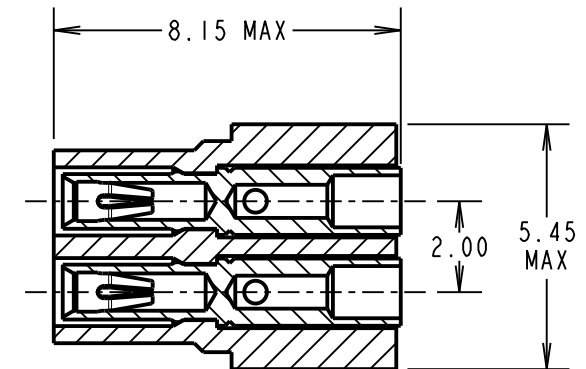
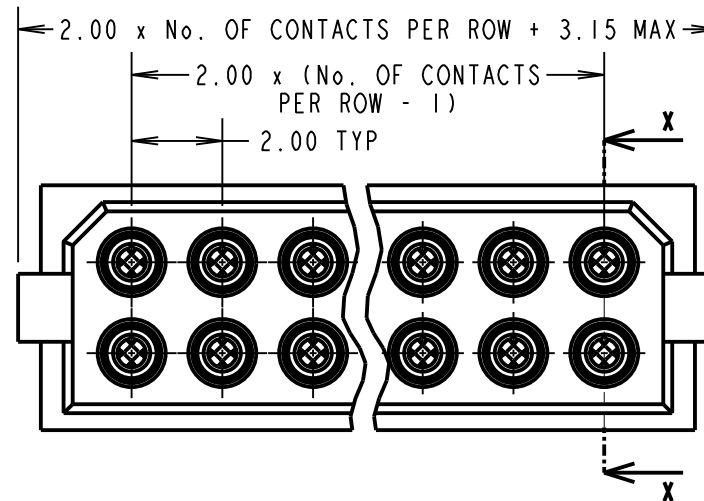

SECTION X-X

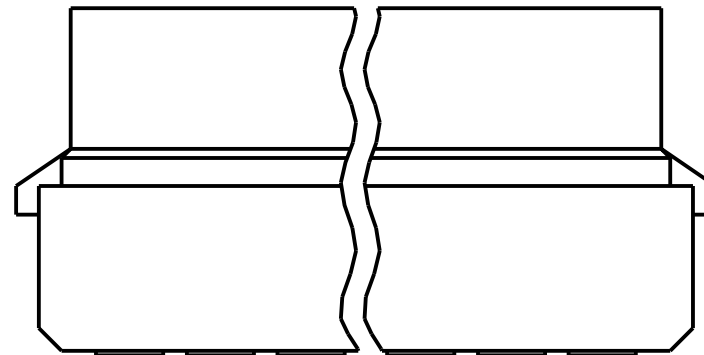

NOTES:

- RECOMMENDED WIRE TYPE = BS3G210 TYPE A, PTFE INSULATED 24 - 28AWG. MAX INSULATION DIAMETER = \varnothing 1.10mm. STRIP WIRE BY 2.00mm.
- RECOMMENDED HAND CRIMP TOOL = M22520/2-01 WITH POSITIONER T5747. SEE TOOLING INSTRUCTION SHEET IS-01 FOR COMPLETE CRIMPING INSTRUCTIONS.
- CONTACT INSERTION AND EXTRACTION TOOL = Z80-280. REFER TO INSTRUCTION SHEET IS-25 FOR ASSEMBLY INSTRUCTIONS.

ORDER CODE:

M80-844XXXX

TOTAL No. OF WAYS _____

04 - 20, 26, 34 (EVEN NUMBERS ONLY)

FINISH: _____

42 - GOLD CLIP, 100% TIN SHELL
 45 - GOLD CLIP, GOLD SHELL

SF	6	09.07.14	12526
NAME	ISS.	DATE	C/NOTE
APPROVED: S.FLOWER			
CHECKED: M.PLESTED			
DRAWN: I. SANDY			
CUSTOMER REF.:			
ASSEMBLY DRG:			

HARWIN

www.harwin.com
 technical@harwin.com

THIS DRAWING AND ANY INFORMATION OR DESCRIPTIVE MATTER SET OUT HEREON ARE CONFIDENTIAL AND COPYRIGHT PROPERTY OF THE HARWIN GROUP AND MUST NOT BE DISCLOSED, LOANED, COPIED OR USED FOR MANUFACTURING, TENDERING OR FOR ANY OTHER PURPOSE WITHOUT THEIR WRITTEN PERMISSION.

TOLERANCES
 X. = \pm 1mm
 X.X = \pm 0.25mm
 X.XX = \pm 0.10mm
 X.XXX = \pm 0.01mm
 ANGLES = \pm 5°
 UNLESS STATED

MATERIAL:

SEE ABOVE

FINISH: SEE ABOVE

S/AREA: mm²

TITLE:

DATAMATE CRIMP
 DIL SOCKET ASSEMBLY
 SMALL BORE (24 - 28 AWG)

DRAWING NUMBER:

M80-844XXXX

SHT

2 OF 2

X-ON Electronics

Largest Supplier of Electrical and Electronic Components

Click to view similar products for [Headers & Wire Housings](#) category:

Click to view products by [Harwin](#) manufacturer:

Other Similar products are found below :

[892-18-020-10-001101](#) [58102-G61-06LF](#) [582553-1](#) [0009485154](#) [009176003701906](#) [0050291907](#) [LY20-4P-DT1-P1E-BR](#) [02.125.8002.8](#)
[609-3404](#) [61062-3](#) [622-0430](#) [622-3653LF](#) [63453-116](#) [636-1030](#) [636-1427](#) [636-3427](#) [636-4007](#) [641938-9](#) [641991-4](#) [644827-2](#) [65817-010LF](#)
[65817-015LF](#) [65863-015LF](#) [66207-023LF](#) [67095-007LF](#) [67601157](#) [68648-049](#) [70.362.1628.0](#) [70-4210](#) [70-4226B](#) [70-4853B](#) [707-5020](#) [707-5028](#) [71.350.2428.0](#) [71918-208LF](#) [71961-016LF](#) [733-134](#) [733-162](#) [754199-000](#) [760-3052](#) [787-8014-00](#) [79531-3000](#) [FCN-360C032-B](#) [FCN-367T-T012/H](#) [FCN-723D010/2](#) [80.063.4001.1](#) [800-90-001-10-001000](#) [800-90-010-10-002000](#) [801-43-002-10-013000](#) [801-43-006-10-002000](#)