

Customer Information Sheet

DRAWING No.: M80-888XXXX

SHEET 2 OF 2

IF IN DOUBT - ASK

(C)

NOT TO SCALE

THIRD ANGLE PROJECTION

ALL DIMENSIONS IN mm

SPECIFICATION:

MATERIAL:

MOULDING = GLASS-FILLED PBT UL94V-0, BLACK

CLIP = BERYLLIUM COPPER

SHELL = COPPER ALLOY

FINISH (ALL OVER NICKEL):

CONTACTS:

01 = 0.30µ GOLD CLIP, 4.0µ 100% TIN SHELL

05 = 0.30µ GOLD CLIP, 0.28µ GOLD SHELL

ELECTRICAL:

CURRENT RATING AT 25°C = 3.0A MAX

CURRENT RATING AT 85°C = 2.2A MAX

WORKING VOLTAGE = 120V AC/DC

VOLTAGE PROOF = 360V AC/DC

CONTACT RESISTANCE:

INITIAL = 20mΩ MAX

AFTER CONDITIONING = 25mΩ MAX

INSULATION RESISTANCE:

INITIAL = 1000MΩ MIN

AFTER CONDITIONING = 100MΩ MIN

MECHANICAL:

DURABILITY = 500 OPERATIONS

INSERTION FORCE = 2.8N MAX, 1.0N MIN

WITHDRAWAL FORCE = 1.8N MAX, 0.2N MIN

ENVIRONMENTAL:

TEMPERATURE RANGE = -55°C TO +125°C

PACKING:

BAG (CONTACTS AND MOULDINGS UN-ASSEMBLED)

NOTES:

1. RECOMMENDED WIRE TYPE = BS3G210 TYPE A, PTFE INSULATED, 24-28 AWG. MAX INSULATION DIAMETER = Ø1.10mm, STRIP WIRE BY 2.00mm.
2. RECOMMENDED HAND CRIMP TOOL = M22520/2-01 WITH POSITIONER T5747. REFER TO INSTRUCTION SHEET IS-01 FOR COMPLETE CRIMPING INSTRUCTIONS.
3. CONTACT INSERTION AND EXTRACTION TOOL = Z80-280. REFER TO INSTRUCTION SHEET IS-25 FOR ASSEMBLY INSTRUCTIONS.

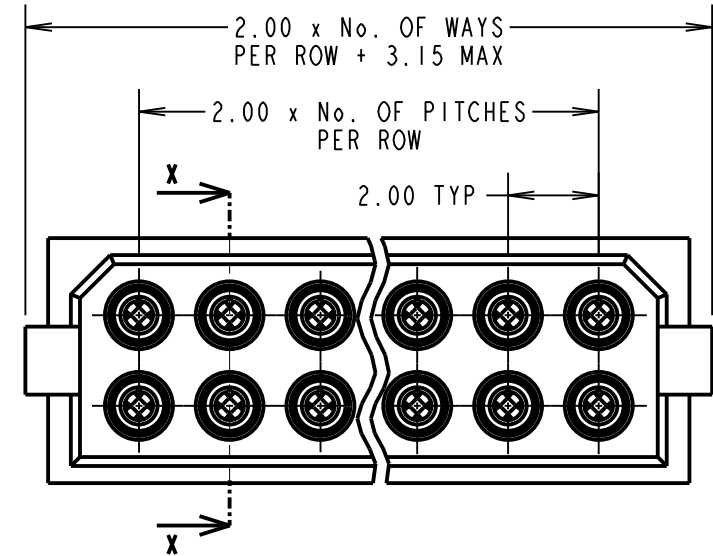
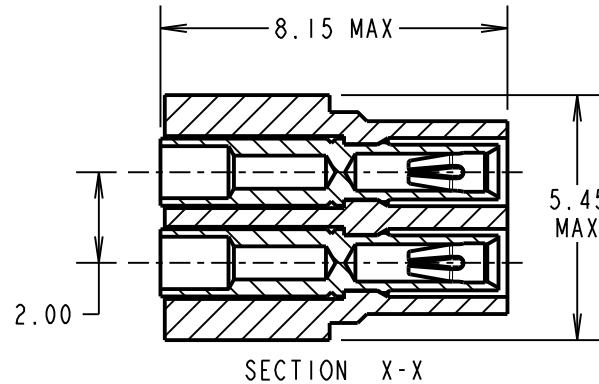

COMMERCIAL ORDER CODE:

M80-888XXXX

TOTAL No. OF WAYS
04 - 20, 26, 34

FINISH:
01 - GOLD CLIP, 100% TIN SHELL
05 - GOLD CLIP, GOLD SHELL

BRITISH STANDARD ORDER CODE: TO BS9525 F0033

B5740-2XX-F-C-X

TOTAL No. OF WAYS
04 - 20, 26, 34

FINISH:
0 - GOLD CLIP, 100% TIN SHELL
2 - GOLD CLIP, GOLD SHELL

SM	13	08.08.11	11389
NAME	ISS.	DATE	C/NOTE
APPROVED: S. MCCULLAGH			
CHECKED:		R. ADDE	
DRAWN:		W. J. BOURNE	
CUSTOMER REF.:			
ASSEMBLY DRG:			

HARWIN

THIS DRAWING AND ANY INFORMATION OR DESCRIPTIVE MATTER SET OUT HEREON ARE CONFIDENTIAL AND COPYRIGHT PROPERTY OF THE HARWIN GROUP AND MUST NOT BE DISCLOSED, LOANED, COPIED OR USED FOR MANUFACTURING, TENDERING OR FOR ANY OTHER PURPOSE WITHOUT THEIR WRITTEN PERMISSION.

TOLERANCES
X. = ±1mm
X.X = ±0.25mm
X.XX = ±0.10mm
X.XXX = ±0.01mm
ANGLES = ±5°
UNLESS STATED

MATERIAL:
SEE ABOVE

FINISH: SEE ABOVE

S/AREA: mm²

TITLE: DATAMATE 2mm PITCH CRIMP DIL SOCKET ASSY SMALL BORE (24-28 AWG)

DRAWING NUMBER:
M80-888XXXX

SHT 2 OF 2

HARWIN USA TEL: 603 893 5376 FAX: 603 893 5396 mis@harwin.com	HARWIN Europe (UK) TEL: 023 9231 4545 FAX: 023 9231 4590 mis@harwin.co.uk	HARWIN Asia TEL: +65 6 779 4909 FAX: +65 6 779 3868 mis@harwin.com.sg
---	---	---

X-ON Electronics

Largest Supplier of Electrical and Electronic Components

Click to view similar products for [Headers & Wire Housings](#) category:

Click to view products by [Harwin](#) manufacturer:

Other Similar products are found below :

[892-18-020-10-001101](#) [58102-G61-06LF](#) [582553-1](#) [0009485154](#) [009176003701906](#) [0050291907](#) [LY20-4P-DT1-P1E-BR](#) [02.125.8002.8](#)
[609-3404](#) [61062-3](#) [622-0430](#) [622-3653LF](#) [63453-116](#) [636-1030](#) [636-1427](#) [636-3427](#) [636-4007](#) [641938-9](#) [641991-4](#) [644827-2](#) [65817-010LF](#)
[65817-015LF](#) [65863-015LF](#) [66207-023LF](#) [67095-007LF](#) [67601157](#) [68648-049](#) [70.362.1628.0](#) [70-4210](#) [70-4226B](#) [70-4853B](#) [707-5020](#) [707-](#)
[5028](#) [71.350.2428.0](#) [71918-208LF](#) [71961-016LF](#) [733-134](#) [733-162](#) [754199-000](#) [760-3052](#) [787-8014-00](#) [79531-3000](#) [FCN-360C032-B](#) [FCN-](#)
[367T-T012/H](#) [FCN-723D010/2](#) [80.063.4001.1](#) [800-90-001-10-001000](#) [800-90-010-10-002000](#) [801-43-002-10-013000](#) [801-43-006-10-002000](#)