

# Customer Information Sheet

DRAWING No.: S8081-46R

SHEET 2 OF 2

IF IN DOUBT - ASK

©

NOT TO SCALE

THIRD ANGLE PROJECTION

ALL DIMENSIONS IN mm

**NOTES:**

1. THIS PRODUCT IS RECOMMENDED FOR USE WITH S07-46 AND S08-46 LED BRIDGE PINS.
2. ALL PRODUCT IS RoHS AND REACH COMPLIANT.
3. PRODUCT IS TAPE AND REELED IN GENERAL ACCORDANCE WITH EIA-481-2 (ELECTRONICS INDUSTRIES ASSOCIATION).
4. PACKAGING = 10,000 COMPONENTS PER REEL.
5. CURRENT RATING IS DEPENDANT ON USAGE. SEE TEST REPORT HT055XX (LATEST ISSUE) FOR MORE INFORMATION ON CURRENT RATING.

**SPECIFICATION:**

**MATERIAL:**  
CONTACT = STAINLESS STEEL, 0.10mm THICK

**FINISH:**  
1.0µ - 3.0µ TIN OVER 0.4µ - 1.5µ NICKEL  
CURRENT RATING = 3.0A - 13.0A  
(SEE NOTE 5)

VOLTAGE RATING = 250V AC/DC

**MECHANICAL:**  
INSERTION FORCE = 12N MAX (INITIAL)  
WITHDRAWAL FORCE = 4N MIN (INITIAL)  
DURABILITY = 10 CYCLES MAX

**ENVIRONMENTAL:**  
OPERATING TEMPERATURE = -40°C TO +85°C

**SOLDERING DATA:**  
SOLDERING HEAT RESISTANCE = 260°C FOR 10 SECONDS MAX

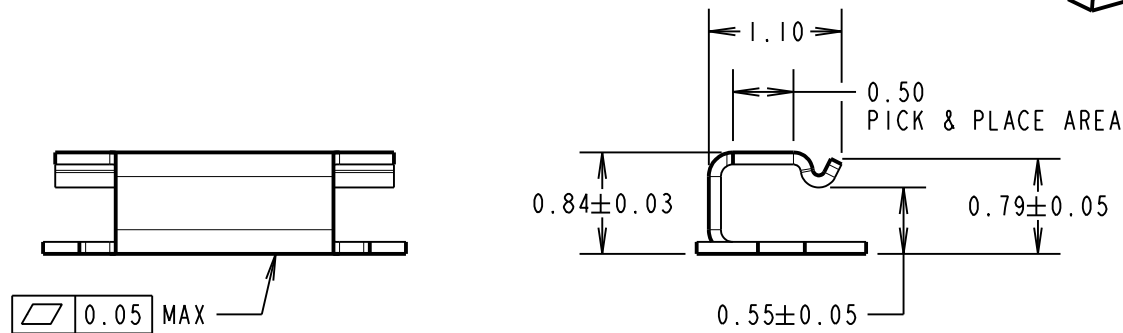
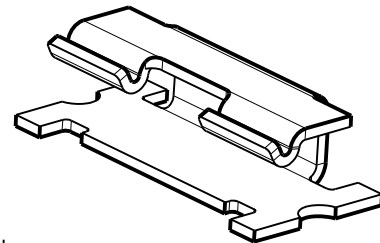
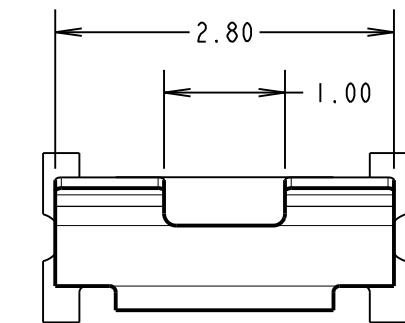
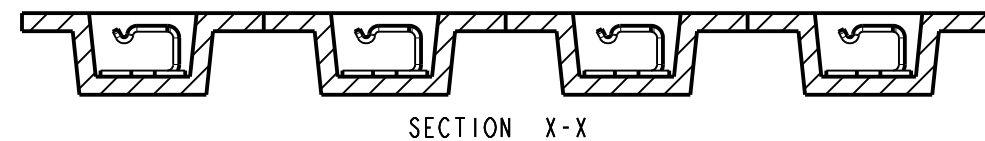
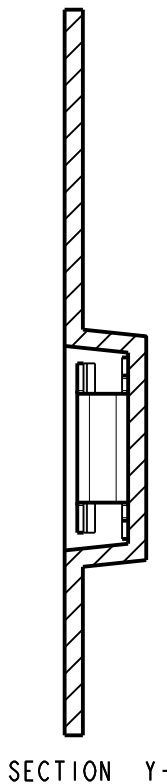
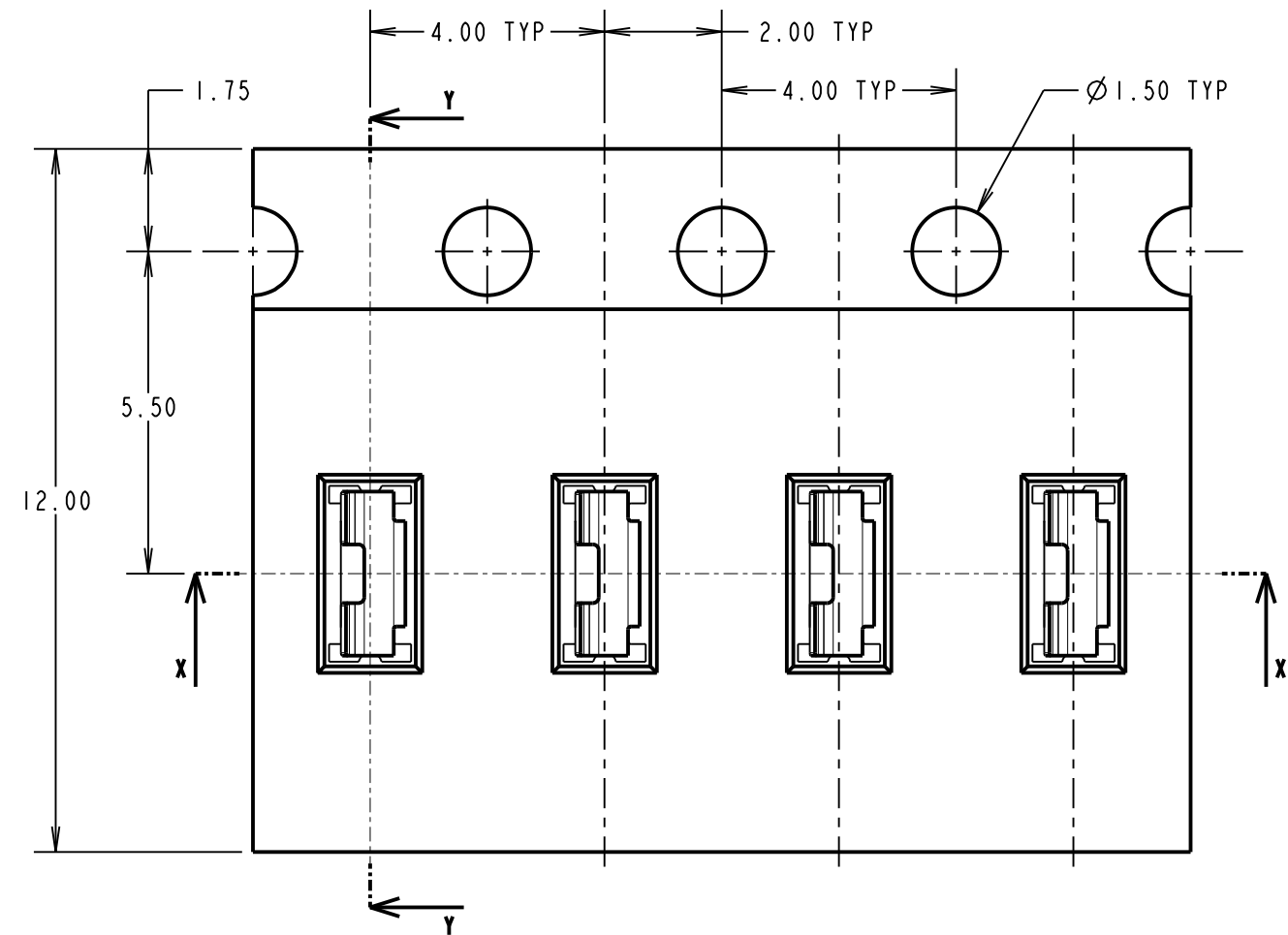
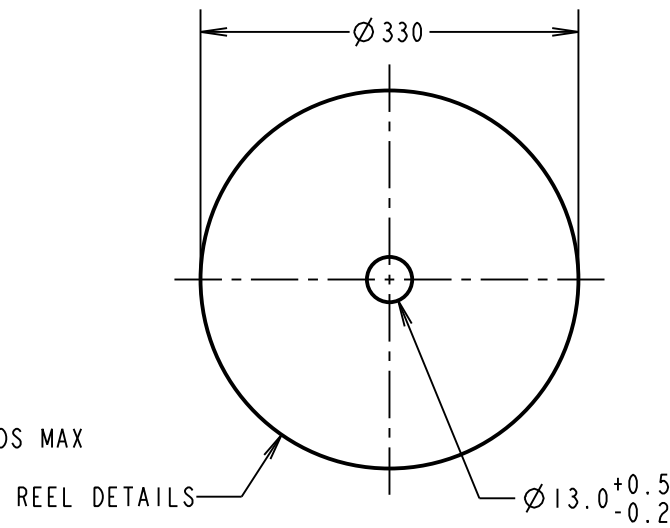

COMPONENT DETAILS

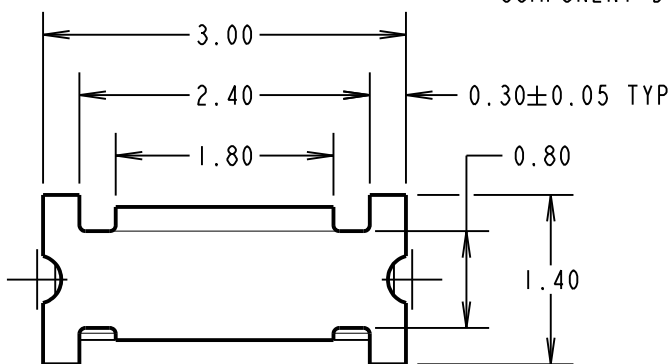
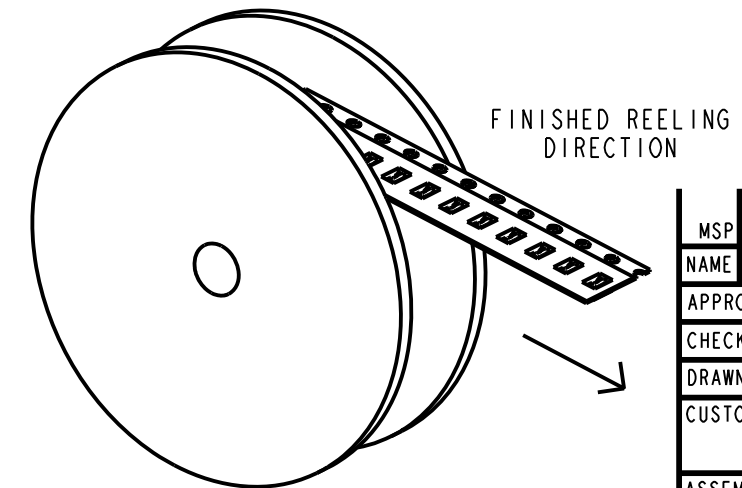
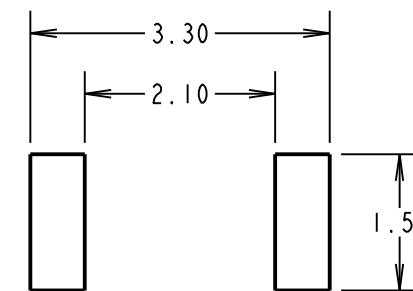

MSP	4	19.04.17	20428
NAME	ISS.	DATE	C/NOTE
APPROVED: M. PERREN			
CHECKED: S. BENNETT			
DRAWN: S. BENNETT			
CUSTOMER REF.:			
ASSEMBLY DRG:			

**HARWIN**

www.harwin.com  
technical@harwin.com

THIS DRAWING AND ANY INFORMATION OR DESCRIPTIVE MATTER SET OUT HEREON ARE CONFIDENTIAL AND COPYRIGHT PROPERTY OF THE HARWIN GROUP AND MUST NOT BE DISCLOSED, LOANED, COPIED OR USED FOR MANUFACTURING, TENDERING OR FOR ANY OTHER PURPOSE WITHOUT THEIR WRITTEN PERMISSION.

**TOLERANCES**  
X. = ±1mm  
X.X = ±0.25mm  
X.XX = ±0.10mm  
X.XXX = ±0.01mm  
ANGLES = ±5°  
UNLESS STATED

**MATERIAL:**  
SEE ABOVE

**FINISH:** SEE ABOVE  
**S/AREA:** mm<sup>2</sup>

**TITLE:** HORIZONTAL SMT CABLE AND PIN CLIP

**DRAWING NUMBER:** S8081-46R

SHT 2 OF 2

## X-ON Electronics

Largest Supplier of Electrical and Electronic Components

*Click to view similar products for [Circuit Board Hardware - PCB category](#):*

*Click to view products by [Harwin manufacturer](#):*

Other Similar products are found below :

[8919-0-00-15-00-00-03-0](#) [0135-0-15-01-30-27-04-0](#) [5970-1-15-01-32-14-04-0](#) [0149-0-15-15-30-27-04-0](#) [MBI 1 BLUE](#) [7305-0-15-15-47-14-10-0](#) [MLN 150/1 BLACK](#) [8579-0-15-80-11-27-10-0](#) [8579-1-15-15-11-27-10-0](#) [8830-0-15-01-22-14-10-0](#) [8836-0-00-21-00-00-03-0](#) [PRUEF 2 RED](#) [9976-0-00-00-00-00-03-0](#) [PW1616](#) [1215-3-05-00-00-00-01-0](#) [1231](#) [1303-0-15-15-47-14-04-0](#) [1404-3](#) [1404-4](#) [1406-4](#) [1407-3](#) [1406-3](#) [1407-4](#) [1408-3](#) [1424-4](#) [1427-3](#) [1419-4](#) [1426-4](#) [1548-103](#) [1938-0-00-00-00-00-03-0](#) [1942-0-00-00-00-00-03-0](#) [2101-3-00-44-00-00-07-0](#) [2108-2-00-50-00-00-07-0](#) [2109-2-00-44-00-00-07-0](#) [2110-2-00-44-00-00-07-0](#) [2111-2-00-00-00-00-07-0](#) [2113-4-00-44-00-00-07-0](#) [2301-3-00-44-00-00-07-0](#) [2308-1-00-50-00-00-07-0](#) [2313-2-00-00-00-00-07-0](#) [2315-2-01-44-00-00-07-0](#) [2333-1-00-50-00-00-07-0](#) [9000-0-00-00-00-00-03-0](#) [2506-2-00-50-00-00-07-0](#) [2507-2-01-44-00-00-07-0](#) [2508-2-00-44-00-00-07-0](#) [2561-2-00-44-00-00-07-0](#) [9220](#) [9234-0-15-15-30-14-10-0](#) [LAS S G BLACK](#)