

Customer Information Sheet

DRAWING No.: S9111-45R

IF IN DOUBT - ASK

©

NOT TO SCALE

THIRD ANGLE PROJECTION

ALL DIMENSIONS IN mm

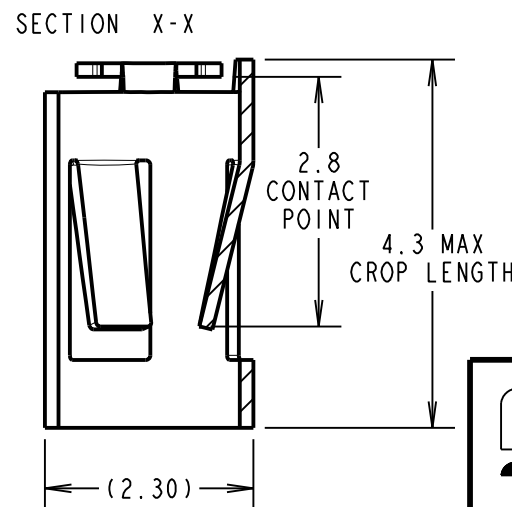
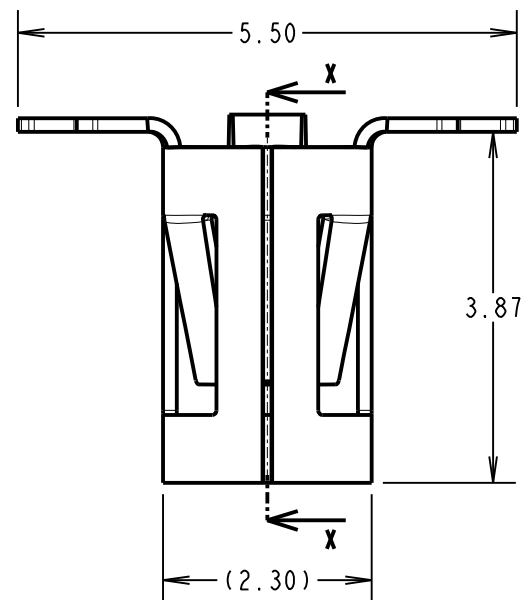
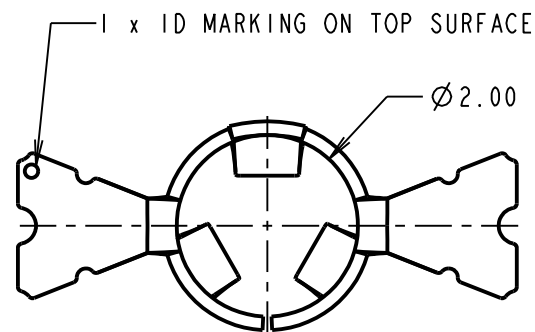
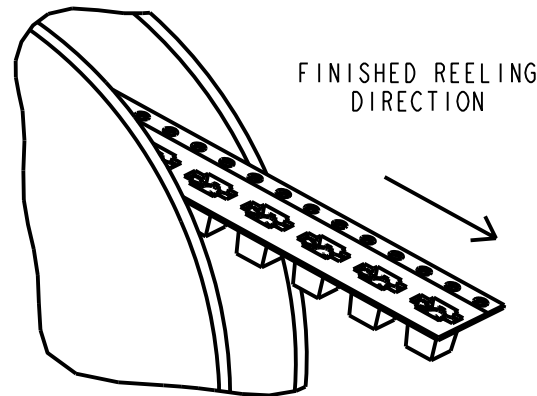
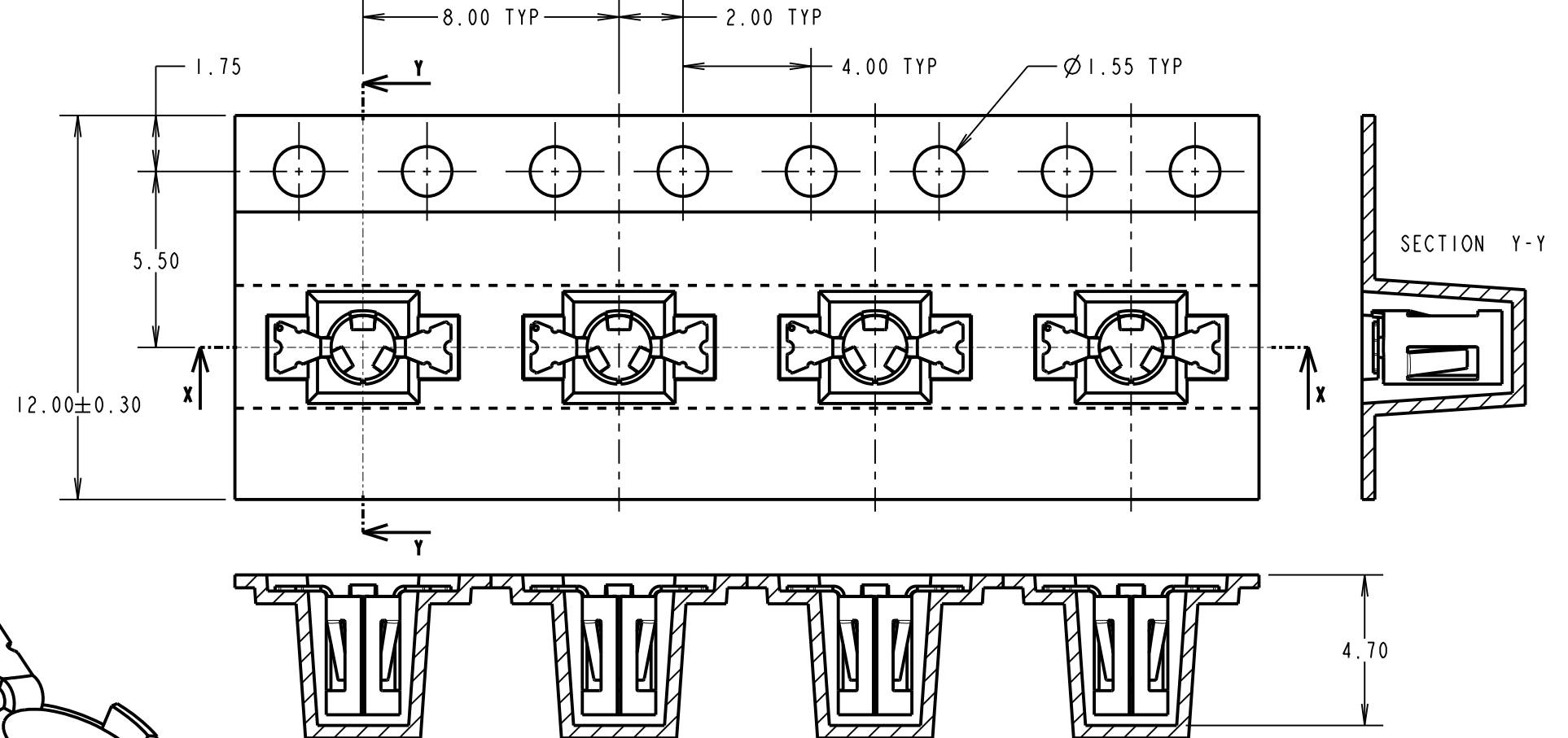
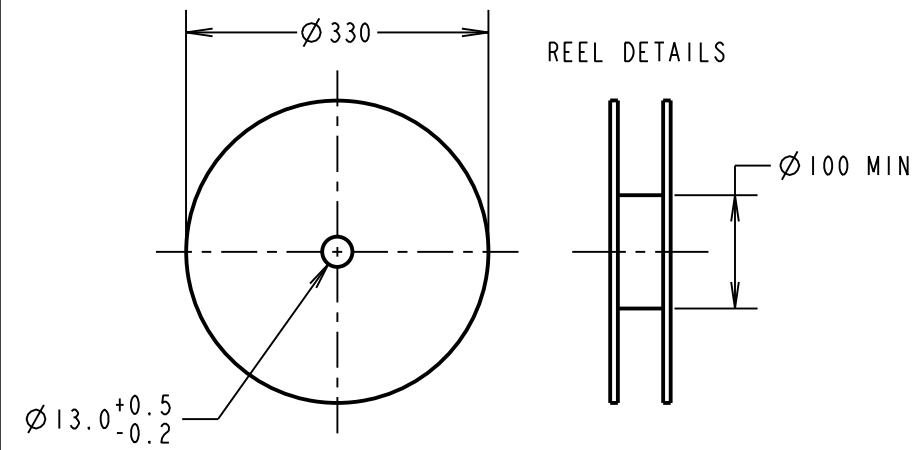

COMPONENT SPECIFICATION
 MATERIAL = BERYLLIUM COPPER
 FINISH = 0.10µm - 0.17µm GOLD OVER
 1.0µm MIN NICKEL

ELECTRICAL:
 CURRENT RATING = 6A
 CONTACT RESISTANCE = 15mΩ MAX

MECHANICAL:
 MAX INSERTION FORCE:
 Ø 1.50mm PIN = 3.5N
 Ø 1.90mm PIN = 17.0N
 MIN WITHDRAWAL FORCE:
 Ø 1.50mm PIN = 0.5N
 Ø 1.90mm PIN = 1.0N
 DURABILITY = 500 CYCLES

ENVIRONMENTAL:
 OPERATING TEMPERATURE = -50°C TO +125°C

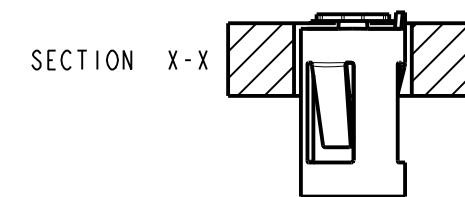
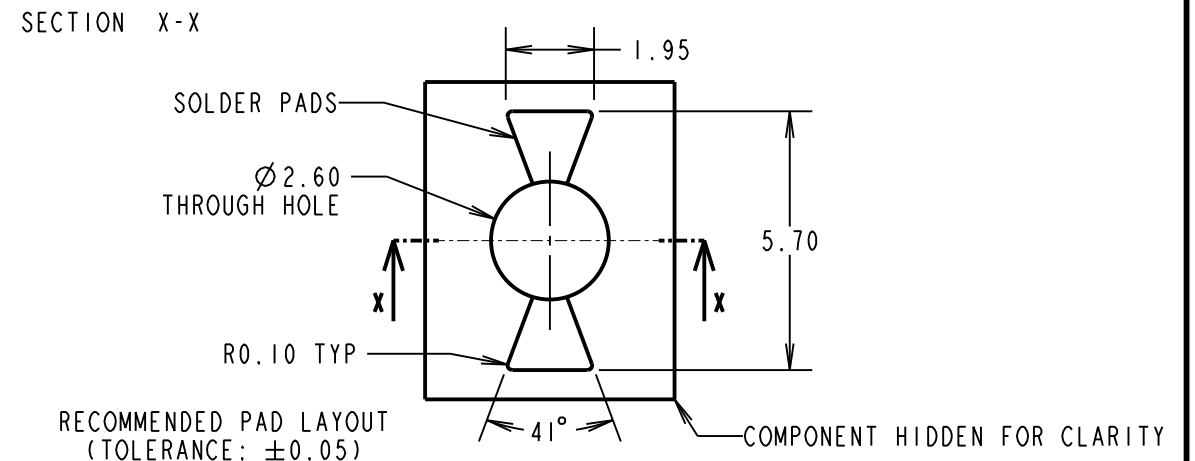

NOTES:
 1. QUANTITY OF COMPONENTS PER REEL = 1400.
 2. THIS PRODUCT IS TAPED AND REELED IN GENERAL ACCORDANCE WITH EIA-481-2 (ELECTRONICS INDUSTRIES ASSOCIATION).

RA	6	04.03.20	30020
NAME	ISS.	DATE	C/NOTE
APPROVED:		R. ALEXANDER	
CHECKED:		R. PORTLOCK	
DRAWN:		S. BENNETT	
CUSTOMER REF.:			
ASSEMBLY DRG:			

HARWIN

www.harwin.com
 technical@harwin.com

THIS DRAWING AND ANY INFORMATION OR DESCRIPTIVE MATTER SET OUT HEREON ARE CONFIDENTIAL AND COPYRIGHT PROPERTY OF THE HARWIN GROUP AND MUST NOT BE DISCLOSED, LOANED, COPIED OR USED FOR MANUFACTURING, TENDERING OR FOR ANY OTHER PURPOSE WITHOUT THEIR WRITTEN PERMISSION.

TOLERANCES
 X. = ±1mm
 X.X = ±0.50mm
 X.XX = ±0.20mm
 X.XXX = ±0.01mm
 ANGLES = ±5°
 UNLESS STATED

MATERIAL:
 SEE ABOVE
 FINISH: SEE ABOVE
 S/AREA: mm²

TITLE: SYCAMORE CONTACT
 Ø 1.50mm TOP ENTRY SOCKET
 IN TAPE & REEL

DRAWING NUMBER: S9111-45R

SHT 2 OF 2

X-ON Electronics

Largest Supplier of Electrical and Electronic Components

Click to view similar products for [Circuit Board Hardware - PCB category](#):

Click to view products by [Harwin manufacturer](#):

Other Similar products are found below :

[8919-0-00-15-00-00-03-0](#) [0135-0-15-01-30-27-04-0](#) [5970-1-15-01-32-14-04-0](#) [0149-0-15-15-30-27-04-0](#) [MBI 1 BLUE](#) [7305-0-15-15-47-14-10-0](#) [MLN 150/1 BLACK](#) [8579-0-15-80-11-27-10-0](#) [8579-1-15-15-11-27-10-0](#) [8830-0-15-01-22-14-10-0](#) [8836-0-00-21-00-00-03-0](#) [PRUEF 2 RED](#) [9976-0-00-00-00-00-03-0](#) [PW1616](#) [1215-3-05-00-00-00-01-0](#) [1231](#) [1303-0-15-15-47-14-04-0](#) [1404-3](#) [1404-4](#) [1406-4](#) [1407-3](#) [1406-3](#) [1407-4](#) [1408-3](#) [1424-4](#) [1427-3](#) [1419-4](#) [1426-4](#) [1548-103](#) [1938-0-00-00-00-00-03-0](#) [1942-0-00-00-00-00-03-0](#) [2101-3-00-44-00-00-07-0](#) [2108-2-00-50-00-00-07-0](#) [2109-2-00-44-00-00-07-0](#) [2110-2-00-44-00-00-07-0](#) [2111-2-00-00-00-00-07-0](#) [2113-4-00-44-00-00-07-0](#) [2301-3-00-44-00-00-07-0](#) [2308-1-00-50-00-00-07-0](#) [2313-2-00-00-00-00-07-0](#) [2315-2-01-44-00-00-07-0](#) [2333-1-00-50-00-00-07-0](#) [9000-0-00-00-00-00-03-0](#) [2506-2-00-50-00-00-07-0](#) [2507-2-01-44-00-00-07-0](#) [2508-2-00-44-00-00-07-0](#) [2561-2-00-44-00-00-07-0](#) [9220](#) [9234-0-15-15-30-14-10-0](#) [LAS S G BLACK](#)