

Features

- Low power consumption
- Low voltage drop
- Low temperature coefficient
- Voltage drop:50mV@10mA
- High input voltage (up to 35V)
- Output voltage accuracy: tolerance $\pm 1\%$
- TO92、SOT23 and SOT89 package
- PSRR:60dB@KHz

Applications

- Battery-powered equipment
- Communication equipment
- Audio/Video equipment

General Description

The HE2021 series is a set of three-terminal low power high voltage regulators implemented in CMOS technology. They allow input voltages as high as 35V. They are available with several fixed output voltages ranging from 3.0V to 5.0V. CMOS technology ensures low voltage drop and low quiescent current. Although designed primarily as fixed voltage regulators, these devices can be used with external components to obtain variable voltages and currents.

Selection Table

Part No.	Output Voltage	Package	Marking
HE2021Axx	2.5V	TO92 SOT89 SOT23-3L SOT23-5L	XXH (for TO92) HEXXH (for SOT89) XXH(for SOT23-3) XXH(for SOT23-5)
HE2021Axx	3.0V		
HE2021Axx	3.3V		
HE2021Axx	3.6V		
HE2021Axx	4.4V		
HE2021Axx	5.0V		

Order Information

HE2021A①②③④⑤

Designator	Symbol	Description
① ②	Integer	Output Voltage(3.0~5.0V)
③	H	Standard
④	T	Package:TO-92
	P	Package:SOT89
	M	Package:SOT23-3
	M5	Package:SOT23-5
⑤	R	RoHS / Pb Free
	G	Halogen Free

Block Diagram

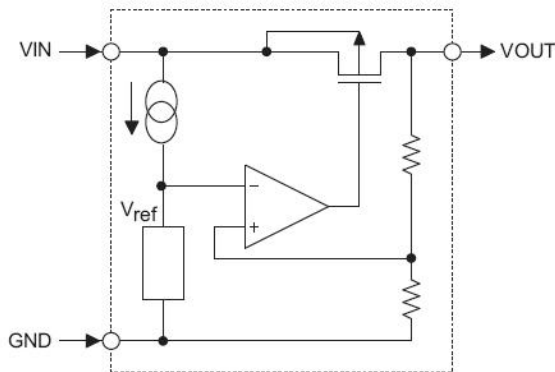

Pin Assignment

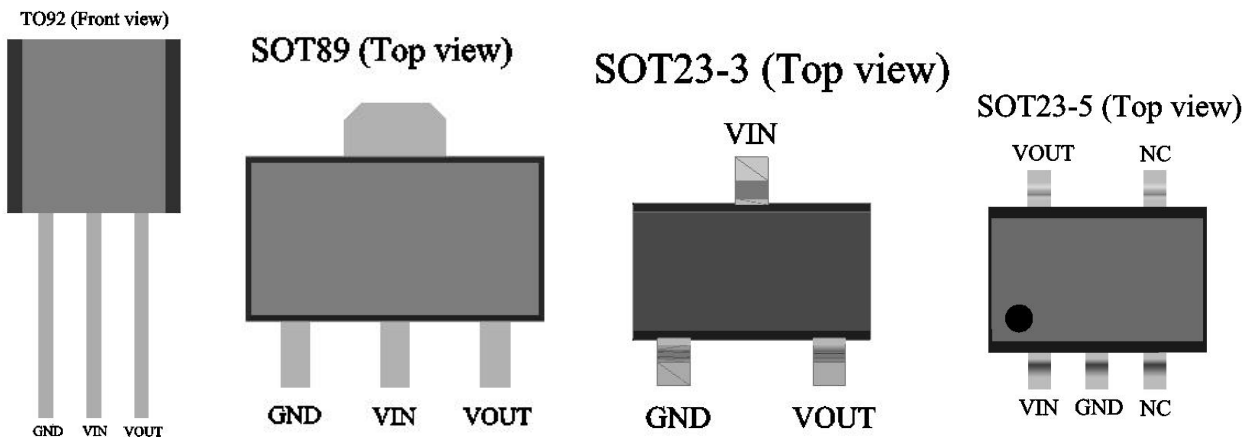

Absolute Maximum Ratings

Supply Voltage-0.3V to 35V Storage Temperature-50°C to 125°C
 Operating Temperature-40°C to 85°C

Note: These are stress ratings only. Stresses exceeding the range specified under "Absolute Maximum Ratings" may cause substantial damage to the device. Functional operation of this device at other conditions beyond those listed in the specification is not implied and prolonged exposure to extreme conditions may affect device reliability.

Thermal Information

Symbol	Parameter	Package	Max.	Unit
θ_{JA}	Thermal Resistance (Junction to Ambient) (Assume no ambient airflow, no heat sink)	SOT23	500	°C/W
		TO92	200	°C/W
		SOT89	200	°C/W
P_D	Power Dissipation	SOT23	0.20	W
		TO92	0.50	W
		SOT89	0.50	W

Note: P_D is measured at $T_a = 25^\circ\text{C}$

Electrical Characteristics

HE2021A30, +3.0V Output Type

Symbol	Parameter	Test Conditions		Min.	Typ.	Max.	Unit
		V _{IN}	Conditions				
V _{OUT}	Output Voltage	8V	I _{OUT} =10mA	2.97	3.00	3.03	V
I _{OUT}	Output Current	6V	-	-	200	-	mA
ΔV _{OUT}	Load Regulation	8V	1mA ≤ I _{OUT} ≤ 20mA	-	40	60	mV
V _{DIF}	Voltage Drop(Note)	-	I _{OUT} =1mA, ΔV _{OUT} =2%	-	10	-	mV
ISS	Current Consumption	8V	No load	-	2.0	3.0	μA
$\frac{\Delta V_{OUT}}{\Delta V_{IN} \times V_{OUT}}$	Line Regulation	-	4V ≤ V _{IN} ≤ 37V I _{OUT} =1mA	-	0.3	-	%/V
V _{IN}	Input Voltage	-	-	-	-	35	V
$\frac{\Delta V_{OUT}}{\Delta T_a}$	Temperature Coefficient	8V	I _{OUT} =10mA 0°C < T _a < 100°C	-	±0.12	-	mV/°C

Note: Dropout voltage is defined as the input voltage minus the output voltage that produces a 1% change in the output voltage from the value at V_{IN} = V_{OUT}+2V with a fixed load.

HE2021A33, +3.3V Output Type

Symbol	Parameter	Test Conditions		Min.	Typ.	Max.	Unit
		V _{IN}	Conditions				
V _{OUT}	Output Voltage	8V	I _{OUT} =10mA	3.267	3.300	3.333	V
I _{OUT}	Output Current	6.3V	-	-	200	-	mA
ΔV _{OUT}	Load Regulation	8V	1mA ≤ I _{OUT} ≤ 20mA	-	40	60	mV
V _{DIF}	Voltage Drop(Note)	-	I _{OUT} =1mA, ΔV _{OUT} =2%	-	10	-	mV
ISS	Current Consumption	8V	No load	-	2.0	3.0	μA
$\frac{\Delta V_{OUT}}{\Delta V_{IN} \times V_{OUT}}$	Line Regulation	-	4.5V ≤ V _{IN} ≤ 37V I _{OUT} =1mA	-	0.3	-	%/V
V _{IN}	Input Voltage	-	-	-	-	35	V
$\frac{\Delta V_{OUT}}{\Delta T_a}$	Temperature Coefficient	8V	I _{OUT} =10mA 0°C < T _a < 100°C	-	±0.12	-	mV/°C

Note: Dropout voltage is defined as the input voltage minus the output voltage that produces a 1% change in the output voltage from the value at V_{IN} = V_{OUT}+2V with a fixed load.

HE2021A36, +3.6V Output Type

Symbol	Parameter	Test Conditions		Min.	Typ.	Max.	Unit
		V _{IN}	Conditions				
V _{OUT}	Output Voltage	8V	I _{OUT} =10mA	3.564	3.600	3.636	V
I _{OUT}	Output Current	6.6V	-	-	200	-	mA
ΔV _{OUT}	Load Regulation	8V	1mA ≤ I _{OUT} ≤ 20mA	-	40	60	mV
V _{DIF}	Voltage Drop(Note)	-	I _{OUT} =1mA, ΔV _{OUT} =2%	-	10	-	mV
ISS	Current Consumption	8V	No load	-	2.0	5.0	μA
$\frac{\Delta V_{OUT}}{\Delta V_{IN} \times V_{OUT}}$	Line Regulation	-	4.6V ≤ V _{IN} ≤ 37V I _{OUT} =1mA	-	0.3	-	%/V
V _{IN}	Input Voltage	-	-	-	-	35	V
$\frac{\Delta V_{OUT}}{\Delta T_a}$	Temperature Coefficient	8V	I _{OUT} =10mA 0°C < T _a < 100°C	-	±0.12	-	mV/°C

Note: Dropout voltage is defined as the input voltage minus the output voltage that produces a 1% change in the output voltage from the value at V_{IN} = V_{OUT}+2V with a fixed load.

HE2021A44, +4.4V Output Type

Symbol	Parameter	Test Conditions		Min.	Typ.	Max.	Unit
		V _{IN}	Conditions				
V _{OUT}	Output Voltage	8V	I _{OUT} =10mA	4.356	4.400	4.444	V
I _{OUT}	Output Current	7.4V	-	-	200	-	mA
ΔV _{OUT}	Load Regulation	8V	1mA ≤ I _{OUT} ≤ 20mA	-	40	60	mV
V _{DIF}	Voltage Drop(Note)	-	I _{OUT} =1mA, ΔV _{OUT} =2%	-	10	-	mV
ISS	Current Consumption	8V	No load	-	2.0	5.0	μA
$\frac{\Delta V_{OUT}}{\Delta V_{IN} \times V_{OUT}}$	Line Regulation	-	5.4V ≤ V _{IN} ≤ 38V I _{OUT} =1mA	-	0.3	-	%/V
V _{IN}	Input Voltage	-	-	-	-	35	V
$\frac{\Delta V_{OUT}}{\Delta T_a}$	Temperature Coefficient	8V	I _{OUT} =10mA 0°C < T _a < 100°C	-	±0.12	-	mV/°C

Note: Dropout voltage is defined as the input voltage minus the output voltage that produces a 1% change in the output voltage from the value at V_{IN} = V_{OUT}+2V with a fixed load.

HE2021A50, +5.0V Output Type

Symbol	Parameter	Test Conditions		Min.	Typ.	Max.	Unit
		V _{IN}	Conditions				
V _{OUT}	Output Voltage	8V	I _{OUT} =10mA	4.95	5.00	5.05	V
I _{OUT}	Output Current	8V	-	-	200	-	mA
ΔV _{OUT}	Load Regulation	8V	1mA ≤ I _{OUT} ≤ 20mA	-	40	60	mV
V _{DIF}	Voltage Drop(Note)	-	I _{OUT} =1mA, ΔV _{OUT} =2%	-	10	-	mV
ISS	Current Consumption	8V	No load	-	2.0	5.0	μA
$\frac{\Delta V_{OUT}}{\Delta V_{IN} \times V_{OUT}}$	Line Regulation	-	6V ≤ V _{IN} ≤ 39V I _{OUT} =1mA	-	0.3	-	%/V
V _{IN}	Input Voltage	-	-	-	-	35	V
$\frac{\Delta V_{OUT}}{\Delta T_a}$	Temperature Coefficient	8V	I _{OUT} =10mA 0°C < T _a < 100°C	-	±0.12	-	mV/°C

Note: Dropout voltage is defined as the input voltage minus the output voltage that produces a 1% change in the output voltage from the value at V_{IN} = V_{OUT}+2V with a fixed load.

Application Circuits

Basic Circuits

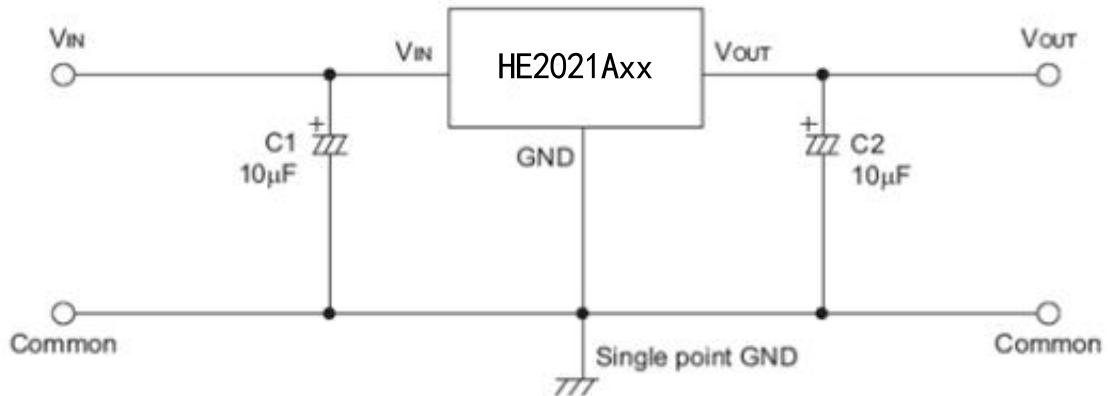

Package Information
3-pin SOT23-3 Outline Dimensions

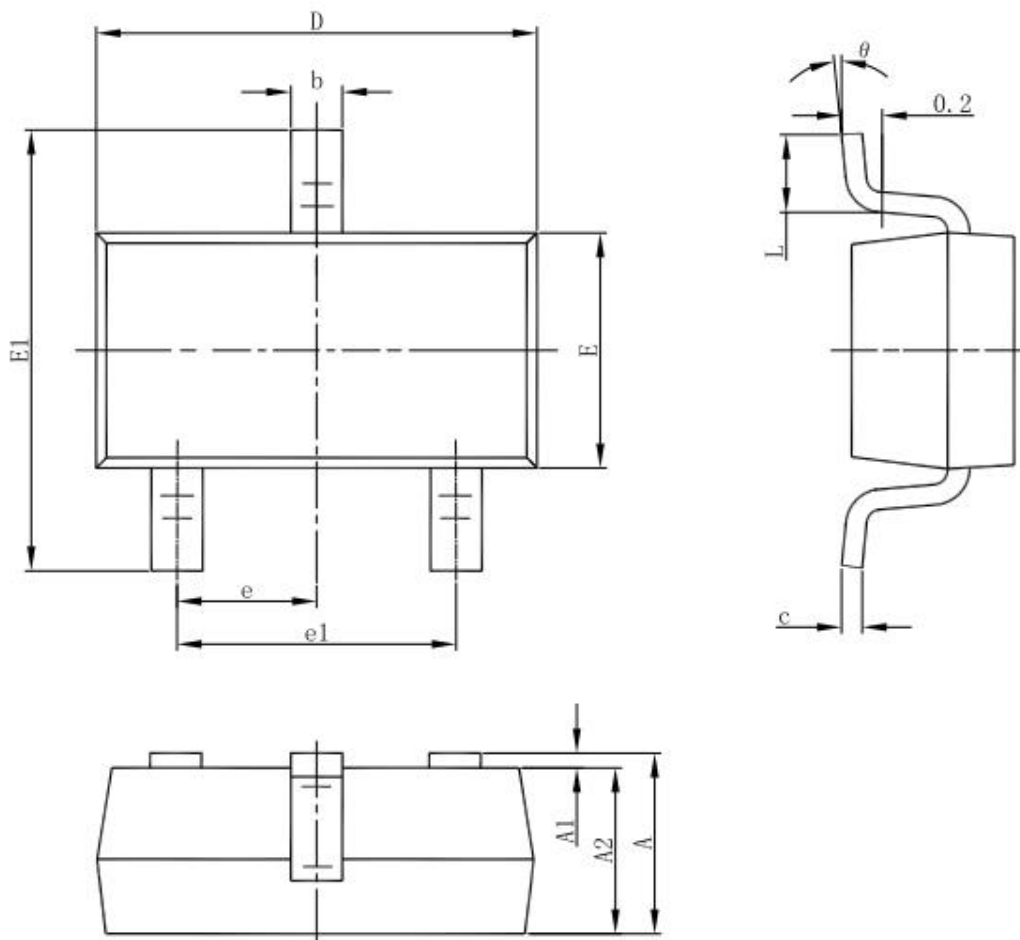

Symbol	Dimensions In Millimeters		Dimensions In Inches	
	Min	Max	Min	Max
A	1.050	1.250	0.041	0.049
A1	0.000	0.100	0.000	0.004
A2	1.050	1.150	0.041	0.045
b	0.300	0.500	0.012	0.020
c	0.100	0.200	0.004	0.008
D	2.820	3.020	0.111	0.119
E	1.500	1.700	0.059	0.067
E1	2.650	2.950	0.104	0.116
e	0.950(BSC)		0.037(BSC)	
e1	1.800	2.000	0.071	0.079
L	0.300	0.600	0.012	0.024
θ	0°	8°	0°	8°

3-pin TO92 Outline Dimensions

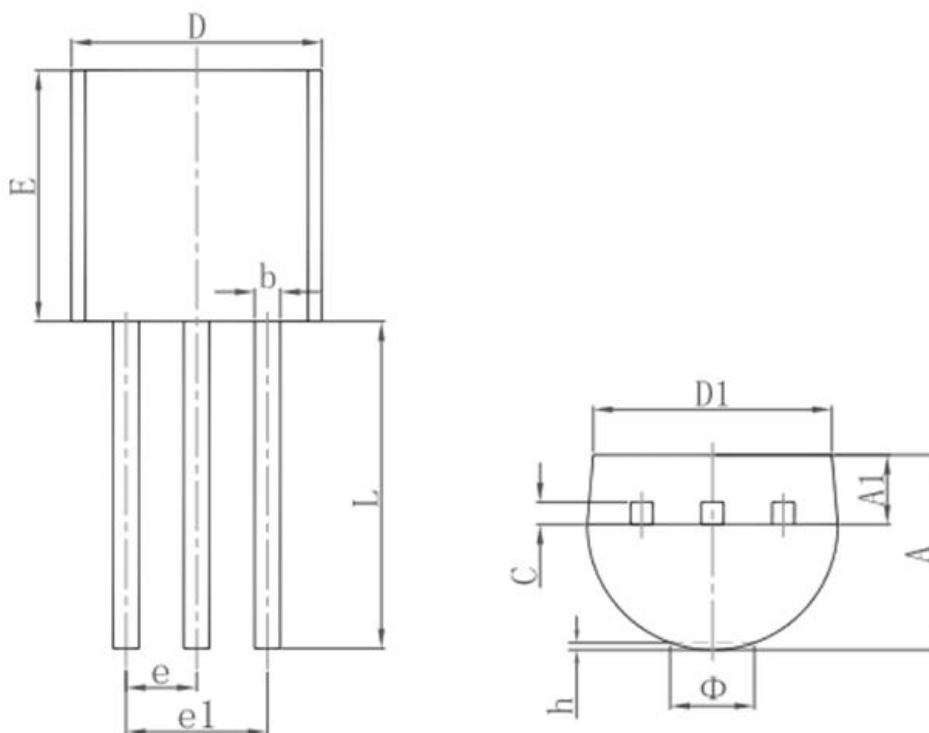

Symbol	Dimensions In Millimeters		Dimensions In Inches	
	Min.	Max.	Min.	Max.
A	3.300	3.700	0.130	0.146
A1	1.100	1.400	0.043	0.055
b	0.380	0.550	0.015	0.022
c	0.360	0.510	0.014	0.020
D	4.300	4.700	0.169	0.185
D1	3.430		0.135	
E	4.300	4.700	0.169	0.185
e	1.270 TYP.		0.050 TYP.	
e1	2.440	2.640	0.096	0.104
L	14.100	14.500	0.555	0.571
Φ		1.600		0.063
h	0.000	0.380	0.000	0.015

3-pin SOT89 Outline Dimensions

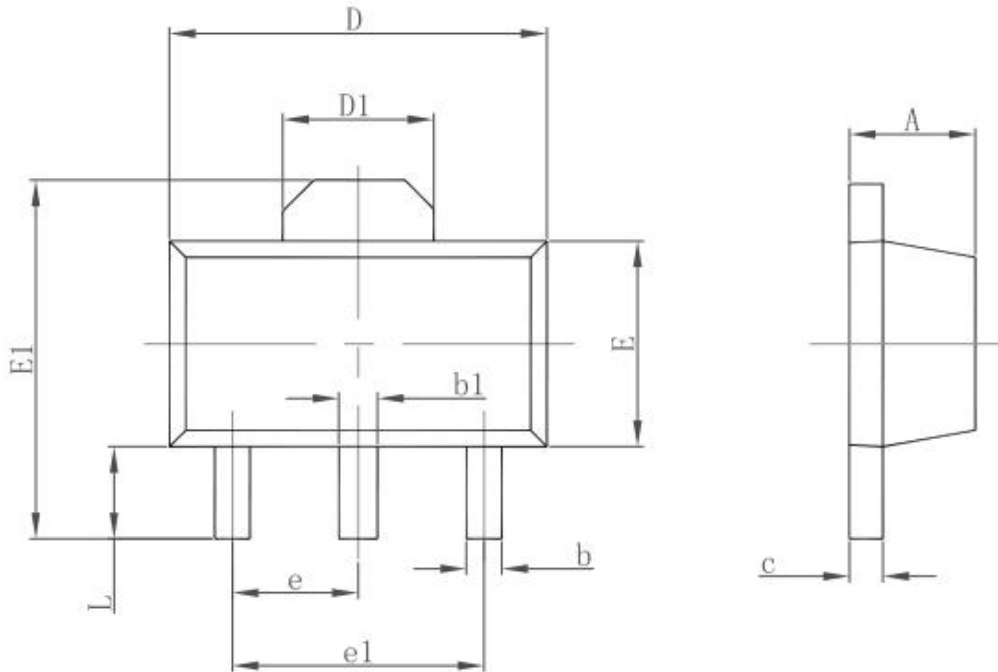

Symbol	Dimensions In Millimeters		Dimensions In Inches	
	Min.	Max.	Min.	Max.
A	1.400	1.600	0.055	0.063
b	0.320	0.520	0.013	0.020
b1	0.400	0.580	0.016	0.023
c	0.350	0.440	0.014	0.017
D	4.400	4.600	0.173	0.181
D1	1.550 REF.		0.061 REF.	
E	2.300	2.600	0.091	0.102
E1	3.940	4.250	0.155	0.167
e	1.500 TYP.		0.060 TYP.	
e1	3.000 TYP.		0.118 TYP.	
L	0.900	1.200	0.035	0.047

SOT23-5 Outline Dimensions

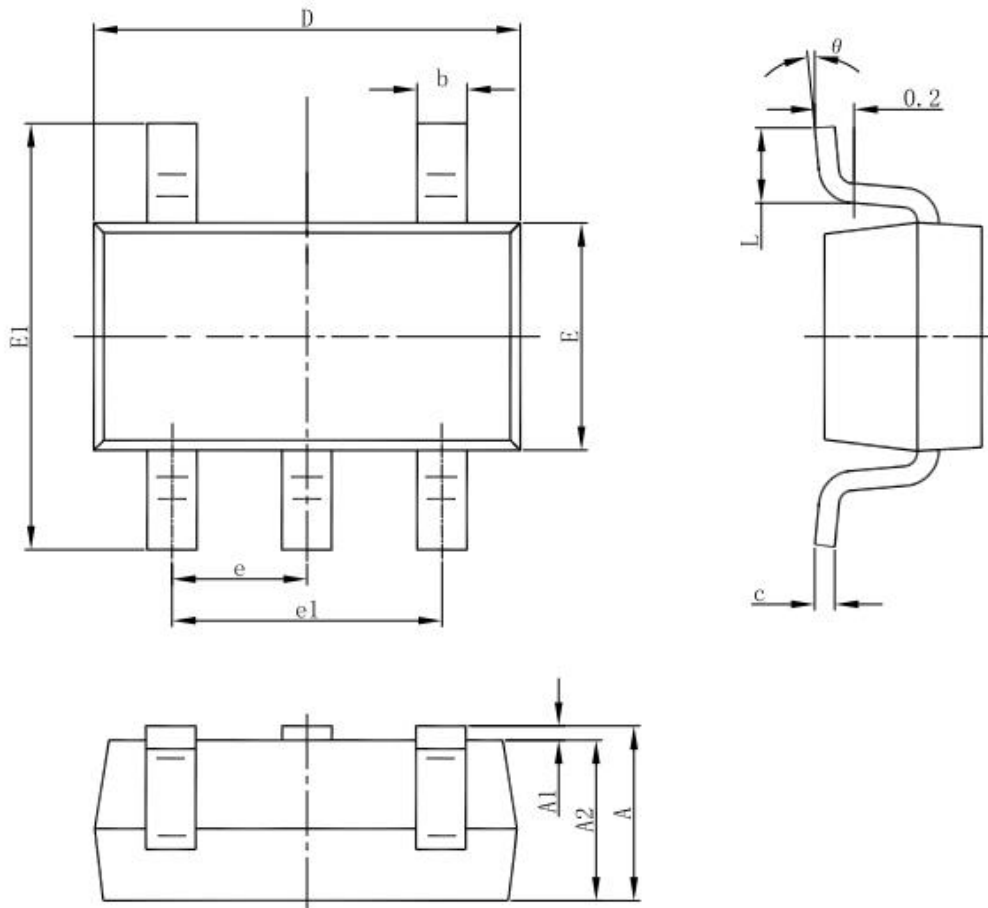

Symbol	Dimensions In Millimeters		Dimensions In Inches	
	Min	Max	Min	Max
A	1.050	1.250	0.041	0.049
A1	0.000	0.100	0.000	0.004
A2	1.050	1.150	0.041	0.045
b	0.300	0.500	0.012	0.020
c	0.100	0.200	0.004	0.008
D	2.820	3.020	0.111	0.119
E	1.500	1.700	0.059	0.067
E1	2.650	2.950	0.104	0.116
e	0.950(BSC)		0.037(BSC)	
e1	1.800	2.000	0.071	0.079
L	0.300	0.600	0.012	0.024
θ	0°	8°	0°	8°

X-ON Electronics

Largest Supplier of Electrical and Electronic Components

Click to view similar products for [Linear Voltage Regulators](#) category:

Click to view products by [HEERMICR](#) manufacturer:

Other Similar products are found below :

[LV5684PVD-XH](#) [MCDTSA6-2R](#) [L7815ACV-DG](#) [714954EB](#) [ZMR500QFTA](#) [BA033LBSG2-TR](#) [LV5680P-E](#) [L79M05T-E](#) [L78LR05D-MA-E](#) [NCV317MBTG](#) [NTE7227](#) [MP2018GZD-33-P](#) [MP2018GZD-5-P](#) [LV5680NPVC-XH](#) [LT1054CN8](#) [ZTS6538SE](#) [UA78L09CLP](#) [UA78L09CLPR](#) [CAT6221-PPTD-GT3](#) [MC78M09CDTRK](#) [NCV51190MNTAG](#) [78M05](#) [HT7150-1](#) [UM1540DB-18](#) [XC6234H281VR-G](#) [WL2834CA-6/TR](#) [TPL730F33-5TR](#) [TLS850F1TA](#) [V50](#) [TPS549B22RVFR](#) [UM1540DB-33](#) [WL9200P3-50B](#) [WL9100P3-33B](#) [WL9005D4-33](#) [XC6219B152MR](#) [WL2855K33-3/TR](#) [PJ54BM33SE](#) [PJ9500M25SA](#) [MD7218E33PC1](#) [H7533-2PR](#) [SK7812AU](#) [SD1A30](#) [78L33](#) [TP78L33T3](#) [L78L33ACUTR](#) [SK6513ST3A-50](#) [SK6054D4-09](#) [SK6054D4-18](#) [SK6054D4-11](#) [SK6054D4-10](#) [LM79L12F](#)