

### Features

- Low voltage drop: 0.17V@100mA
- Low Quiescent Current: 2.0uA
- High input voltage: 15V
- Output voltage accuracy: tolerance  $\pm 2\%$
- Low temperature coefficient
- Built-in current limiter
- Large Output Current: >0.5A
- SOT89,SOT89-5,SOT23-3 and SOT23-5 packages

### Applications

- Battery-powered equipment
- GRS Receivers
- Hand-Hold Equipment
- Wireless LAN

### General Description

The HE62XXM series is a group of positive voltage output, three-pin regulators, that provide a high current even when the input/output voltage differential is small. Low power consumption and high accuracy is achieved through CMOS and laser trimming technologies.

The HE62XXM consists of a high-precision voltage reference, an error amplification circuit, and a current limited output driver. Transient response to load variations have improved in comparison to the existing series. SOT89, SOT89-5,SOT23-3 and SOT23-5 packages are available.

### Selection Table

Part No.	Output Voltage	Package	Marking
HE6218xx	1.8V	SOT89 SOT89-5 SOT23 SOT23-5	Refer to Marking rule
HE6228xx	2.8V		
HE6230xx	3.0V		
HE6233xx	3.3V		
HE6236xx	3.6V		
HE6240xx	4.0V		
HE6245xx	4.5V		
HE6250xx	5.0V		

### Order Information

HE62①②③④⑤

Designator	Symbol	Description
① ②	Integer	Output Voltage(1.8~5.0V)
③	M	Standard
④	P	Package:SOT89
	P5	Package:SOT89-5
	M	Package:SOT23-3
	M5	Package:SOT23-5
⑤	R	RoHS / Pb Free
	G	Halogen Free

Note: "①②" stands for output voltages. Other voltages can be specially customized

### Block Diagram

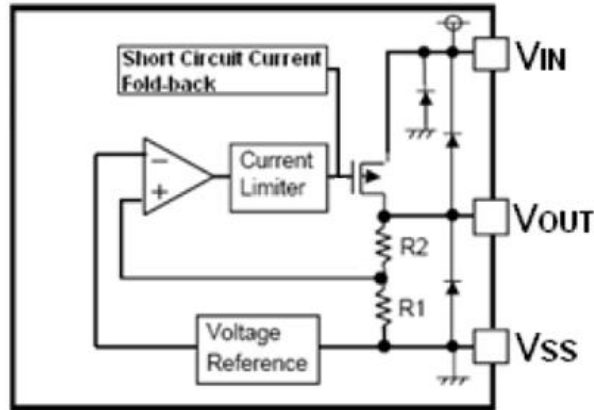

### Pin Assignment

SOT89 (Top view)

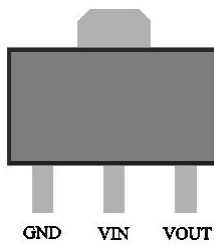

SOT89-5 (Top view)

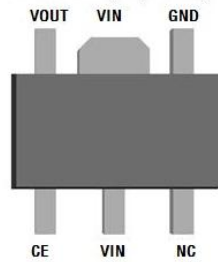

SOT23-3 (Top view)

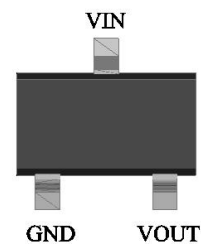

SOT23-5 (Top view)

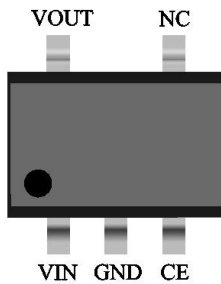

### Absolute Maximum Ratings

Supply Voltage .....	2.0V to 18V	Storage Temperature .....	-40°C to 125°C
Operating Temperature .....	-40°C to 85°C		

Note: These are stress ratings only. Stresses exceeding the range specified under "Absolute Maximum Ratings" may cause substantial damage to the device. Functional operation of this device at other conditions beyond those listed in the specification is not implied and prolonged exposure to extreme conditions may affect device reliability.

### Marking Rule

(1) SOT23-3 and SOT23-5

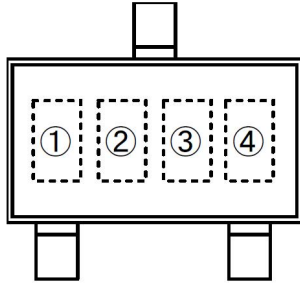

SOT-23  
(TOP VIEW)

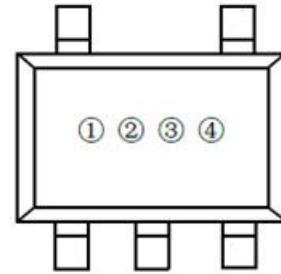

SOT23-5  
(TOP VIEW)

List of Product Name vs. Product Code

Product Name	Product Code		
	(1)	(2)	(3)
HE6212	S	A	A
HE6213	S	A	B
HE6214	S	A	C
HE6215	S	A	D
HE6216	S	A	E
HE6217	S	A	F
HE6218	S	A	G
HE6219	S	A	I
HE6220	S	A	J
HE6221	S	A	K
HE6222	S	A	L
HE6223	S	A	M
HE6224	S	A	N
HE6225	S	A	O
HE6226	S	A	P
HE6227	S	A	Q
HE6228	S	A	R
HE6229	S	A	T
HE6230	S	A	U
HE6231	S	A	V

Product Name	Product Code		
	(1)	(2)	(3)
HE6232	S	A	W
HE6233	S	A	X
HE6234	S	A	Y
HE6235	S	A	Z
HE6236	S	B	A
HE6237	S	B	B
HE6238	S	B	C
HE6239	S	B	D
HE6240	S	B	E
HE6241	S	B	F
HE6242	S	B	J
HE6243	S	B	H
HE6244	S	B	I
HE6245	S	B	J
HE6246	S	B	K
HE6247	S	B	L
HE6248	S	B	M
HE6249	S	B	N
HE6250	S	B	O

**NOTE: SOT23-5, the last is Z**

**(2) SOT89 and SOT89-5**

SOT89 (Top View)

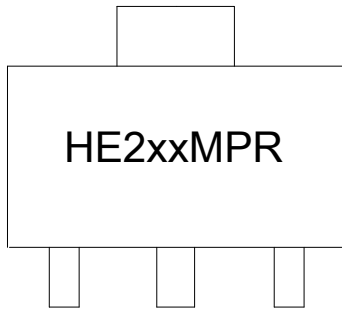

SOT89-5 (Top View)

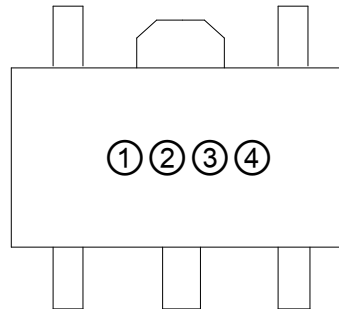

Product Code: E

Output Voltage Code:

Vout	Code	Vout	Code	Vout	Code
1.5V	1	2.7V	C	3.9V	O
1.6V	2	2.8V	D	4.0V	P
1.7V	3	2.9V	E	4.1V	Q
1.8V	4	3.0V	F	4.2V	R
1.9V	5	3.1V	G	4.3V	S
2.0V	6	3.2V	H	4.4V	T
2.1V	7	3.3V	I	4.5V	U
2.2V	8	3.4V	J	4.6V	V
2.3V	9	3.5V	K	4.7V	W
2.4V	0	3.6V	L	4.8V	X
2.5V	A	3.7V	M	4.9V	Y
2.6V	B	3.8V	N	5.0V	Z

Data Code: XX

Note: The last two of them are based on the time of this product which is the first time into production, and the third is the launch of this product ,it can be in 1 ~ 9 , which is expressed in "0" in October, in November with an "A", in December with "B"; the fourth is of the launch of the product, such as expressed in "0" in 2010, in "3" in 2013.

### Electrical Characteristics

HE62XXM for any output voltage

(Ta=25°C)

Parameter	Symbol	Conditions	Min.	Typ.	Max.	Unit
Output Voltage	Vout	Vin=Vout+1V 1.0mA≤Iout≤30mA	Vout×0.98	--	Vout×1.02	V
Output Current*1	Iout	Vin-Vout=1V	500	--	--	mA
Low dropout*2	Vdrop	Refer to the next table				
Line Regulation	$\frac{\Delta V_{OUT}}{\Delta V_{IN} \times V_{OUT}}$	1.6V≤Vin≤8V Iout=100mA	--	0.05	0.2	%/V
Load Regulation	ΔVout	Vin= Vout+1V 1.0mA≤Iout≤100mA	--	12	30	mV
Output voltage Temperature Coefficiency	$\frac{\Delta V_{OUT}}{\Delta Ta}$	Iout=30mA 0°C≤Ta≤70°C	--	±100	--	Ppm/°C
PSRR	PSRR	F=1KHz Vin=Vout+1V	--	40	--	dB
Supply Current	Iss1	--	--	1	2	uA
Input Voltage	Vin	--	--	--	15	V

### Electrical Characteristics by Output Voltage:

Output Voltage Vout(V)	Dropout Voltage Vdif (V)		
	Conditions	Typ.	Max.
Vout ≤ 2.0V	Iout=60 mA	0.1	0.12
2.0 < Vout ≤ 3.0	Iout=80 mA	0.12	0.14
3.0 < Vout ≤ 4.0	Iout=100 mA	0.16	0.18
4.0 < Vout ≤ 5.0		0.17	0.18
3.0 < Vout ≤ 4.0	Iout=200 mA	0.21	0.24
4.0 < Vout ≤ 6.0		0.20	0.22
3.0 < Vout ≤ 4.0	Iout=500 mA	0.8	0.85
4.0 < Vout ≤ 6.0		0.75	0.80

### Typical Application

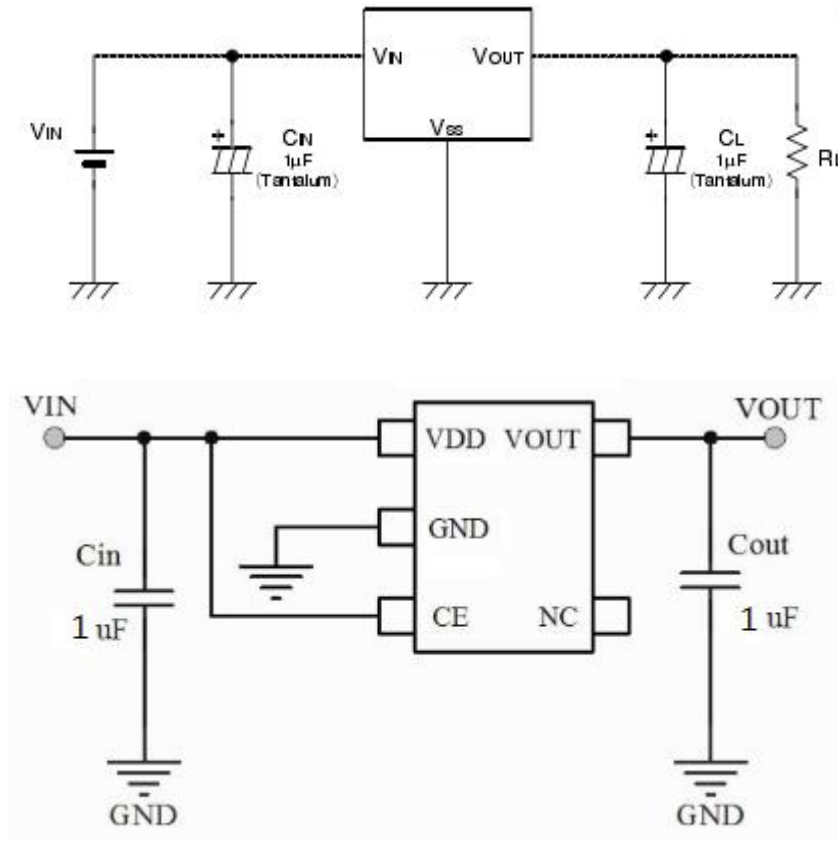

Note1: Input capacitor  $C_{IN}=1\mu F$ .

Note2: Output capacitor  $C_{OUT}=1\mu F/6.8\mu F$  (1uF Tantalum capacitor or 6.8uF ceramic capacitor is recommended).

### Typical Performance Characteristics

(1) Output Voltage vs Input voltage

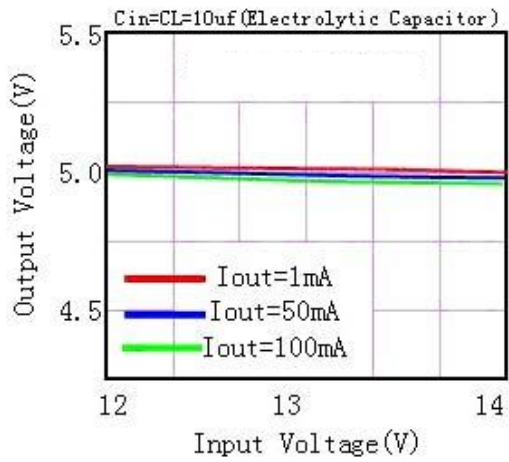
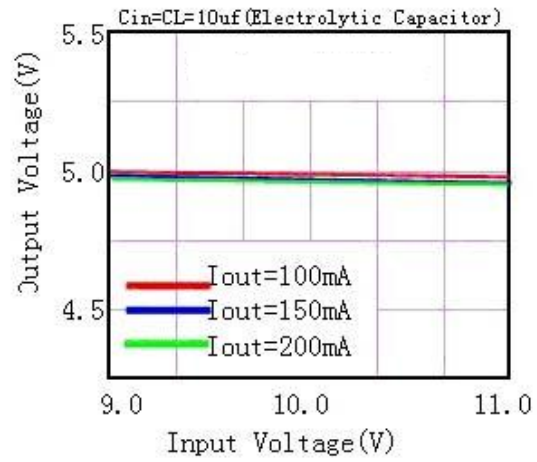
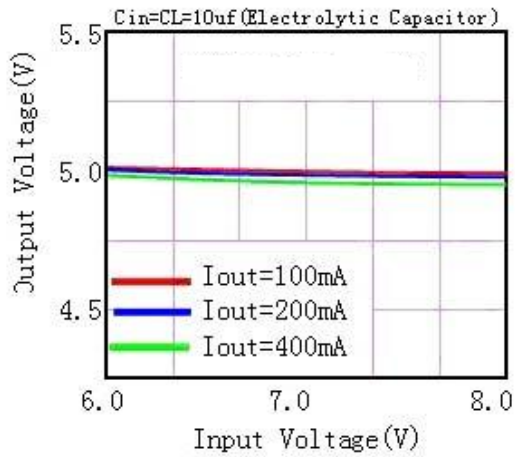

(2) Output Voltage vs. Output Current

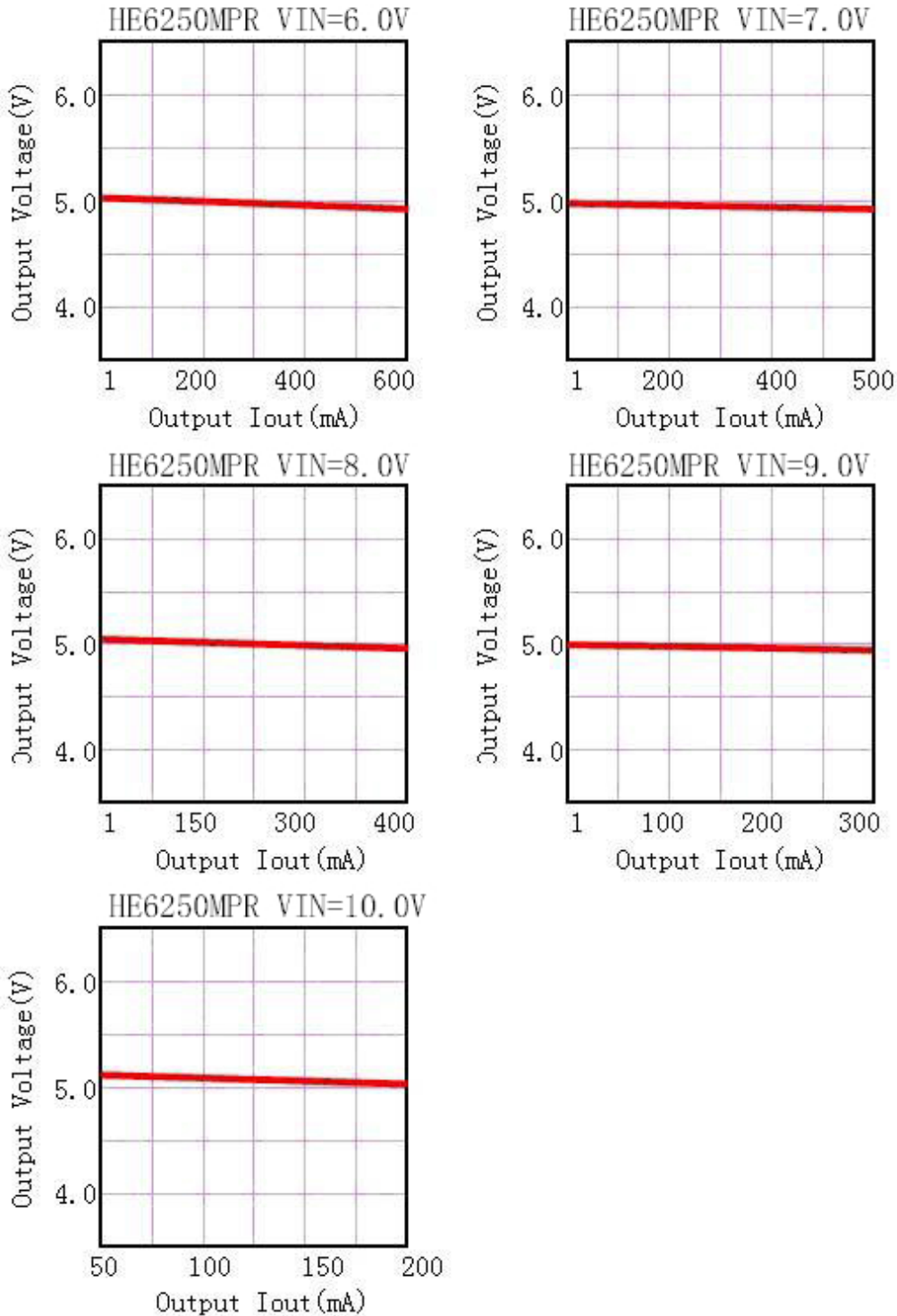



(3) Output Voltage vs.Ambient Temperature

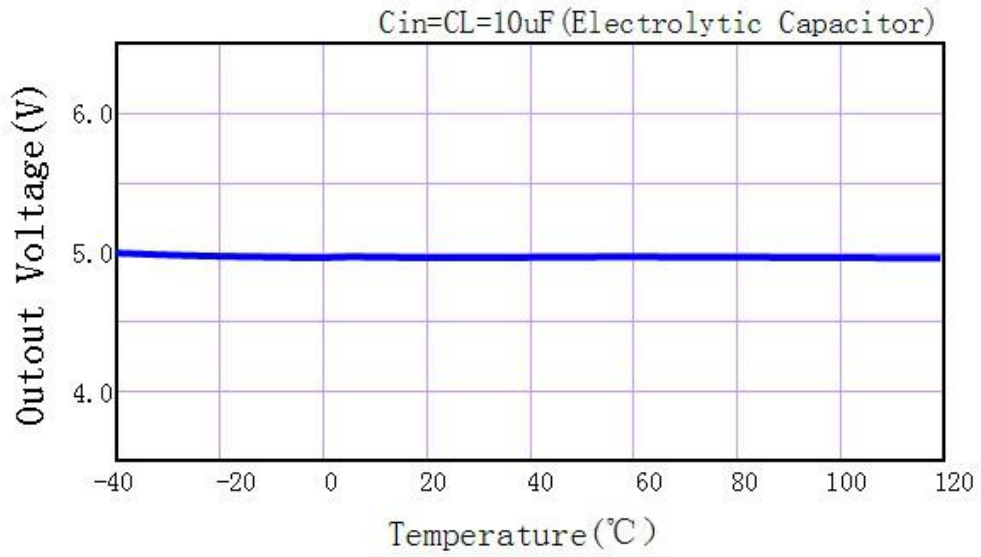

### Package Information

#### 3-pin SOT89 Outline Dimensions

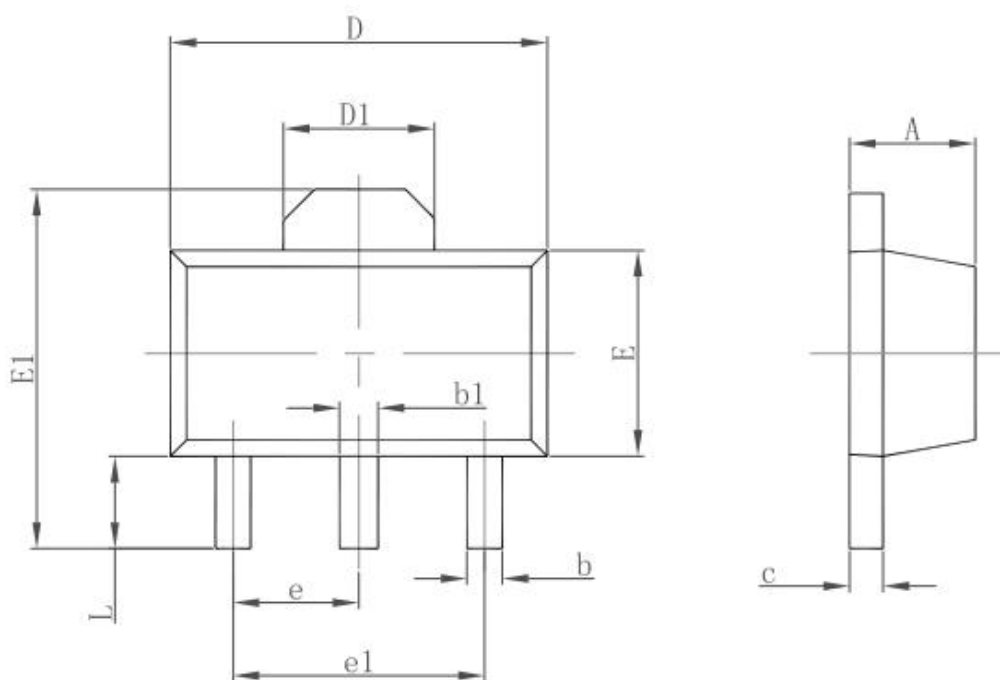

Symbol	Dimensions In Millimeters		Dimensions In Inches	
	Min.	Max.	Min.	Max.
A	1.400	1.600	0.055	0.063
b	0.320	0.520	0.013	0.020
b1	0.400	0.580	0.016	0.023
c	0.350	0.440	0.014	0.017
D	4.400	4.600	0.173	0.181
D1	1.550 REF.		0.061 REF.	
E	2.300	2.600	0.091	0.102
E1	3.940	4.250	0.155	0.167
e	1.500 TYP.		0.060 TYP.	
e1	3.000 TYP.		0.118 TYP.	
L	0.900	1.200	0.035	0.047

**SOT89-5 Outline Dimensions**

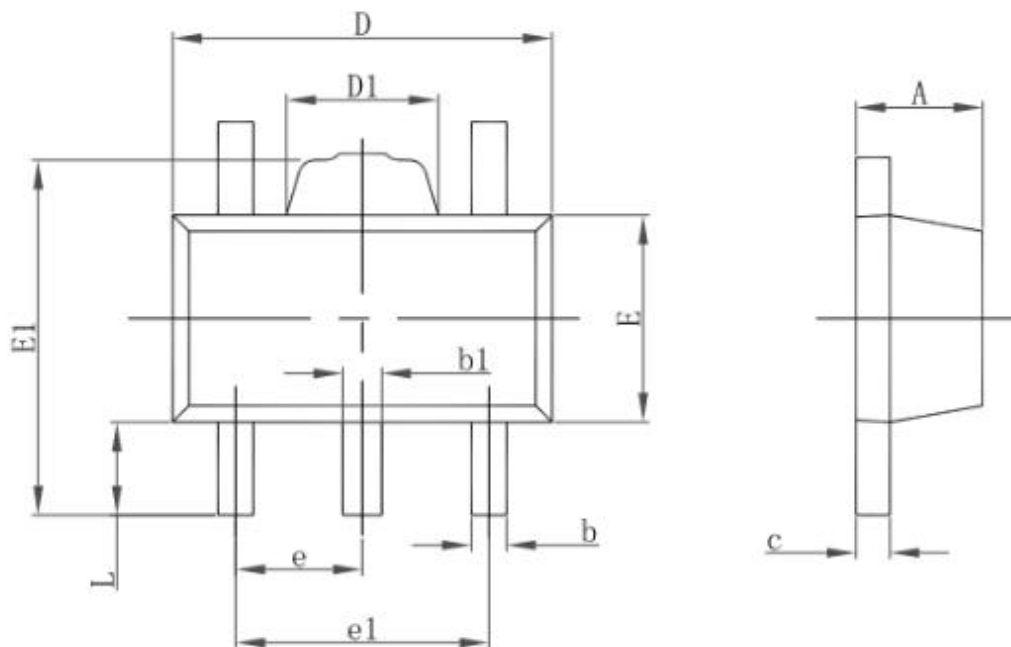

Symbol	Dimensions In Millimeters		Dimensions In Inches	
	Min.	Max.	Min.	Max.
A	1.400	1.600	0.055	0.063
b	0.320	0.520	0.013	0.020
b1	0.360	0.560	0.014	0.022
c	0.350	0.440	0.014	0.017
D	4.400	4.600	0.173	0.181
D1	1.400	1.800	0.055	0.071
E	2.300	2.600	0.091	0.102
E1	3.940	4.250	0.155	0.167
e	1.500TYP.		0.060TYP.	
e1	2.900	3.100	0.114	0.122
L	0.900	1.100	0.035	0.043

### 3-pin SOT23-3 Outline Dimensions

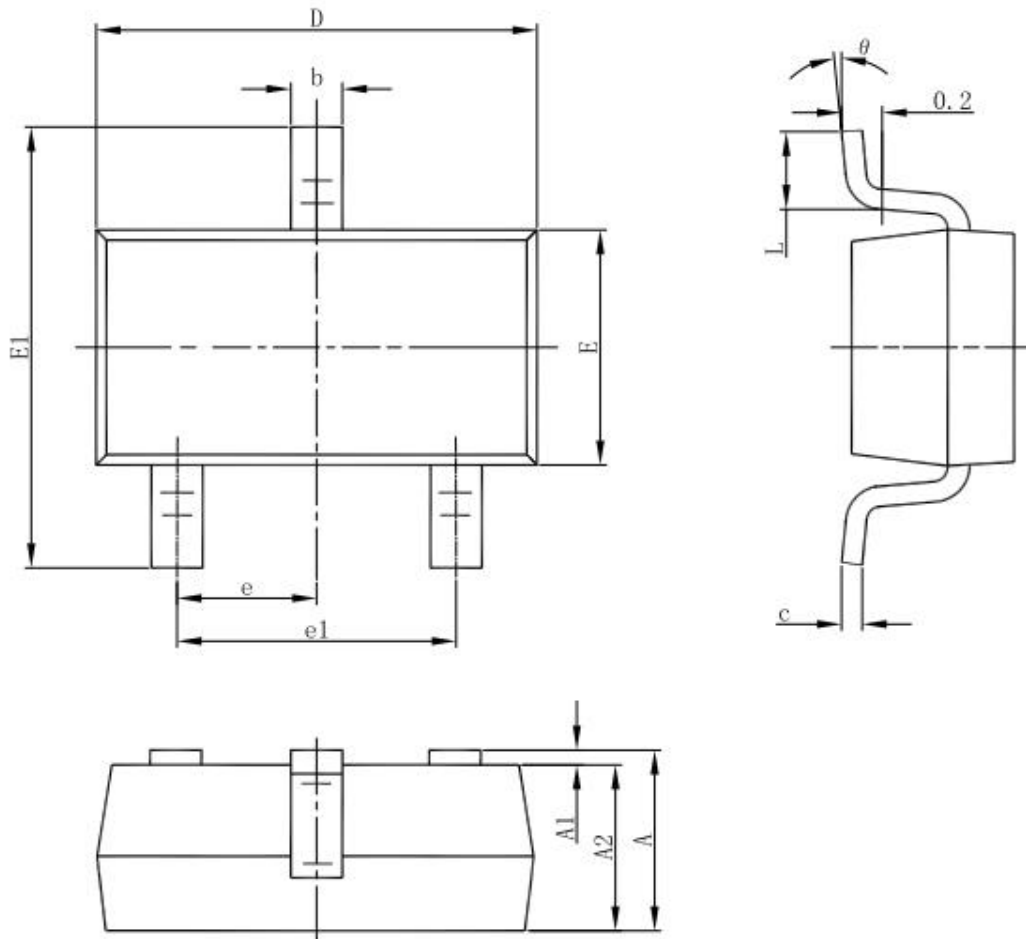

Symbol	Dimensions In Millimeters		Dimensions In Inches	
	Min	Max	Min	Max
A	1.050	1.250	0.041	0.049
A1	0.000	0.100	0.000	0.004
A2	1.050	1.150	0.041	0.045
b	0.300	0.500	0.012	0.020
c	0.100	0.200	0.004	0.008
D	2.820	3.020	0.111	0.119
E	1.500	1.700	0.059	0.067
E1	2.650	2.950	0.104	0.116
e	0.950(BSC)		0.037(BSC)	
e1	1.800	2.000	0.071	0.079
L	0.300	0.600	0.012	0.024
θ	0°	8°	0°	8°

### SOT23-5 Outline Dimensions

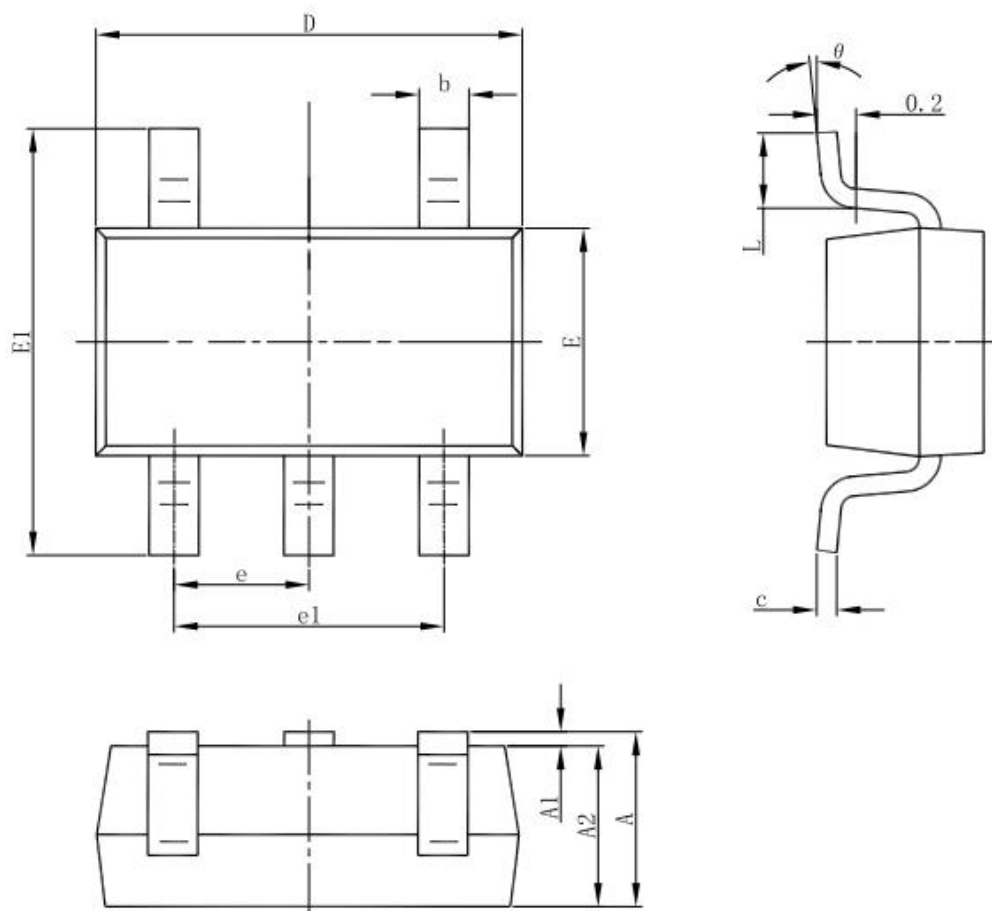

Symbol	Dimensions In Millimeters		Dimensions In Inches	
	Min	Max	Min	Max
A	1.050	1.250	0.041	0.049
A1	0.000	0.100	0.000	0.004
A2	1.050	1.150	0.041	0.045
b	0.300	0.500	0.012	0.020
c	0.100	0.200	0.004	0.008
D	2.820	3.020	0.111	0.119
E	1.500	1.700	0.059	0.067
E1	2.650	2.950	0.104	0.116
e	0.950(BSC)		0.037(BSC)	
e1	1.800	2.000	0.071	0.079
L	0.300	0.600	0.012	0.024
θ	0°	8°	0°	8°

## X-ON Electronics

Largest Supplier of Electrical and Electronic Components

*Click to view similar products for [Linear Voltage Regulators](#) category:*

*Click to view products by [HEERMICR](#) manufacturer:*

Other Similar products are found below :

[LV5684PVD-XH](#) [MCDTSA6-2R](#) [L7815ACV-DG](#) [LV56801P-E](#) [UA7805CKC](#) [714954EB](#) [ZMR500QFTA](#) [BA033LBSG2-TR](#)  
[NCV78M05ABDTRKG](#) [LV5680P-E](#) [L79M05T-E](#) [L78LR05D-MA-E](#) [NCV317MBTG](#) [NTE7227](#) [MP2018GZD-33-P](#) [MP2018GZD-5-P](#)  
[LV5680NPVC-XH](#) [ZTS6538SE](#) [UA78L09CLP](#) [UA78L09CLPR](#) [CAT6221-PPTD-GT3](#) [MC78M09CDTRK](#) [NCV51190MNTAG](#)  
[BL1118CS8TR1833](#) [BL8563CKETR18](#) [BL8077CKETR33](#) [BL9153-33CC3TR](#) [BL9161G-15BADRN](#) [BL9161G-28BADRN](#)  
[BRCO7530MMC](#) [CJ7815B-TFN-ARG](#) [LM317C](#) [GM7333K](#) [GM7350K](#) [XC6206P332MR](#) [HT7533](#) [LM7912S/TR](#) [LT1764S/TR](#) [LM7805T](#)  
[LM338T](#) [LM1117IMP-3.3/TR](#) [HT1117AM-3.3](#) [HT7550S](#) [AMS1117-3.3](#) [HT7150S](#) [78L12](#) [HT7550](#) [HT7533-1](#) [HXY6206I-2.5](#) [HT7133](#)