

Features

- Low power consumption
- High input voltage (up to 18V)
- Low voltage drop
- Output voltage accuracy: tolerance $\pm 2\%$
- Low temperature coefficient
- SOT89, SOT23 package

Applications

- Battery-powered equipment
- Audio/Video equipment
- Communication equipment

General Description

The HE65XXM series is a set of three-terminal low power high voltage regulators implemented in CMOS technology. They allow input voltages as high as 18V. They are available with several fixed output voltages ranging from 2.1V to 6.0V. CMOS technology ensures low voltage drop and low quiescent current. Although designed primarily as fixed voltage regulators, these devices can be used with external components to obtain variable voltages and currents.

Selection Table

Part No.	Output Voltage	Package
HE6521Mxx	2.1V	SOT89 SOT23
HE6523Mxx	2.3V	
HE6525Mxx	2.5V	
HE6527Mxx	2.7V	
HE6530Mxx	3.0V	
HE6533Mxx	3.3V	
HE6536Mxx	3.6V	
HE6540Mxx	4.0V	
HE6544Mxx	4.4V	
HE6545Mxx	4.5V	
HE6550Mxx	5.0V	

Note: "XX" stands for output voltages.

Order Information

HE65①②③④⑤

Designator	Symbol	Description
① ②	Integer	Output Voltage(2.1~5.0V)
③	M	Standard
④	P	Package:SOT89
	N	Package:SOT23
⑤	R	RoHS / Pb Free
	G	Halogen Free

Block Diagram

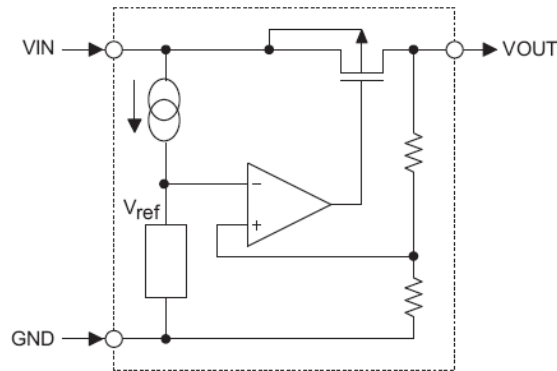

Pin Assignment

SOT23 (Top View)

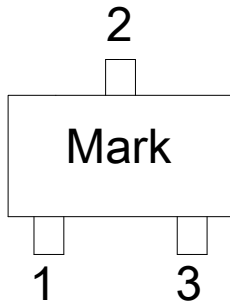

Table1: HE65XXMNR series (SOT23 PKG)

PIN NO.	PIN NAME	FUNCTION
1	GND	GND pin
2	VIN	Input voltage pin
3	VOUT	Output voltage pin

SOT89 (Top View)

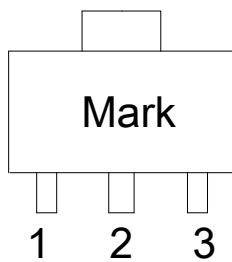

Table2: HE65XXMPR series (SOT89 PKG)

PIN NO.	PIN NAME	FUNCTION
1	VOUT	Output voltage pin
2	VIN	Input voltage pin
3	GND	GND pin

Absolute Maximum Ratings

Supply Voltage-0.3V to 18V

Storage Temperature-50°C to 125°C

Operating Temperature-40°C to 85°C

Note: These are stress ratings only. Stresses exceeding the range specified under “Absolute Maximum Ratings” may cause substantial damage to the device. Functional operation of this device at other conditions beyond those listed in the specification is not implied and prolonged exposure to extreme conditions may affect device reliability.

Thermal Information

Symbol	Parameter	Package	Max.	Unit
θ_{JA}	Thermal Resistance (Junction to Ambient) (Assume no ambient airflow, no heat sink)	SOT89	200	$^{\circ}\text{C}/\text{W}$
		SOT23	500	$^{\circ}\text{C}/\text{W}$
P_D	Power Dissipation	SOT89	0.50	W
		SOT23	0.20	W

Note: P_D is measured at $T_a = 25^{\circ}\text{C}$

Electrical Characteristics

HE6521Mxx, +2.1V Output Type

Symbol	Parameter	Test Conditions		Min.	Typ.	Max.	Unit
		V_{IN}	Conditions				
V_{OUT}	Output Voltage	4.1V	$I_{OUT}=10\text{mA}$	2.058	2.100	2.142	V
I_{OUT}	Output Current	4.1V	-	120	150	-	mA
ΔV_{OUT}	Load Regulation	4.1V	$1\text{mA} \leq I_{OUT} \leq 50\text{mA}$	-	60	150	mV
V_{DIF}	Voltage Drop(Note)	-	$I_{OUT}=1\text{mA}, \Delta V_{OUT}=2\%$	-	50	-	mV
I_{SS}	Current Consumption	4.1V	No load	-	1.5	2	μA
$\frac{\Delta V_{OUT}}{\Delta V_{IN} \times V_{OUT}}$	Line Regulation	-	$3.1\text{V} \leq V_{IN} \leq 16\text{V}$ $I_{OUT}=1\text{mA}$	-	0.2	-	%/V
V_{IN}	Input Voltage	-	-	-	-	15	V
$\frac{\Delta V_{OUT}}{\Delta T_a}$	Temperature Coefficient	4.1V	$I_{OUT}=10\text{mA}$ $0^{\circ}\text{C} < T_a < 70^{\circ}\text{C}$	-	± 0.37	-	$\text{mV}/^{\circ}\text{C}$

Note: Dropout voltage is defined as the input voltage minus the output voltage that produces a 2% change in the output voltage from the value at $V_{IN} = V_{OUT} + 2\text{V}$ with a fixed load.

HE6523Mxx, +2.3V Output Type

Symbol	Parameter	Test Conditions		Min.	Typ.	Max.	Unit
		V _{IN}	Conditions				
V _{OUT}	Output Voltage	4.3V	I _{OUT} =10mA	2.254	2.300	2.346	V
I _{OUT}	Output Current	4.3V	-	120	150	-	mA
Δ V _{OUT}	Load Regulation	4.3V	1mA ≤ I _{OUT} ≤ 50mA	-	60	150	mV
V _{DIF}	Voltage Drop(Note)	-	I _{OUT} =1mA, Δ V _{OUT} =2%	-	50	-	mV
I _{SS}	Current Consumption	4.3V	No load	-	1.5	2	μ A
$\frac{\Delta V_{OUT}}{\Delta V_{IN} \times V_{OUT}}$	Line Regulation	-	3.3V ≤ V _{IN} ≤ 16V I _{OUT} =1mA	-	0.2	-	%/V
V _{IN}	Input Voltage	-	-	-	-	15	V
$\frac{\Delta V_{OUT}}{\Delta T_a}$	Temperature Coefficient	4.3V	I _{OUT} =10mA 0°C < T _a < 70°C	-	±0.39	-	mV/°C

Note: Dropout voltage is defined as the input voltage minus the output voltage that produces a 2% change in the output voltage from the value at V_{IN} = V_{OUT}+2V with a fixed load.

HE6525Mxx, +2.5V Output Type

Symbol	Parameter	Test Conditions		Min.	Typ.	Max.	Unit
		V _{IN}	Conditions				
V _{OUT}	Output Voltage	4.5V	I _{OUT} =10mA	2.45	2.500	2.55	V
I _{OUT}	Output Current	4.5V	-	120	150	-	mA
Δ V _{OUT}	Load Regulation	4.5V	1mA ≤ I _{OUT} ≤ 50mA	-	60	150	mV
V _{DIF}	Voltage Drop(Note)	-	I _{OUT} =1mA, Δ V _{OUT} =2%	-	50	-	mV
I _{SS}	Current Consumption	4.5V	No load	-	1.5	2	μ A
$\frac{\Delta V_{OUT}}{\Delta V_{IN} \times V_{OUT}}$	Line Regulation	-	3.5V ≤ V _{IN} ≤ 16V I _{OUT} =1mA	-	0.2	-	%/V
V _{IN}	Input Voltage	-	-	-	-	15	V
$\frac{\Delta V_{OUT}}{\Delta T_a}$	Temperature Coefficient	4.5V	I _{OUT} =10mA 0°C < T _a < 70°C	-	±0.41	-	mV/°C

Note: Dropout voltage is defined as the input voltage minus the output voltage that produces a 2% change in the output voltage from the value at V_{IN} = V_{OUT}+2V with a fixed load.

HE6527Mxx, +2.7V Output Type

Symbol	Parameter	Test Conditions		Min.	Typ.	Max.	Unit
		V _{IN}	Conditions				
V _{OUT}	Output Voltage	4.7V	I _{OUT} =10mA	2.646	2.700	2.754	V
I _{OUT}	Output Current	4.7V	-	120	150	-	mA
Δ V _{OUT}	Load Regulation	4.7V	1mA ≤ I _{OUT} ≤ 50mA	-	60	150	mV
V _{DIF}	Voltage Drop(Note)	-	I _{OUT} =1mA, Δ V _{OUT} =2%	-	50	-	mV
I _{SS}	Current Consumption	4.7V	No load	-	1.5	2	μ A
$\frac{\Delta V_{OUT}}{\Delta V_{IN} \times V_{OUT}}$	Line Regulation	-	3.7V ≤ V _{IN} ≤ 16V I _{OUT} =1mA	-	0.2	-	%/V
V _{IN}	Input Voltage	-	-	-	-	15	V
$\frac{\Delta V_{OUT}}{\Delta T_a}$	Temperature Coefficient	4.7V	I _{OUT} =10mA 0°C < T _a < 70°C	-	±0.43	-	mV/°C

Note: Dropout voltage is defined as the input voltage minus the output voltage that produces a 2% change in the output voltage from the value at V_{IN} = V_{OUT}+2V with a fixed load.

HE6530Mxx, +3.0V Output Type

Symbol	Parameter	Test Conditions		Min.	Typ.	Max.	Unit
		V _{IN}	Conditions				
V _{OUT}	Output Voltage	5V	I _{OUT} =10mA	2.94	3.00	3.06	V
I _{OUT}	Output Current	5V	-	120	150	-	mA
Δ V _{OUT}	Load Regulation	5V	1mA ≤ I _{OUT} ≤ 50mA	-	60	150	mV
V _{DIF}	Voltage Drop(Note)	-	I _{OUT} =1mA, Δ V _{OUT} =2%	-	50	-	mV
I _{SS}	Current Consumption	5V	No load	-	1.5	2	μ A
$\frac{\Delta V_{OUT}}{\Delta V_{IN} \times V_{OUT}}$	Line Regulation	-	4V ≤ V _{IN} ≤ 16V I _{OUT} =1mA	-	0.2	-	%/V
V _{IN}	Input Voltage	-	-	-	-	15	V
$\frac{\Delta V_{OUT}}{\Delta T_a}$	Temperature Coefficient	5V	I _{OUT} =10mA 0°C < T _a < 70°C	-	±0.45	-	mV/°C

Note: Dropout voltage is defined as the input voltage minus the output voltage that produces a 2% change in the output voltage from the value at V_{IN} = V_{OUT}+2V with a fixed load.

HE6533Mxx, +3.3V Output Type

Symbol	Parameter	Test Conditions		Min.	Typ.	Max.	Unit
		V _{IN}	Conditions				
V _{OUT}	Output Voltage	5.3V	I _{OUT} =10mA	3.234	3.300	3.366	V
I _{OUT}	Output Current	5.3V	-	120	150	-	mA
Δ V _{OUT}	Load Regulation	5.3V	1mA ≤ I _{OUT} ≤ 50mA	-	60	150	mV
V _{DIF}	Voltage Drop(Note)	-	I _{OUT} =1mA, Δ V _{OUT} =2%	-	50	-	mV
I _{SS}	Current Consumption	5.3V	No load	-	1.5	2	μ A
$\frac{\Delta V_{OUT}}{\Delta V_{IN} \times V_{OUT}}$	Line Regulation	-	4.5V ≤ V _{IN} ≤ 16V I _{OUT} =1mA	-	0.2	-	%/V
V _{IN}	Input Voltage	-	-	-	-	15	V
$\frac{\Delta V_{OUT}}{\Delta T_a}$	Temperature Coefficient	5.3V	I _{OUT} =10mA 0°C < T _a < 70°C	-	±0.5	-	mV/°C

Note: Dropout voltage is defined as the input voltage minus the output voltage that produces a 2% change in the output voltage from the value at V_{IN} = V_{OUT}+2V with a fixed load.

HE6536Mxx, +3.6V Output Type

Symbol	Parameter	Test Conditions		Min.	Typ.	Max.	Unit
		V _{IN}	Conditions				
V _{OUT}	Output Voltage	5.6V	I _{OUT} =10mA	3.528	3.600	3.672	V
I _{OUT}	Output Current	5.6V	-	120	150	-	mA
Δ V _{OUT}	Load Regulation	5.6V	1mA ≤ I _{OUT} ≤ 50mA	-	60	150	mV
V _{DIF}	Voltage Drop(Note)	-	I _{OUT} =1mA, Δ V _{OUT} =2%	-	50	-	mV
I _{SS}	Current Consumption	5.6V	No load	-	1.5	2.0	μ A
$\frac{\Delta V_{OUT}}{\Delta V_{IN} \times V_{OUT}}$	Line Regulation	-	4.6V ≤ V _{IN} ≤ 16V I _{OUT} =1mA	-	0.2	-	%/V
V _{IN}	Input Voltage	-	-	-	-	15	V
$\frac{\Delta V_{OUT}}{\Delta T_a}$	Temperature Coefficient	5.6V	I _{OUT} =10mA 0°C < T _a < 70°C	-	±0.6	-	mV/°C

Note: Dropout voltage is defined as the input voltage minus the output voltage that produces a 2% change in the output voltage from the value at V_{IN} = V_{OUT}+2V with a fixed load.

HE6540Mxx, +4.0V Output Type

Symbol	Parameter	Test Conditions		Min.	Typ.	Max.	Unit
		V _{IN}	Conditions				
V _{OUT}	Output Voltage	6.0V	I _{OUT} =10mA	3.920	4.000	4.080	V
I _{OUT}	Output Current	6.0V	-	120	150	-	mA
Δ V _{OUT}	Load Regulation	6.0V	1mA ≤ I _{OUT} ≤ 50mA	-	60	150	mV
V _{DIF}	Voltage Drop(Note)	-	I _{OUT} =1mA, Δ V _{OUT} =2%	-	50	-	mV
I _{SS}	Current Consumption	6.0V	No load	-	1.5	2.0	μ A
$\frac{\Delta V_{OUT}}{\Delta V_{IN} \times V_{OUT}}$	Line Regulation	-	5V ≤ V _{IN} ≤ 16V I _{OUT} =1mA	-	0.2	-	%/V
V _{IN}	Input Voltage	-	-	-	-	15	V
$\frac{\Delta V_{OUT}}{\Delta T_a}$	Temperature Coefficient	6.0V	I _{OUT} =10mA 0°C < T _a < 70°C	-	±0.6	-	mV/°C

Note: Dropout voltage is defined as the input voltage minus the output voltage that produces a 2% change in the output voltage from the value at V_{IN} = V_{OUT}+2V with a fixed load.

HE6544Mxx, +4.4V Output Type

Symbol	Parameter	Test Conditions		Min.	Typ.	Max.	Unit
		V _{IN}	Conditions				
V _{OUT}	Output Voltage	6.4V	I _{OUT} =10mA	4.312	4.400	4.488	V
I _{OUT}	Output Current	6.4V	-	120	150	-	mA
Δ V _{OUT}	Load Regulation	6.4V	1mA ≤ I _{OUT} ≤ 50mA	-	60	150	mV
V _{DIF}	Voltage Drop(Note)	-	I _{OUT} =1mA, Δ V _{OUT} =2%	-	50	-	mV
I _{SS}	Current Consumption	6.4V	No load	-	1.5	2.0	μ A
$\frac{\Delta V_{OUT}}{\Delta V_{IN} \times V_{OUT}}$	Line Regulation	-	5.4V ≤ V _{IN} ≤ 16V I _{OUT} =1mA	-	0.2	-	%/V
V _{IN}	Input Voltage	-	-	-	-	15	V
$\frac{\Delta V_{OUT}}{\Delta T_a}$	Temperature Coefficient	6.4V	I _{OUT} =10mA 0°C < T _a < 70°C	-	±0.7	-	mV/°C

Note: Dropout voltage is defined as the input voltage minus the output voltage that produces a 2% change in the output voltage from the value at V_{IN} = V_{OUT}+2V with a fixed load.

HE6545Mxx, +4.5V Output Type

Symbol	Parameter	Test Conditions		Min.	Typ.	Max.	Unit
		V _{IN}	Conditions				
V _{OUT}	Output Voltage	6.5V	I _{OUT} =10mA	4.410	4.500	4.590	V
I _{OUT}	Output Current	6.5V	-	120	150	-	mA
Δ V _{OUT}	Load Regulation	6.5V	1mA ≤ I _{OUT} ≤ 50mA	-	60	150	mV
V _{DIF}	Voltage Drop(Note)	-	I _{OUT} =1mA, Δ V _{OUT} =2%	-	50	-	mV
I _{SS}	Current Consumption	6.5V	No load	-	1.5	2.0	μ A
$\frac{\Delta V_{OUT}}{\Delta V_{IN} \times V_{OUT}}$	Line Regulation	-	5.5V ≤ V _{IN} ≤ 16V I _{OUT} =1mA	-	0.2	-	%/V
V _{IN}	Input Voltage	-	-	-	-	15	V
$\frac{\Delta V_{OUT}}{\Delta T_a}$	Temperature Coefficient	6.5V	I _{OUT} =10mA 0°C < T _a < 70°C	-	±0.7	-	mV/°C

Note: Dropout voltage is defined as the input voltage minus the output voltage that produces a 2% change in the output voltage from the value at V_{IN} = V_{OUT}+2V with a fixed load.

HE6550Mxx, +5.0V Output Type

Symbol	Parameter	Test Conditions		Min.	Typ.	Max.	Unit
		V _{IN}	Conditions				
V _{OUT}	Output Voltage	7V	I _{OUT} =10mA	4.9	5.00	5.1	V
I _{OUT}	Output Current	7V	-	120	150	-	mA
Δ V _{OUT}	Load Regulation	7V	1mA ≤ I _{OUT} ≤ 50mA	-	60	150	mV
V _{DIF}	Voltage Drop(Note)	-	I _{OUT} =1mA, Δ V _{OUT} =2%	-	50	-	mV
I _{SS}	Current Consumption	7V	No load	-	1.5	2.0	μ A
$\frac{\Delta V_{OUT}}{\Delta V_{IN} \times V_{OUT}}$	Line Regulation	-	6V ≤ V _{IN} ≤ 16V I _{OUT} =1mA	-	0.2	-	%/V
V _{IN}	Input Voltage	-	-	-	-	15	V
$\frac{\Delta V_{OUT}}{\Delta T_a}$	Temperature Coefficient	7V	I _{OUT} =10mA 0°C < T _a < 70°C	-	±0.75	-	mV/°C

Note: Dropout voltage is defined as the input voltage minus the output voltage that produces a 2% change in the output voltage from the value at V_{IN} = V_{OUT}+2V with a fixed load.

Typical Performance Characteristics

(1) Output Voltage vs Input voltage

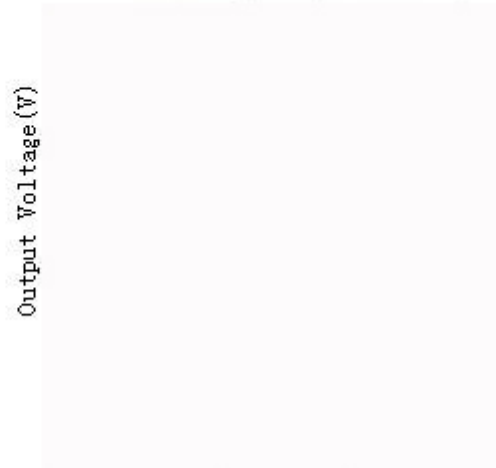
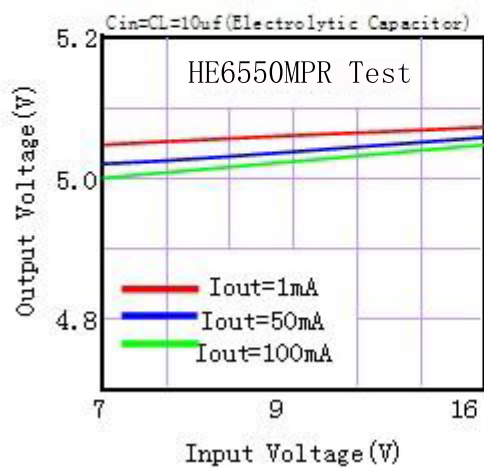
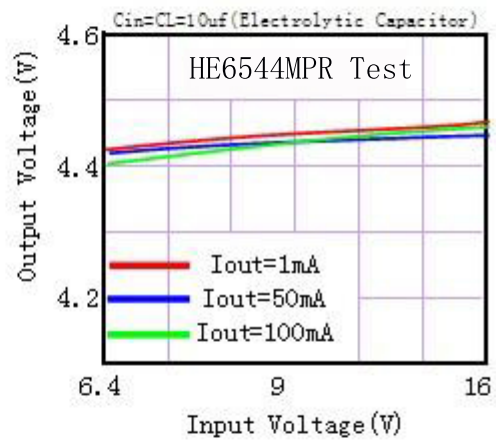
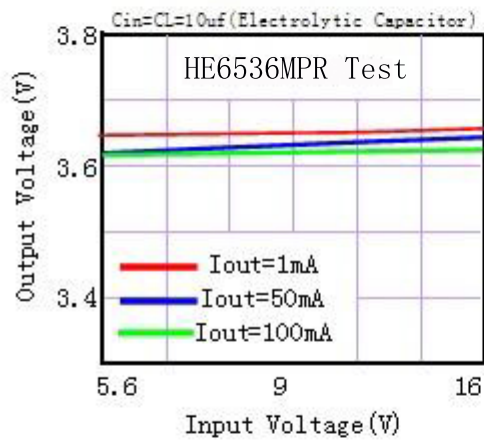
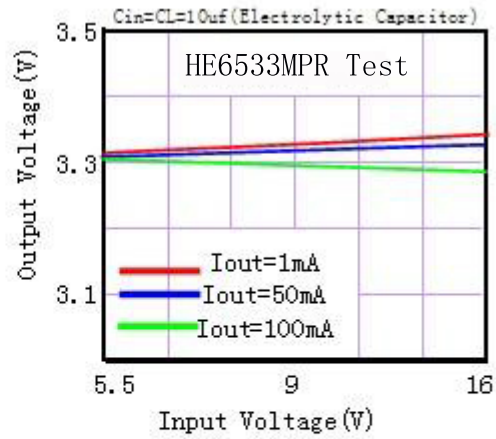
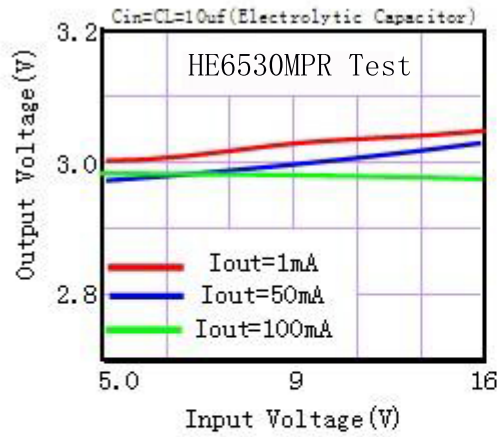

(2) Output Voltage vs. Output Current

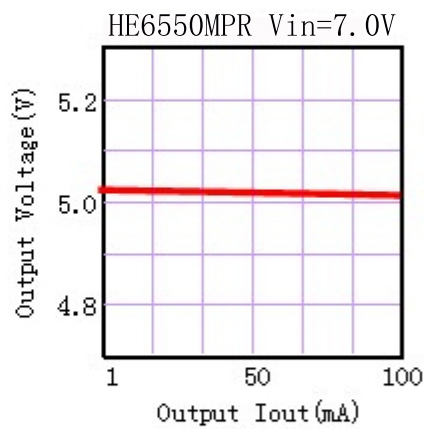
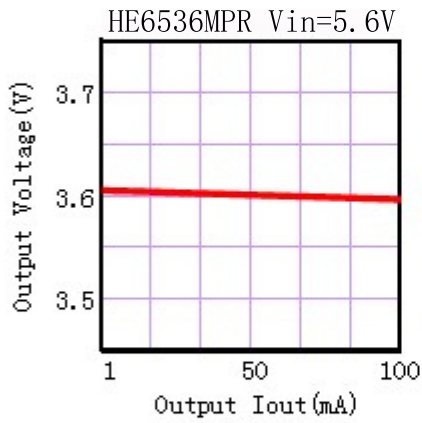
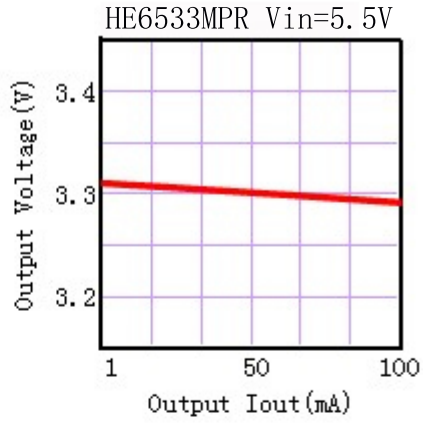
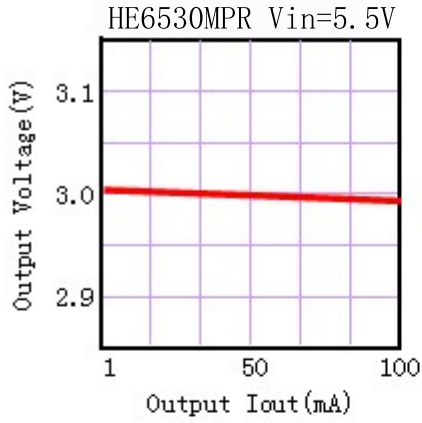

(3) Input Transient Response

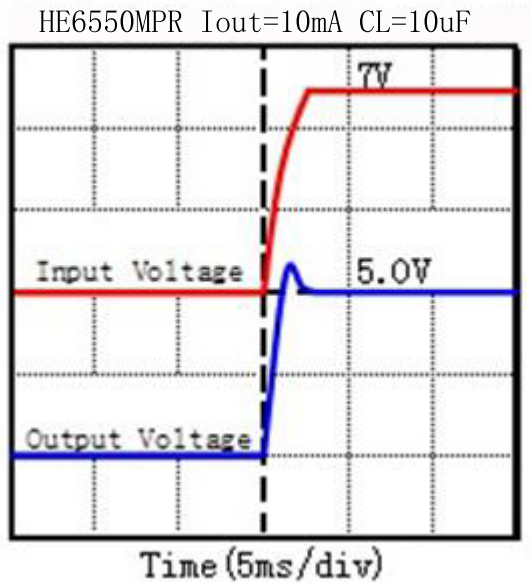

(4) Output Voltage vs. Ambient Temperature

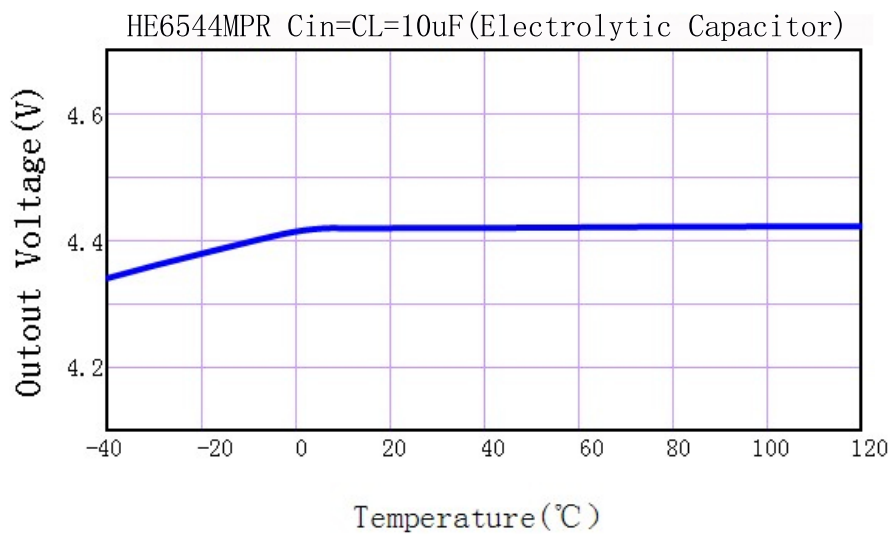

(5) MAX Output Current Vs. Input Voltage

HE6530MPR

Input Voltage	Max Output Current
5V	150mA
9V	150mA
12V	100mA
16V	60mA

HE6533MPR

Input Voltage	Max Output Current
5.3V	150mA
9V	150mA
12V	150mA
16V	100mA

HE6550MPR

Input Voltage	Max Output Current
7V	150mA
9V	150mA
12V	150mA
16V	100mA

Application Circuits

Basic Circuits

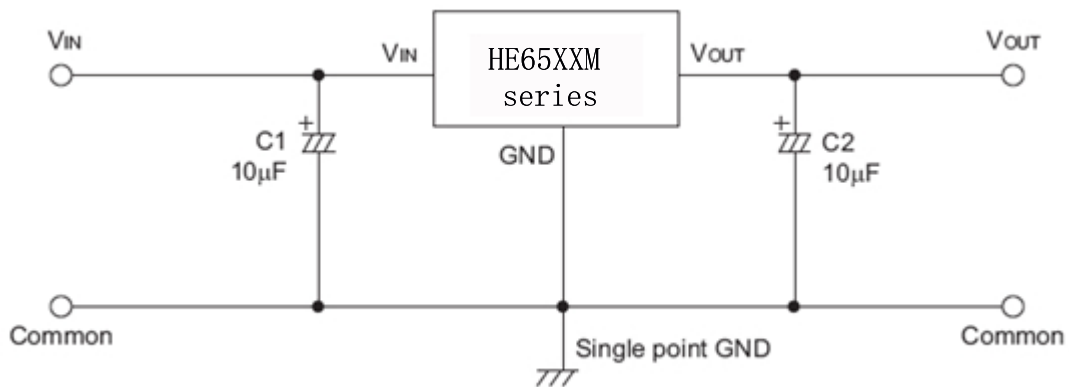

High Output Current Positive Voltage Regulator

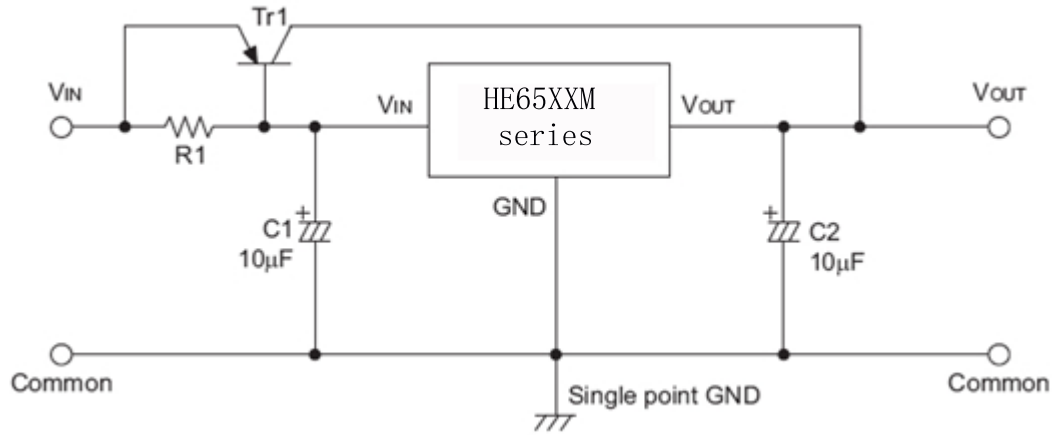

Short-Circuit Protection by $Tr1$

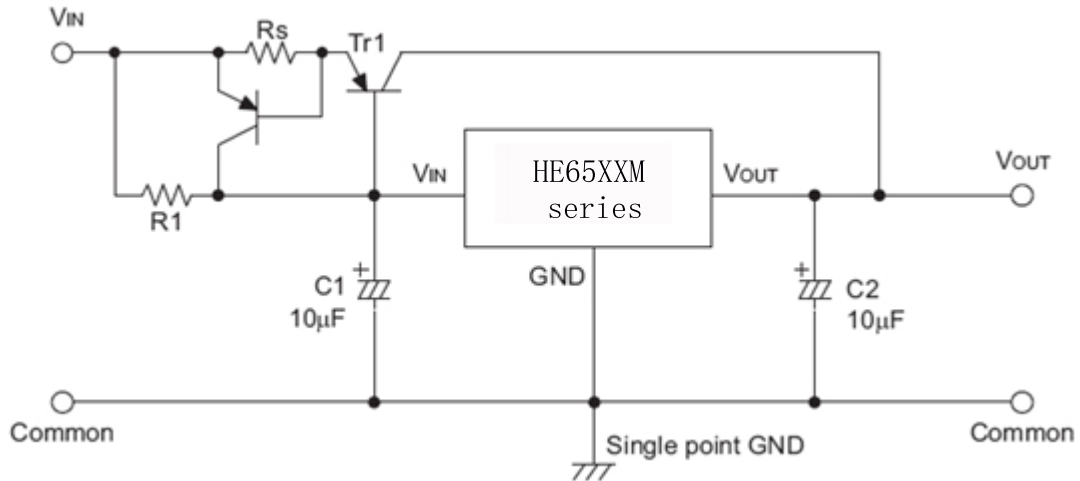

Circuit for Increasing Output Voltage

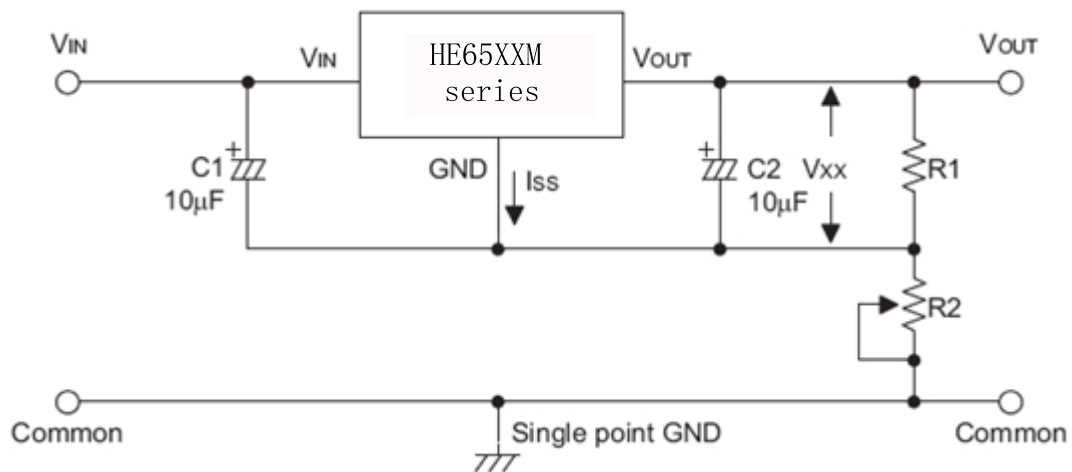

Circuit for Increasing Output Voltage

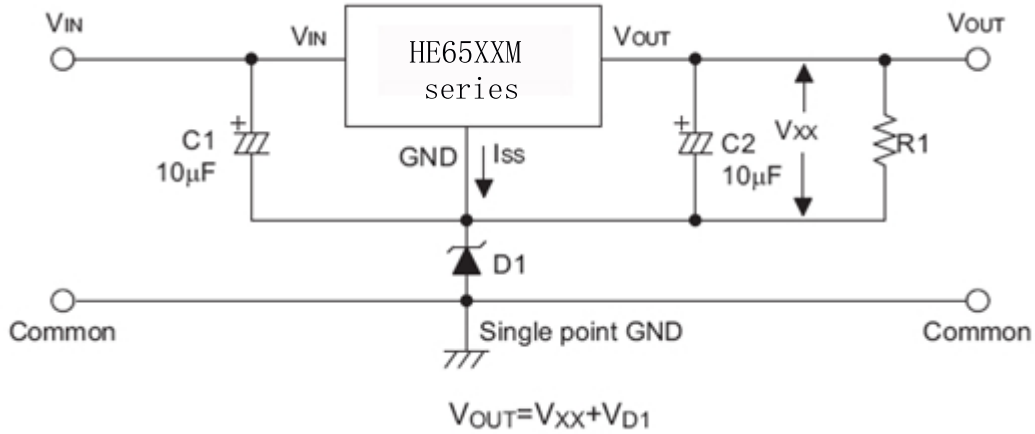

Constant Current Regulator

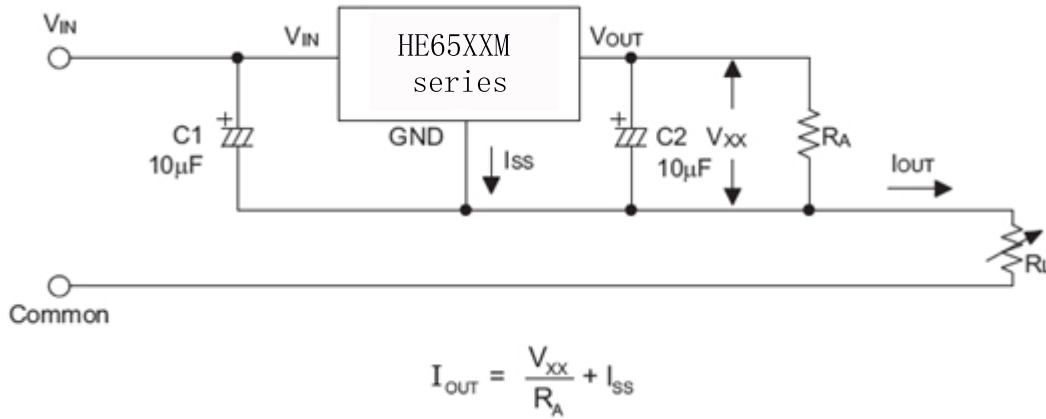

Dual Supply

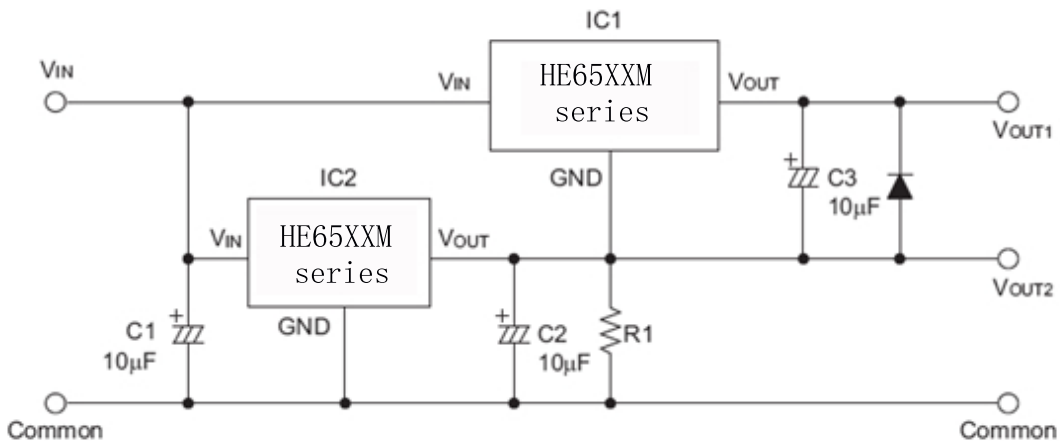

Package Information

3-pin SOT89 Outline Dimensions

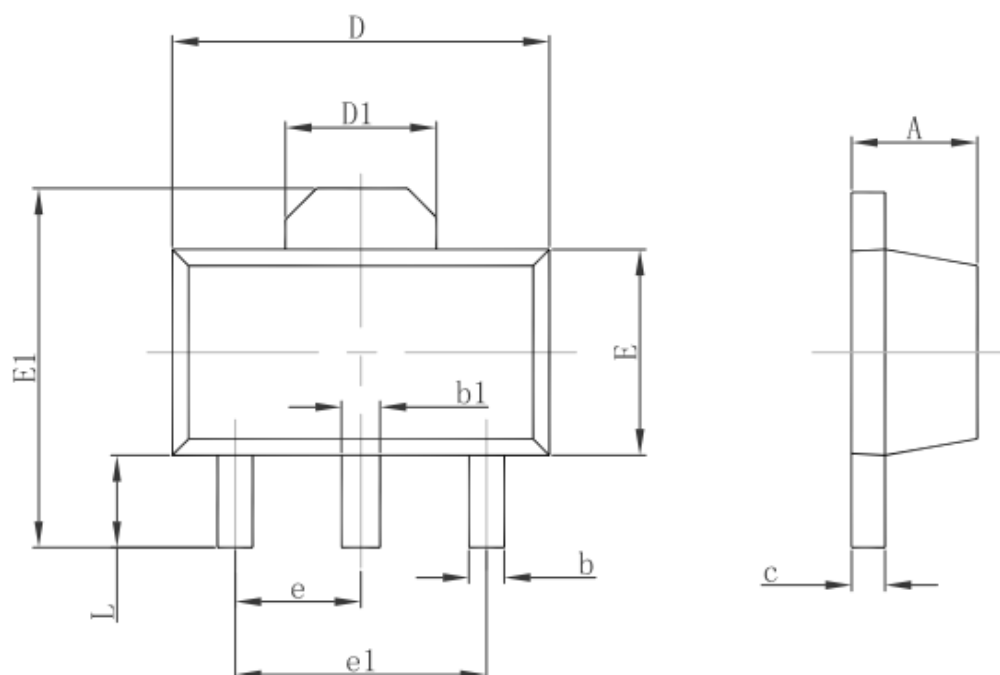

Symbol	Dimensions In Millimeters		Dimensions In Inches	
	Min.	Max.	Min.	Max.
A	1.400	1.600	0.055	0.063
b	0.320	0.520	0.013	0.020
b1	0.400	0.580	0.016	0.023
c	0.350	0.440	0.014	0.017
D	4.400	4.600	0.173	0.181
D1	1.550 REF.		0.061 REF.	
E	2.300	2.600	0.091	0.102
E1	3.940	4.250	0.155	0.167
e	1.500 TYP.		0.060 TYP.	
e1	3.000 TYP.		0.118 TYP.	
L	0.900	1.200	0.035	0.047

3-pin SOT23 Outline Dimensions

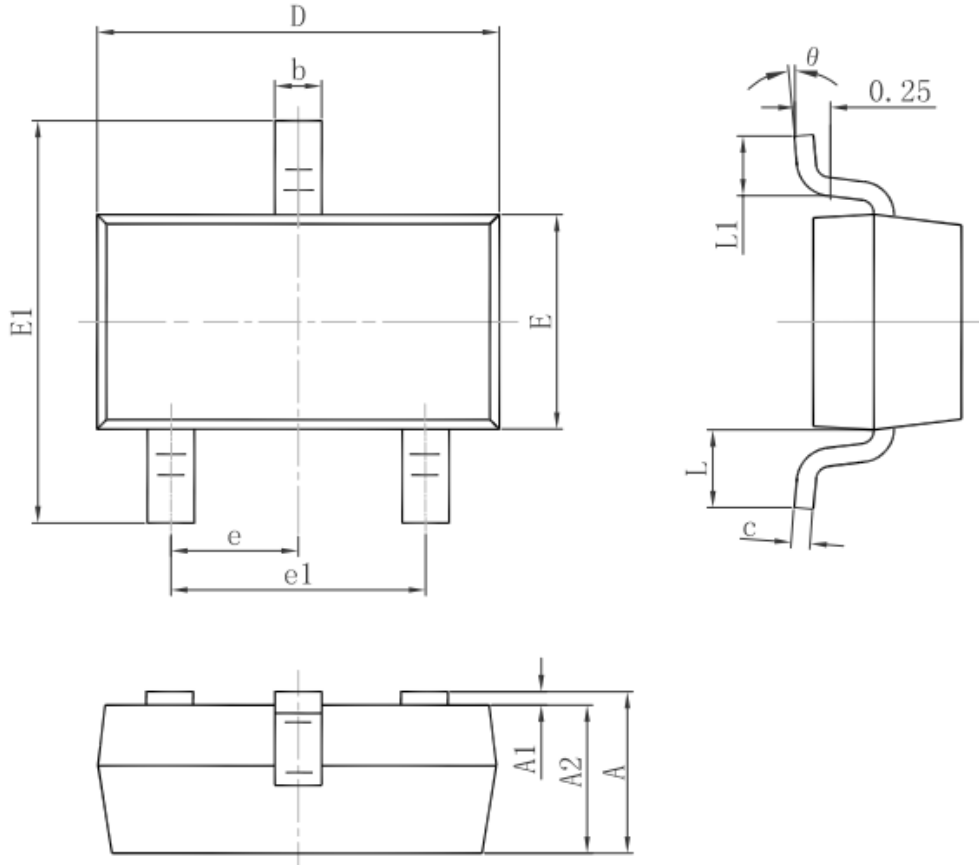

Symbol	Dimensions In Millimeters		Dimensions In Inches	
	Min.	Max.	Min.	Max.
A	0.900	1.150	0.035	0.045
A1	0.000	0.100	0.000	0.004
A2	0.900	1.050	0.035	0.041
b	0.300	0.500	0.012	0.020
c	0.080	0.150	0.003	0.006
D	2.800	3.000	0.110	0.118
E	1.200	1.400	0.047	0.055
E1	2.250	2.550	0.089	0.100
e	0.950 TYP.		0.037 TYP.	
e1	1.800	2.000	0.071	0.079
L	0.550 REF.		0.022 REF.	
L1	0.300	0.500	0.012	0.020
θ	0°	8°	0°	8°

X-ON Electronics

Largest Supplier of Electrical and Electronic Components

Click to view similar products for [Linear Voltage Regulators](#) category:

Click to view products by [HEERMICR](#) manufacturer:

Other Similar products are found below :

[LV56831P-E](#) [LV5684PVD-XH](#) [MCDTSA6-2R](#) [L7815ACV-DG](#) [PQ3DZ53U](#) [LV56801P-E](#) [TLE42794G](#) [L78L05CZ/1SX](#) [L78LR05DL-MA-E](#) [636416C](#) [714954EB](#) [BA033LBSG2-TR](#) [LV5680P-E](#) [L78M15CV-DG](#) [TLS202B1MBV33HTSA1](#) [L79M05T-E](#) [TLS202A1MBVHTSA1](#) [L78LR05D-MA-E](#) [NCV317MBTG](#) [NTE7227](#) [LV5680NPVC-XH](#) [LT1054CN8](#) [MP2018GZD-5-Z](#) [MP2018GZD-33-Z](#) [MIC5281-3.3YMM](#) [RT9078-28GQZ](#) [MC78L06BP-AP](#) [TA48LS05F\(TE85L,F\)](#) [TA78L12F\(TE12L,F\)](#) [TC47BR5003ECT](#) [TCR2LN12,LF\(S](#) [TCR2LN28,LF\(S](#) [TCR2LN30,LF\(S](#) [TCR3DF295,LM\(CT](#) [TCR3DF40,LM\(CT](#) [BA178M20CP-E2](#) [L78M12ABDT](#) [LM7812SX/NOPB](#) [LR645N3-G-P003](#) [LR645N3-G-P013](#) [ZXTR2005P5-13](#) [SCD7812BTG](#) [TCR3DF335,LM\(CT](#) [ZXTR2012K-13](#) [TLE42994E V33](#) [ZXTR2008K-13](#) [ZXTR2005K-13](#) [LA5693D-E](#) [L88R05DL-E](#) [ADP3300ARTZ-2.7RL7](#)