

**CONFIGURATION 1 SHOWN  
PRODUCT SHIPPED IN CLAMP OPEN POSITION**

Revision level			Revision Record	Changed	Date	Approved	Date
Drawing	State	Part					
10.1	Design Release	B	SEE ECN# 015124	CTF	05/07/2019	MHT	05/07/2019

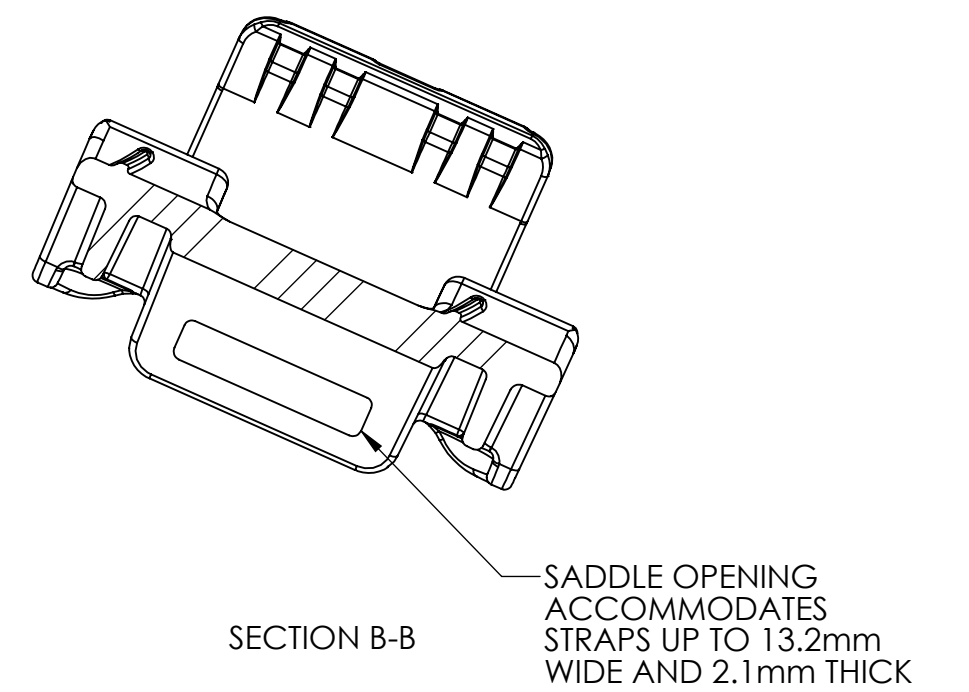
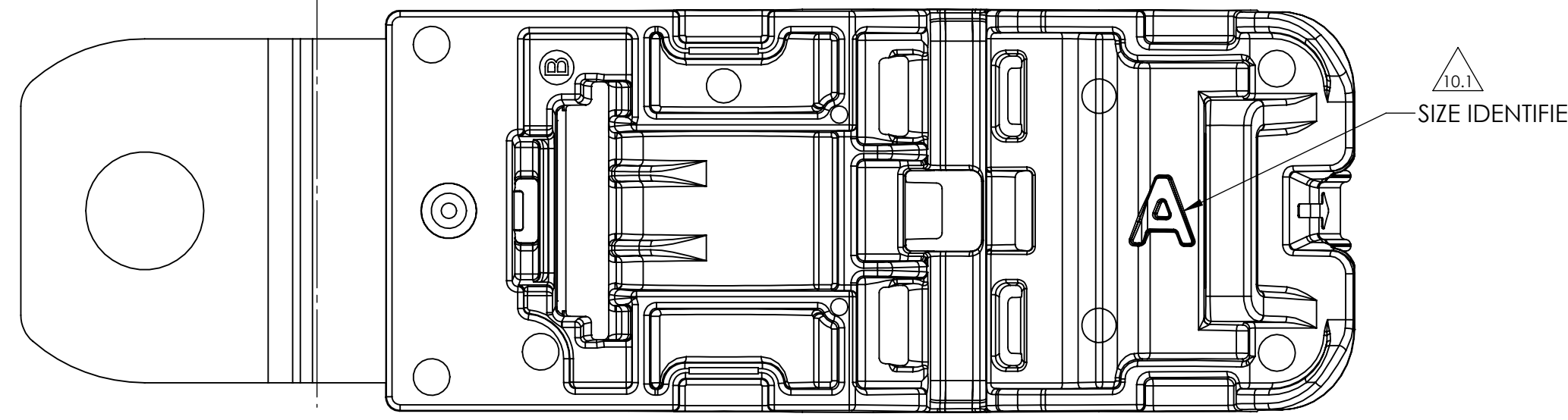
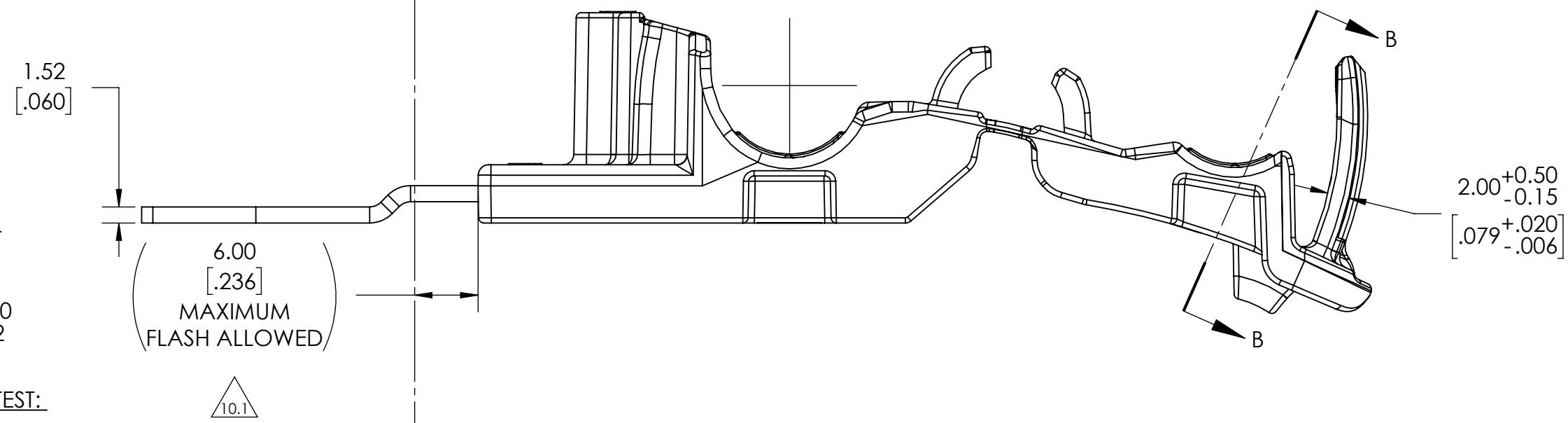
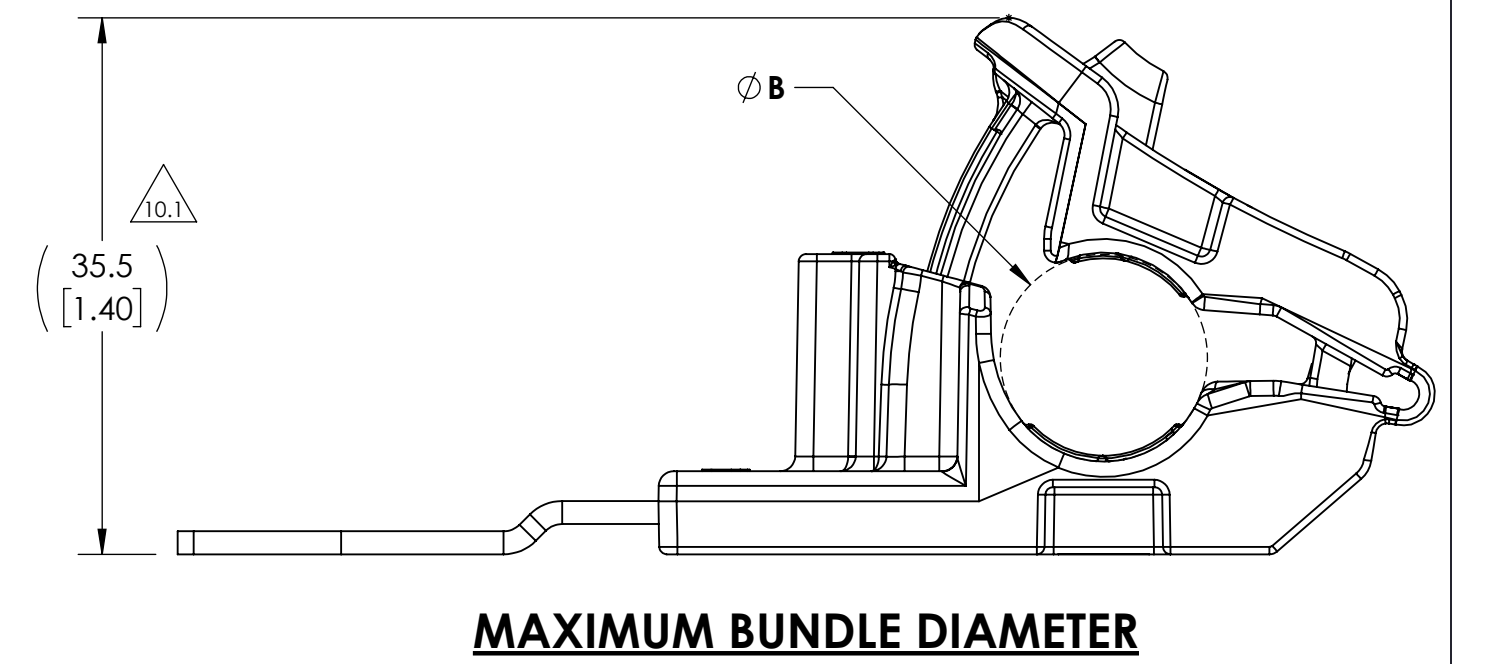
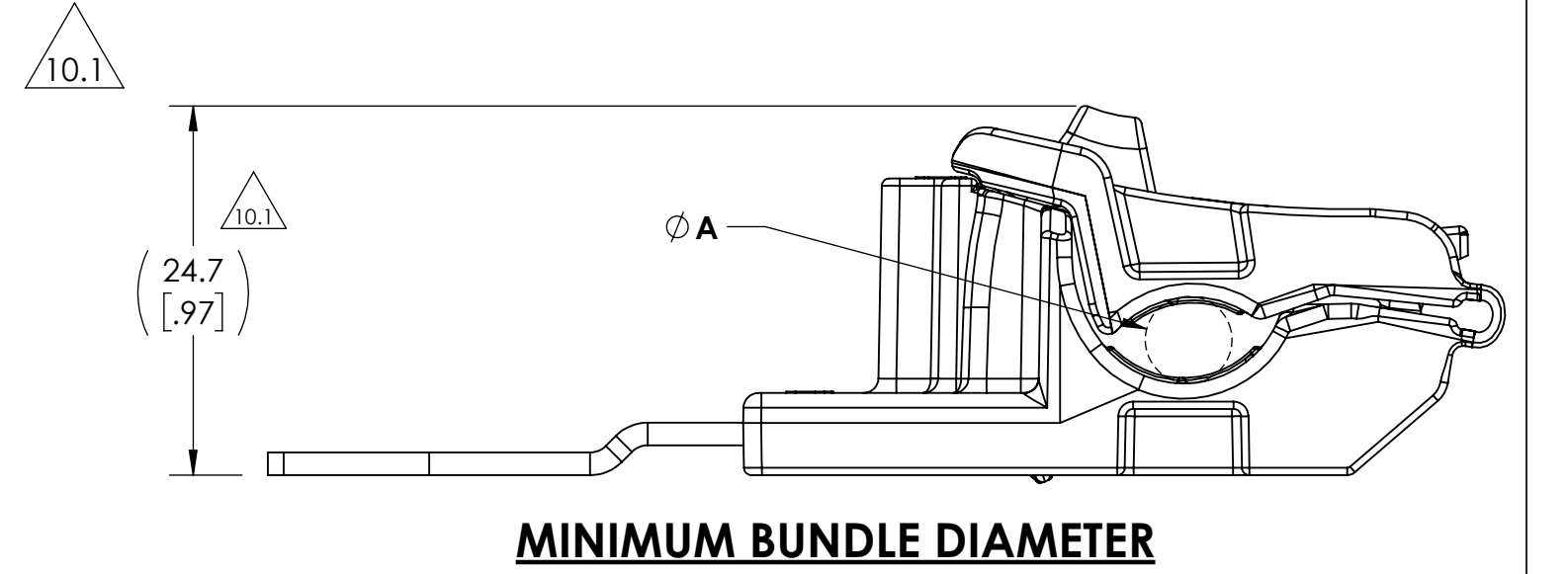
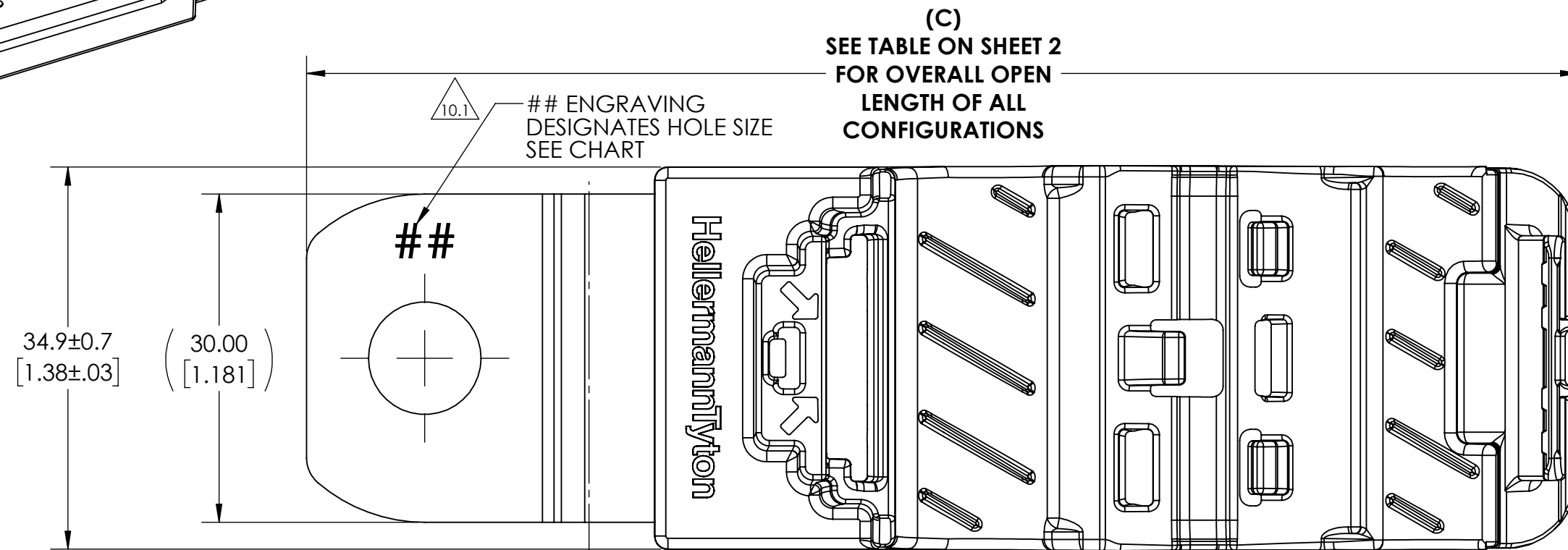

- INITIAL MOLD VALIDATION:**  
DRY AS MOLDED WITH ≤ 0.5% MOISTURE CONTENT:
- ITS-0003 RATCHET CLAMP SOLID MANDREL TEST: EXCEEDED 445 NEWTONS (100 LBS) MIN AT A NOMINAL BUNDLE DIAMETER OF 9.53 [0.375] TESTING ONLY REQUIRED OF CONFIGURATION \*RCA180SM10, \*RCA180LM10, AND \*RCA90LM10 \*TESTING CAN BE SUBSTITUTED WITH M6, M8, M12 VERSION MOUNTING HOLES
  - ITS-0008 RATCHET CLAMP CLOSE AND RELEASE TEST: EXCEEDED 445 NEWTONS (100 LBS) MIN AT A NOMINAL BUNDLE DIAMETER OF 9.53 [0.375] AFTER CLOSING AND RELEASING 40 TIMES
  - ITS-0014 RATCHET CLAMP LOW TEMPERATURE HINGE TEST: NO DAMAGE OCCURED AFTER BENDING LIVING HINGE 40 TIMES AT -40°C

- PERFORMANCE REQUIREMENTS:**  
DRY AS MOLDED WITH ≤ 0.5% MOISTURE CONTENT:
- ITS-0001 RATCHET CLAMP SPLIT MANDREL TEST: 445 NEWTONS (100 LBS) MIN AT A NOMINAL BUNDLE DIAMETER OF 9.53 [0.375]
  - MAXIMUM PERCENT REGRIND PERMISSABLE: 25%
  - MAXIMUM ALLOWABLE FLASH OR MISMATCH TO BE: 0.25mm

NOTE: TESTING #2, #3 AND #4 CAN BE DONE ON ANY TYPE NUMBER AND WILL APPLY TO ALL OTHER TYPE NUMBERS IN THE TABLE ON SHEET 2

BUNDLE TYPES	A MINIMUM DIAMETER	B MAXIMUM DIAMETER
SOFT	6.2 [.24]	13.7 [.54]
HARD	5.4 [.21]	12.9 [.51]

Notes	Material 1. PA66HIRHSUV 2. ZINC PLATED STEEL	Units: millimeters Dimension without tolerances details to: .xxx = ±.013 .xx = ±.13 .x = ±.3 None = ±.8 < = ±0.5*	The copyright of this drawing is reserved by HellermannTyton. It is issued on condition that it is not reproduced, copied, or disclosed to a third party, either wholly or in part, without the consent of HellermannTyton.	Drawn	MHT	05/26/2015	Article/Type-No SEE CHART SHEET 2	Scale 2:1
				Approved	KAC	05/28/2015		
				HellermannTyton North America Email: corp@htamericas.com Web: www.hellermann.tyton.com			Drawing-No <b>15-0341-102-CSU</b>	Production: Phase Format C Sheet 1/2

Revision level			Revision Record	Changed	Date	Approved	Date
Drawing	State	Part					
10.1	Design Release	B	SEE ECN# 015124	CTF	05/07/2019	MHT	05/07/2019

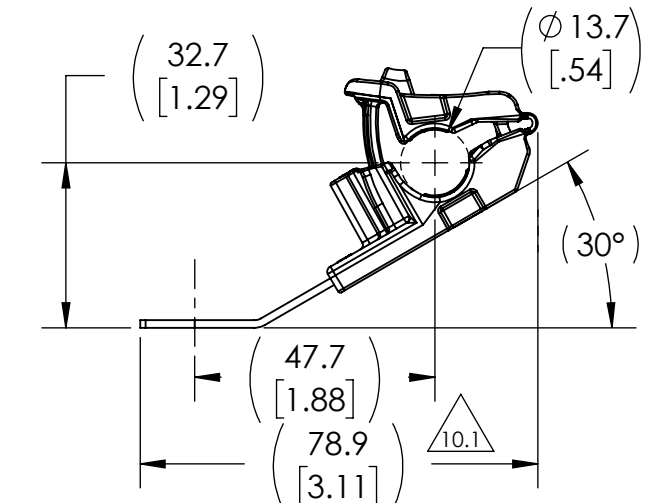
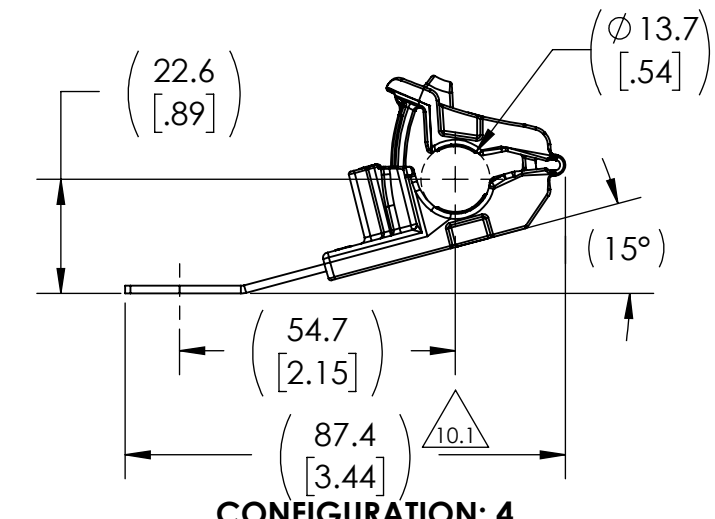
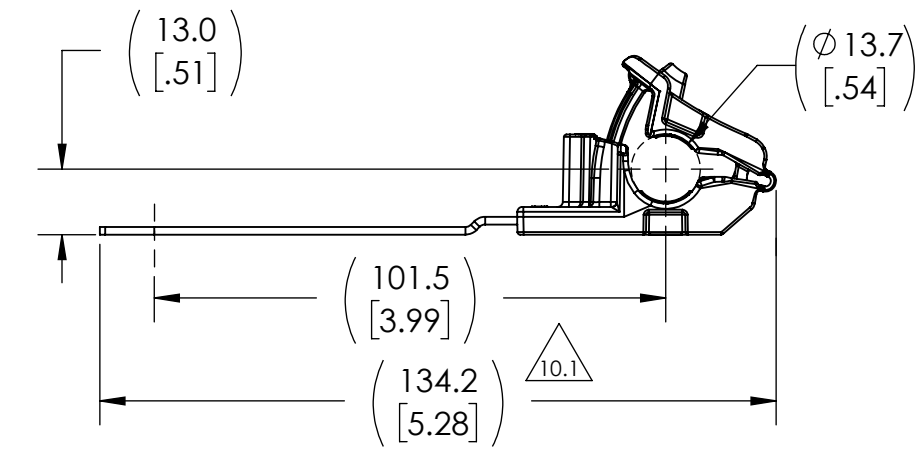
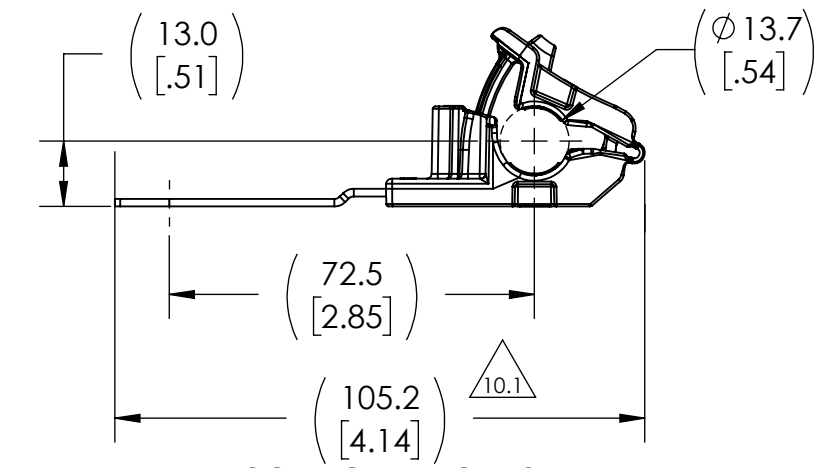
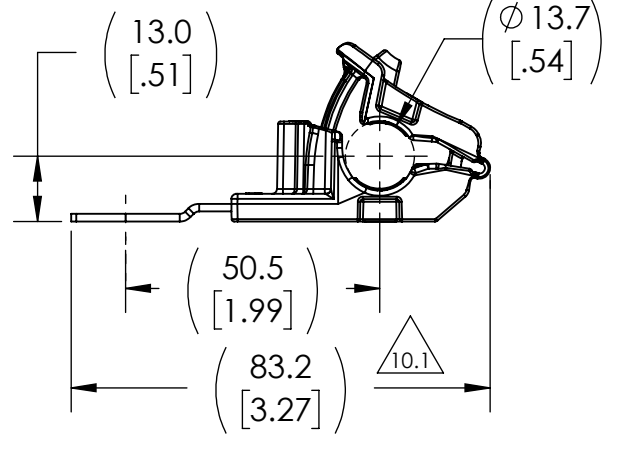
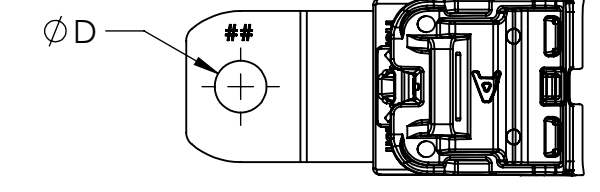
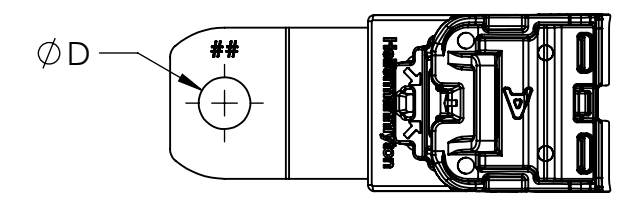
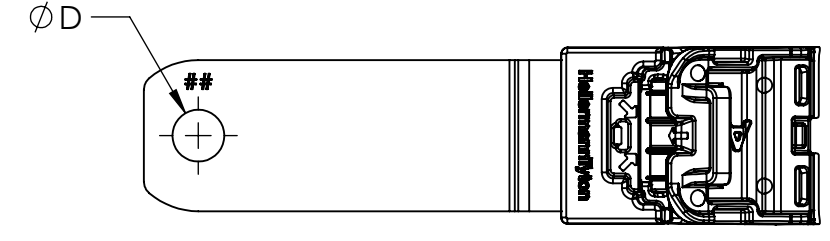
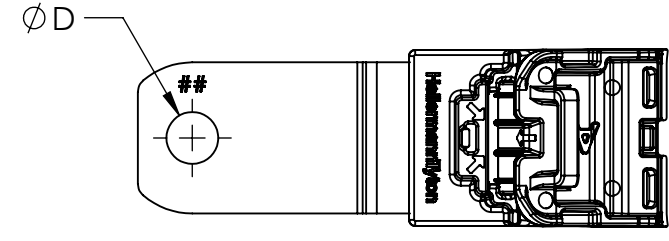
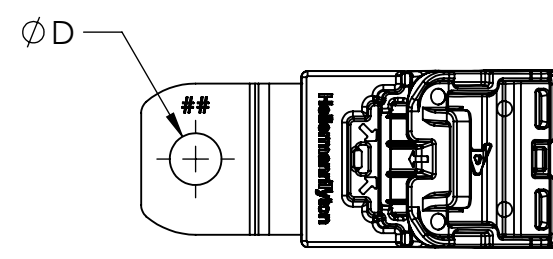

**CONFIGURATION: 1**

**CONFIGURATION: 2**

**CONFIGURATION: 3**

**CONFIGURATION: 4**

**CONFIGURATION: 5**

**ALL VIEWS IN MAXIMUM BUNDLE DIAMETER  
PRODUCT SHIPPED IN CLAMP OPEN POSITION**

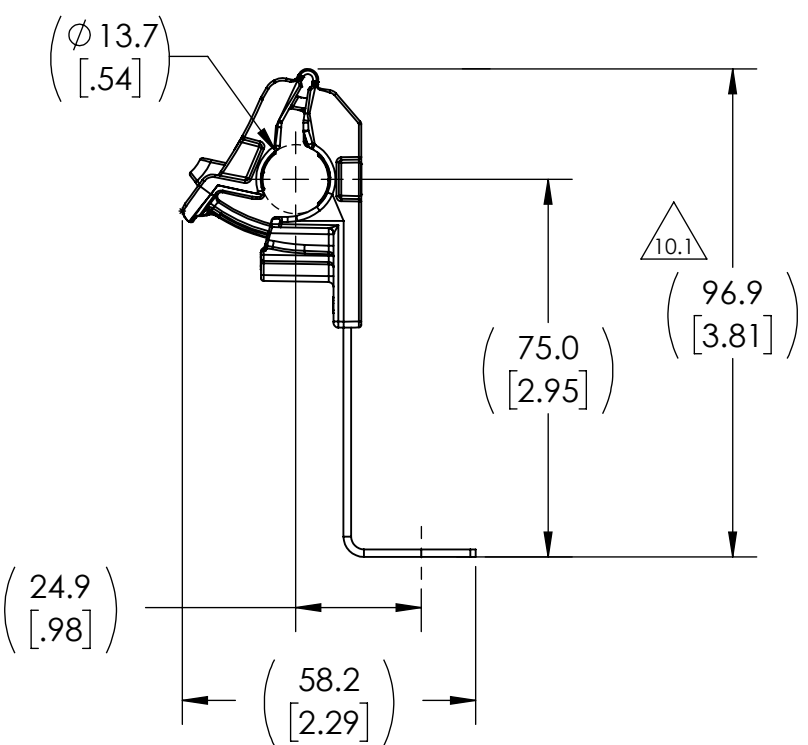
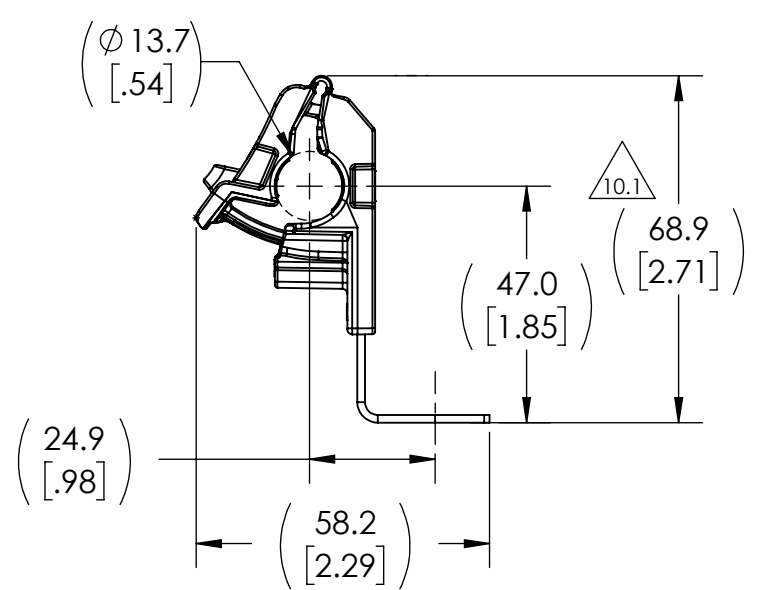
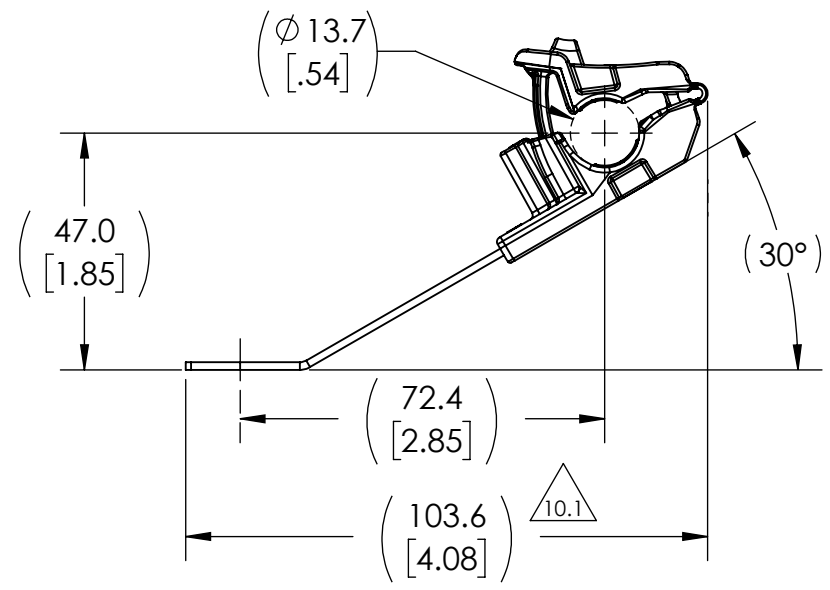
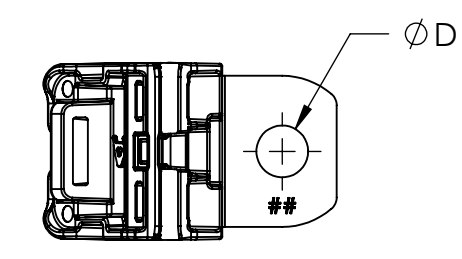
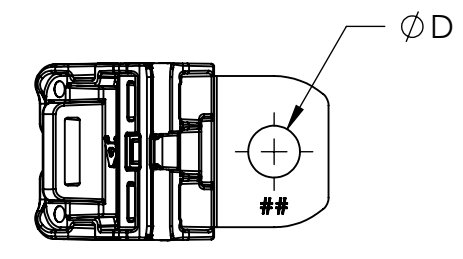
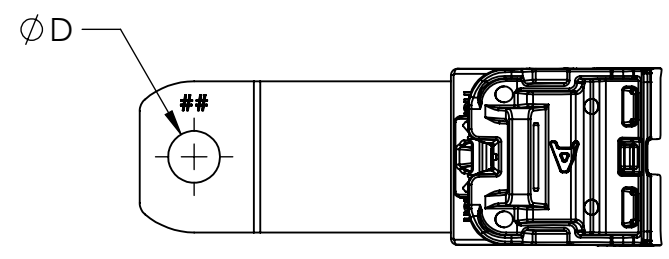

**CONFIGURATION: 6**

**CONFIGURATION: 7**

**CONFIGURATION: 8**

CONFIGURATION	DESCRIPTION	D ±0.13	TYPE	## ENGRAVING	C - OVERALL OPEN LENGTH REFERENCE (SEE SHEET 1)
1	180° SHORT	6.50 [.256]	RCA180SM6	6	116.2 [4.58]
		8.31 [.327]	RCA180SM8	8	
		10.29 [.405]	RCA180SM10	10	
		12.95 [.510]	RCA180SM12	12	
2	180° MEDIUM	6.50 [.256]	RCA180MM6	6	138.2 [5.44]
		8.31 [.327]	RCA180MM8	8	
		10.29 [.405]	RCA180MM10	10	
3	180° LONG	6.50 [.256]	RCA180LM6	6	167.2 [6.58]
		8.31 [.327]	RCA180LM8	8	
		10.29 [.405]	RCA180LM10	10	
4	15° SHORT	6.50 [.256]	RCA15SM6	6	124.1 [4.89]
		8.31 [.327]	RCA15SM8	8	
		10.29 [.405]	RCA15SM10	10	
5	30° SHORT	6.50 [.256]	RCA30SM6	6	122.0 [4.80]
		8.31 [.327]	RCA30SM8	8	
		10.29 [.405]	RCA30SM10	10	
6	30° LONG	6.50 [.256]	RCA30LM6	6	150.5 [5.93]
		8.31 [.327]	RCA30LM8	8	
		10.29 [.405]	RCA30LM10	10	
7	90° SHORT	6.50 [.256]	RCA90SM6	6	101.9 [4.01]
		8.31 [.327]	RCA90SM8	8	
		10.29 [.405]	RCA90SM10	10	
8	90° LONG	6.50 [.256]	RCA90LM6	6	129.9 [5.12]
		8.31 [.327]	RCA90LM8	8	
		10.29 [.405]	RCA90LM10	10	
		12.95 [.510]	RCA90LM12	12	

Notes	Material	Units:	millimeters	Drawn	MHT	05/26/2015	Article/Type-No	SEE CHART SHEET 2	Scale	2:3	
	1. PA66HIRHSUV 2. ZINC PLATED STEEL	Dimension without tolerances details to: .xxx = ±.013 .xx = ±.13 .x = ±.3 None = ±.8 < = ±0.5*	Dimension Formatted mm{in}	Approved	KAC	05/28/2015	Title	RCA RATCHET P CLAMP, SIZE A, CLAMP RANGE 6.0 TO 13.7	Project Number	PRP15-0341	
				The copyright of this drawing is reserved by HellermannTyton. It is issued on condition that it is not reproduced, copied, or disclosed to a third party, either wholly or in part, without the consent of HellermannTyton.			HellermannTyton		Production: Phase	Format	C
				North America Email: corp@htamericas.com Web: www.hellermann-tyton.com			Drawing-No		15-0341-102-CSU	Sheet	2/2

## X-ON Electronics

Largest Supplier of Electrical and Electronic Components

*Click to view similar products for [Cable Mounting & Accessories](#) category:*

*Click to view products by [HellermannTyton](#) manufacturer:*

Other Similar products are found below :

[582603-1](#) [009333-000](#) [727844N003](#) [747](#) [809090N001](#) [843188-000](#) [8666](#) [967279N002](#) [DB-11](#) [1300840039](#) [1300900096](#) [1301800416](#)  
[1302264450](#) [1300830184](#) [1300830729](#) [1300900039](#) [1301580036](#) [1301850553](#) [1301860939](#) [1302000074](#) [1302261315](#) [1302264431](#)  
[1337706-2](#) [APA18-AK](#) [1724](#) [1-787307-1](#) [185491N001](#) [1868](#) [HP-6N](#) [C-202-C](#) [202C221-13-0](#) [CA7308-000](#) [8S23-75FR-CS8184](#) [2684](#) [9648](#)  
[3089](#) [988382-000](#) [A72821-000](#) [AA401](#) [173506-000](#) [1823](#) [202C292-13-0](#) [202C302-13-0](#) [2109](#) [300625](#) [3330](#) [3412](#) [356247-1](#) [M9142](#)  
[M9143](#)