

Revision level			Revision Record	Changed	Date	Approved	Date
Drawing	State	Part					
10.1	Design Release	B	SEE ECN# 015124	CTF	05/07/2019	MHT	05/07/2019

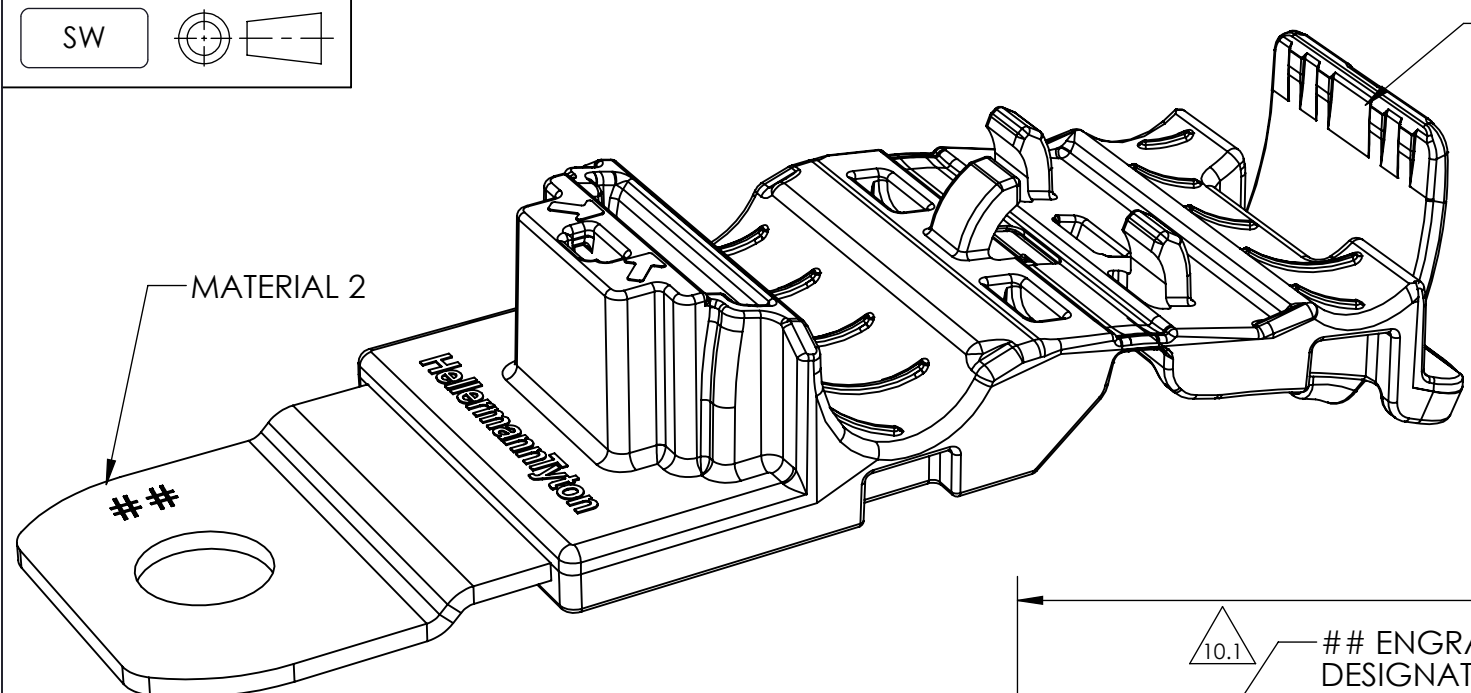

**CONFIGURATION 1 SHOWN
PRODUCT SHIPPED IN CLAMP OPEN POSITION**

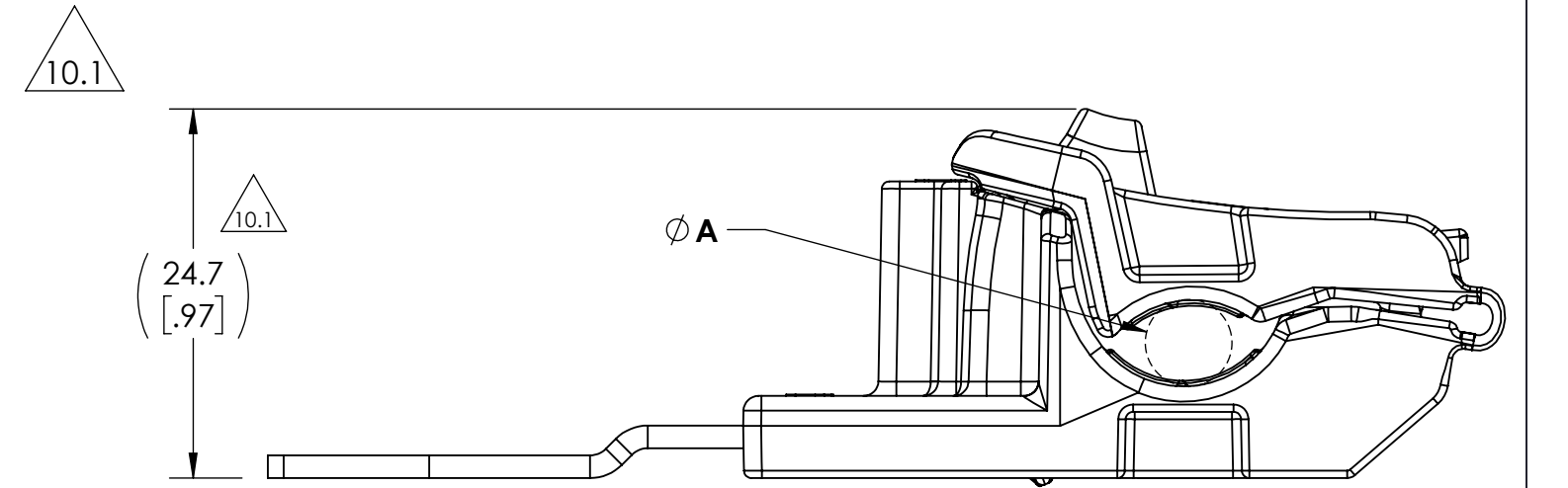
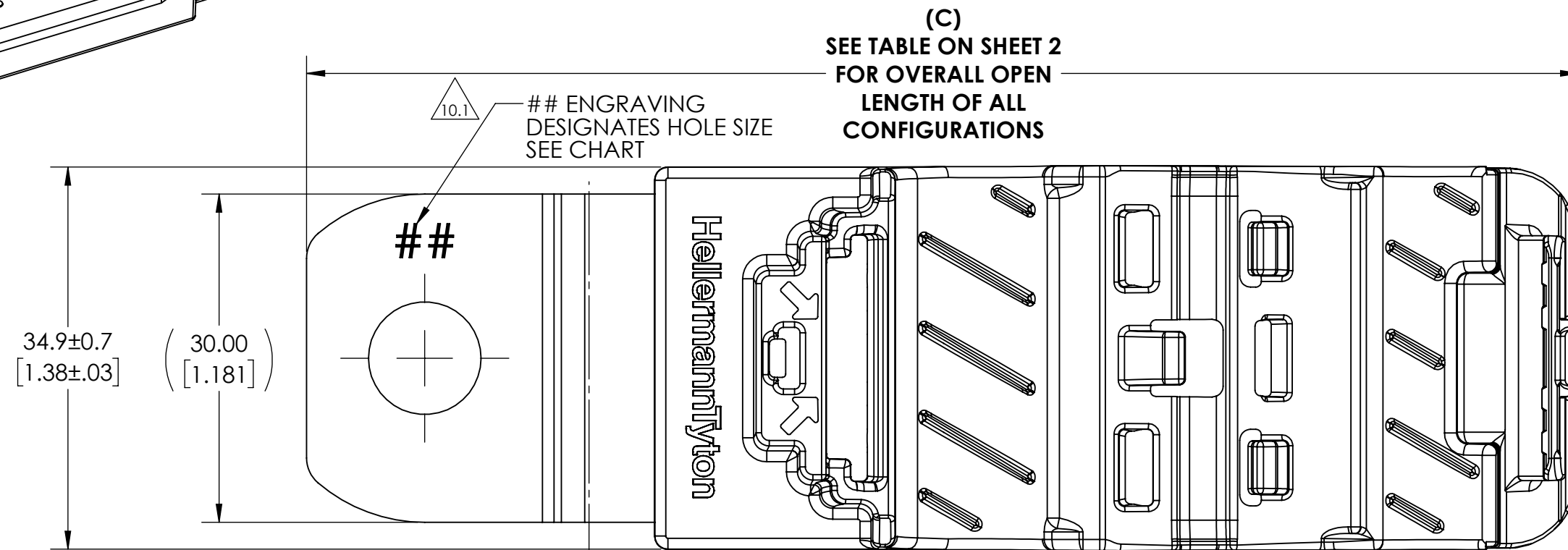

MINIMUM BUNDLE DIAMETER

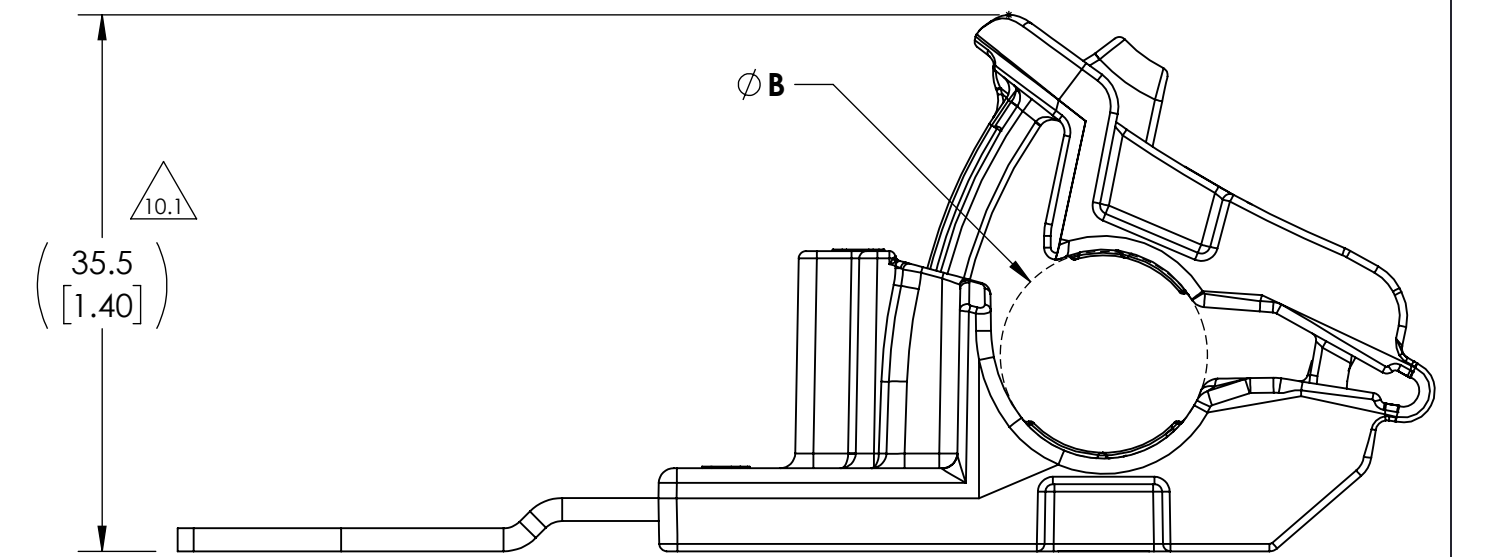

MAXIMUM BUNDLE DIAMETER

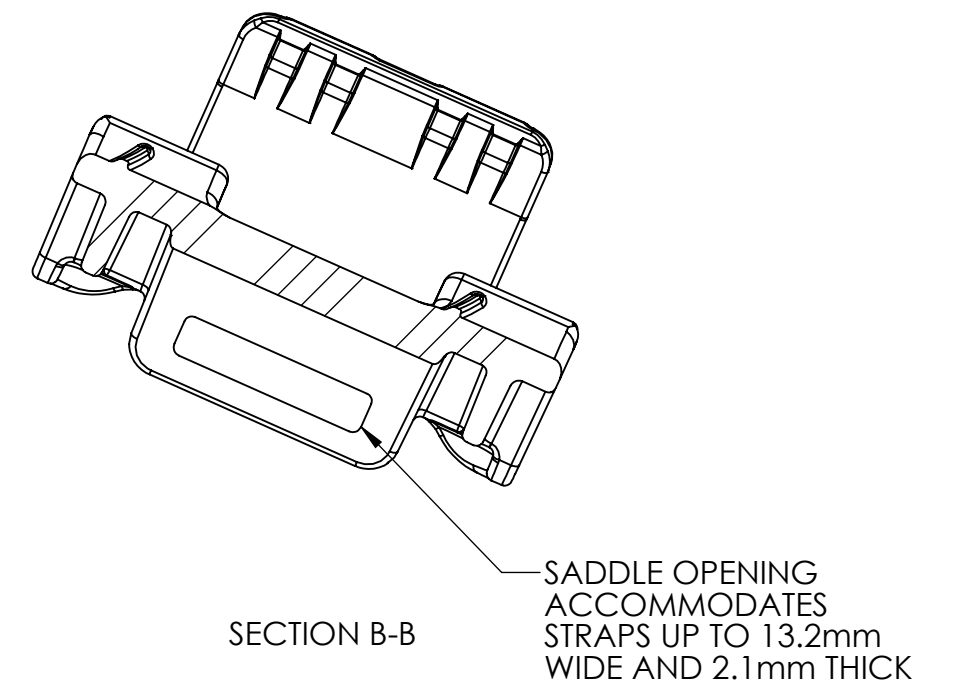
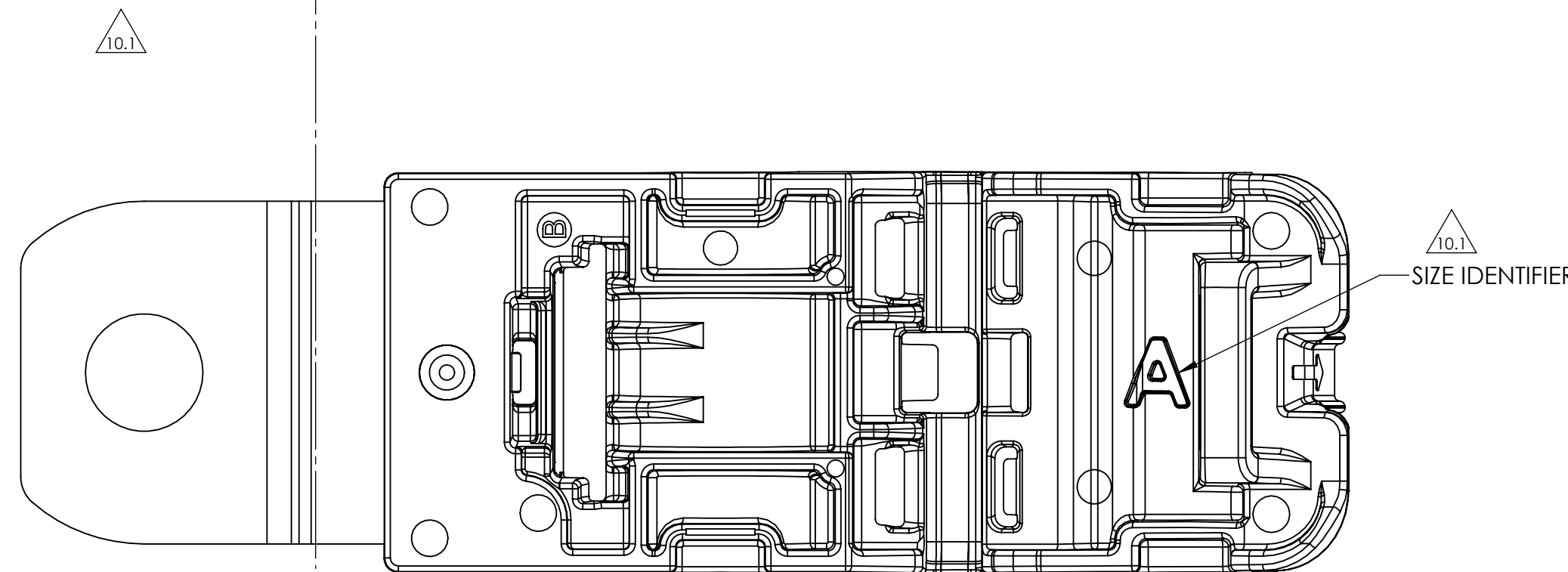
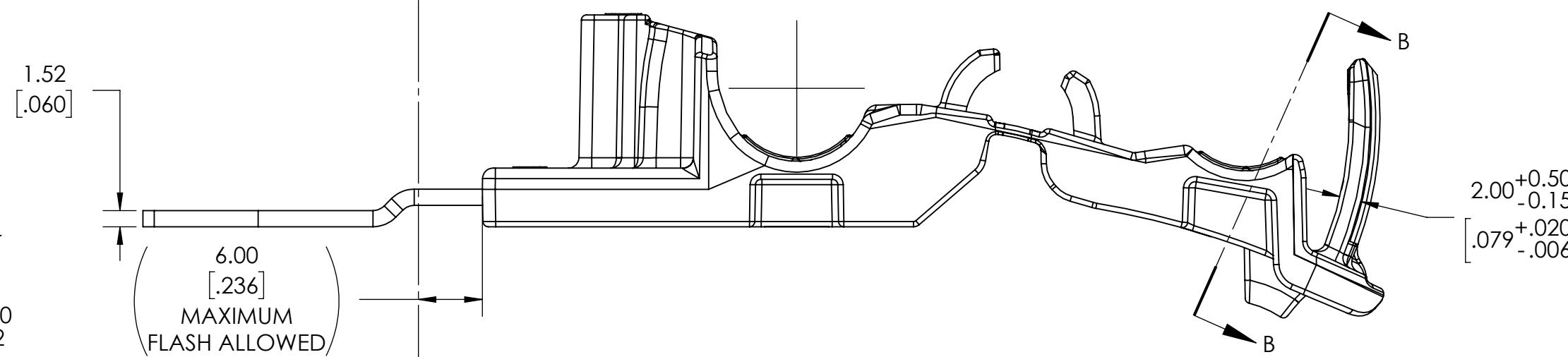

INITIAL MOLD VALIDATION:

DRY AS MOLDED WITH ≤ 0.5% MOISTURE CONTENT:

1. ITS-0003 RATCHET CLAMP SOLID MANDREL TEST:
EXCEEDED 445 NEWTONS (100 LBS) MIN AT A
NOMINAL BUNDLE DIAMETER OF 9.53 [0.375]
TESTING ONLY REQUIRED OF CONFIGURATION
*RCA180SM10, *RCA180LM10, AND *RCA90LM10
*TESTING CAN BE SUBSTITUTED WITH M6, M8, M12
VERSION MOUNTING HOLES
2. ITS-0008 RATCHET CLAMP CLOSE AND RELEASE TEST:
EXCEEDED 445 NEWTONS (100 LBS) MIN AT A
NOMINAL BUNDLE DIAMETER OF 9.53 [0.375] AFTER
CLOSING AND RELEASING 40 TIMES
3. ITS-0014 RATCHET CLAMP LOW TEMPERATURE HINGE
TEST:
NO DAMAGE OCCURED AFTER BENDING LIVING
HINGE 40 TIMES AT -40°C

PERFORMANCE REQUIREMENTS:

DRY AS MOLDED WITH ≤ 0.5% MOISTURE CONTENT:

4. ITS-0001 RATCHET CLAMP SPLIT MANDREL TEST:
445 NEWTONS (100 LBS) MIN AT A NOMINAL BUNDLE
DIAMETER OF 9.53 [0.375]
5. MAXIMUM PERCENT REGRIND PERMISSABLE: 25%
6. MAXIMUM ALLOWABLE FLASH OR MISMATCH TO BE:
0.25mm

NOTE: TESTING #2, #3 AND #4 CAN BE DONE ON ANY TYPE
NUMBER AND WILL APPLY TO ALL OTHER TYPE NUMBERS IN
THE TABLE ON SHEET 2

BUNDLE TYPES	A MINIMUM DIAMETER	B MAXIMUM DIAMETER
SOFT	6.2 [.24]	13.7 [.54]
HARD	5.4 [.21]	12.9 [.51]

Notes	Material	Units: millimeters	Drawn	MHT	05/26/2015	Article/Type-No	SEE CHART SHEET 2	Scale	2:1
	1. PA66HIRHSUV 2. ZINC PLATED STEEL	Dimension without tolerances details to: .xxx = ±.013 .xx = ±.13 .x = ±.3 None = ±.8 < = ±0.5*	Approved	KAC	05/28/2015	Title	RCA RATCHET P CLAMP, SIZE A, CLAMP RANGE 6.0 TO 13.7	Project Number	PRP15-0341
			The copyright of this drawing is reserved by HellermannTyton. It is issued on condition that it is not reproduced, copied, or disclosed to a third party, either wholly or in part, without the consent of HellermannTyton.		HellermannTyton North America Email: corp@htamericas.com Web: www.hellermann.tyton.com		Production: Phase	Format	C
	Dimension Formatted mm{in}		Drawing-No		15-0341-102-CSU		Sheet	1/2	

Revision level			Revision Record	Changed	Date	Approved	Date
Drawing	State	Part					
10.1	Design Release	B	SEE ECN# 015124	CTF	05/07/2019	MHT	05/07/2019

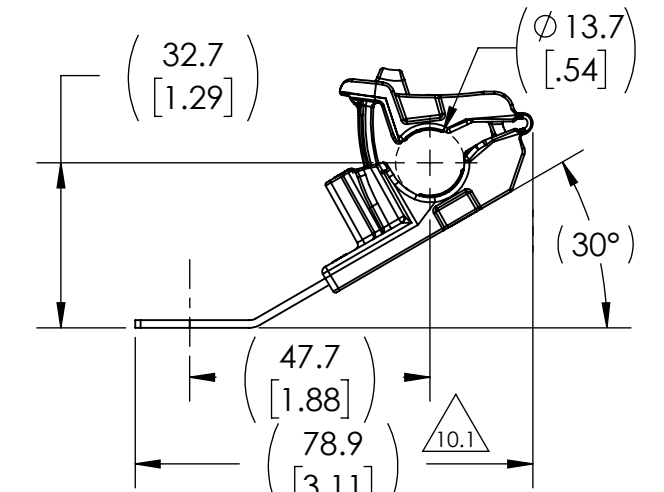
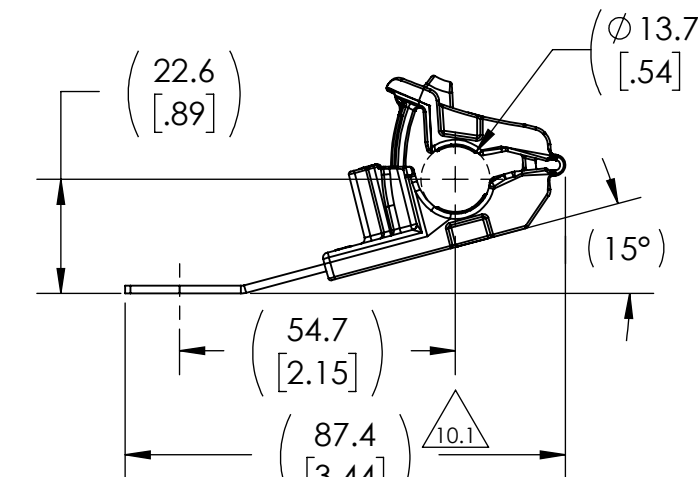
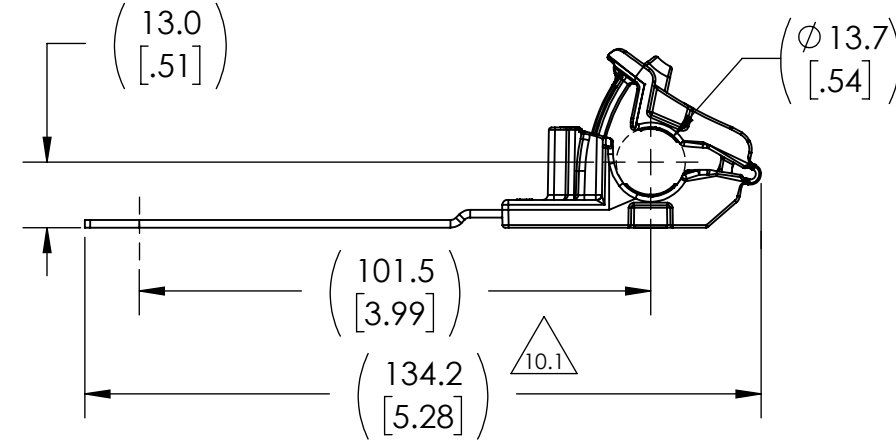
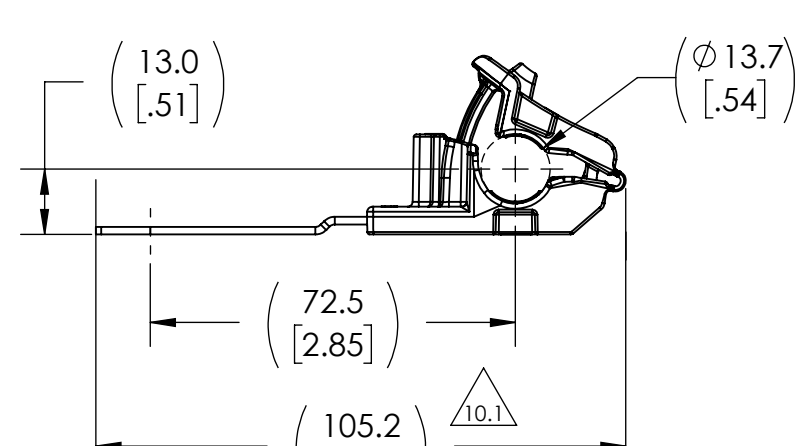
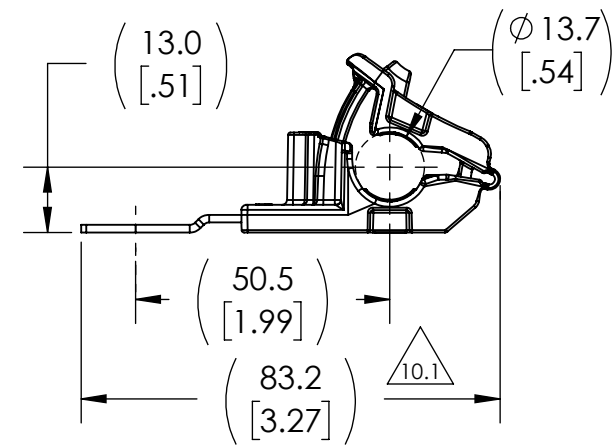
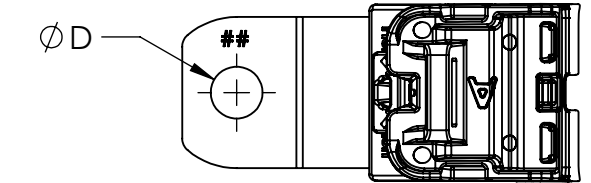
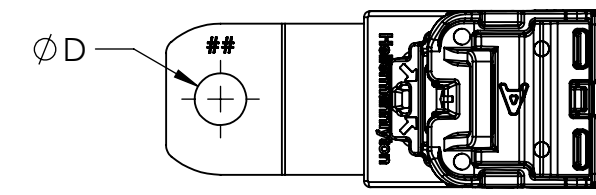
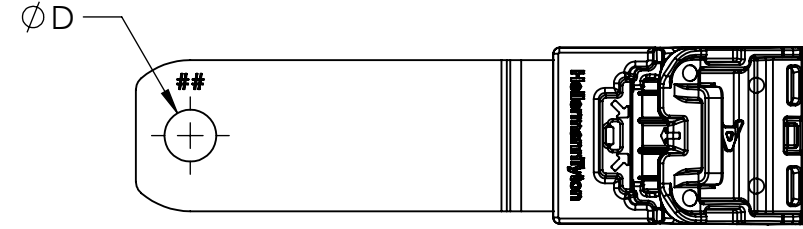
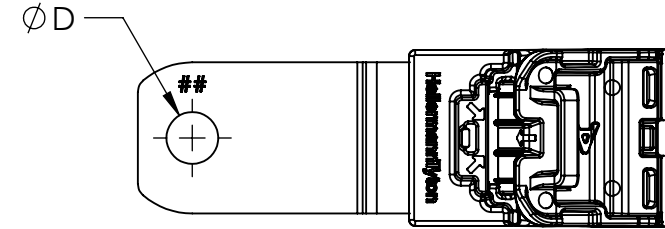
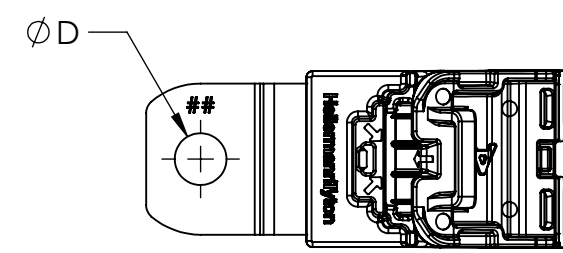

CONFIGURATION: 1

CONFIGURATION: 2

CONFIGURATION: 3

CONFIGURATION: 4

CONFIGURATION: 5

ALL VIEWS IN MAXIMUM BUNDLE DIAMETER
PRODUCT SHIPPED IN CLAMP OPEN POSITION

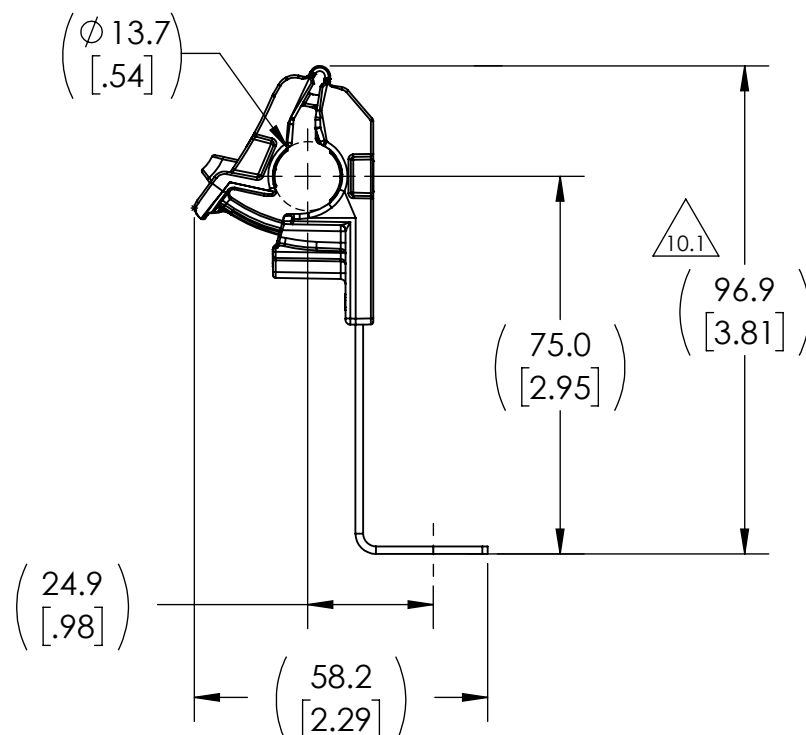
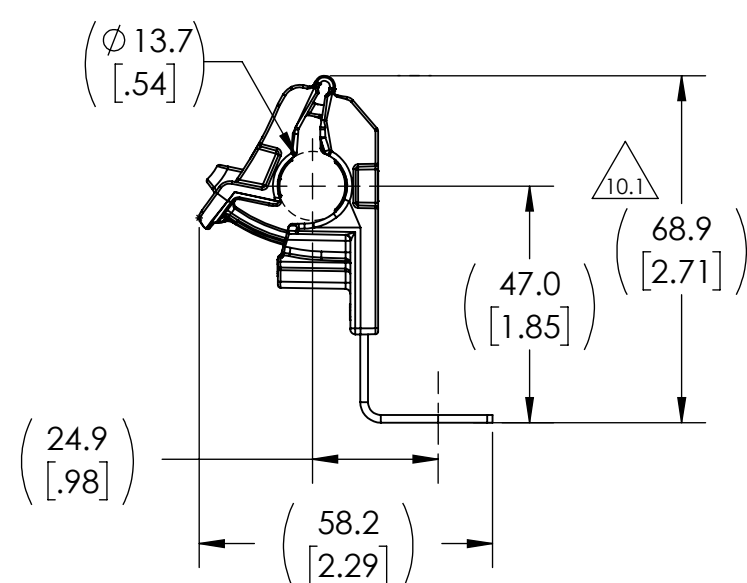
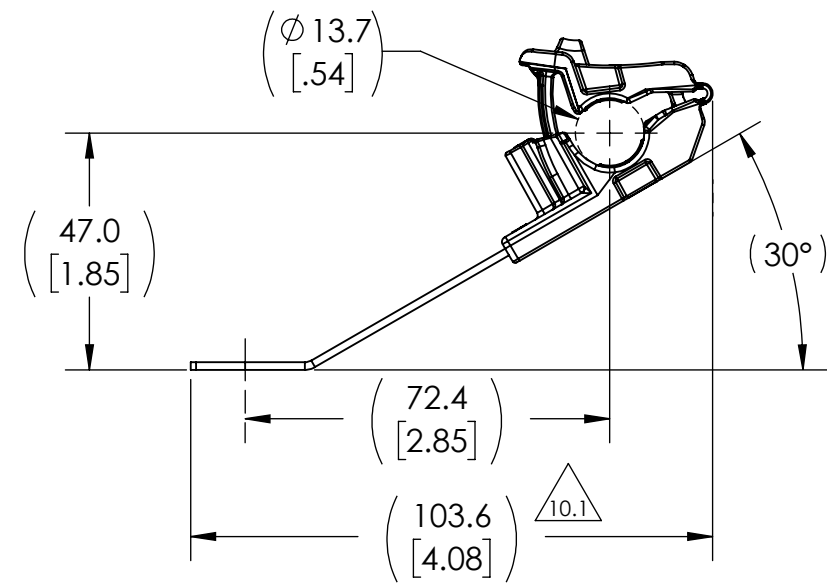
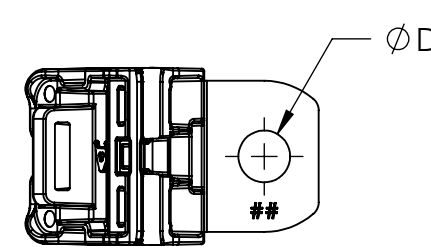
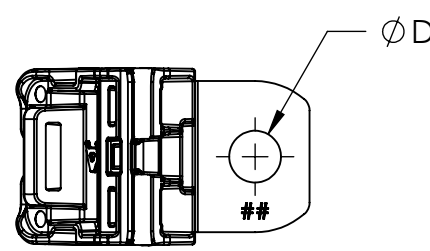
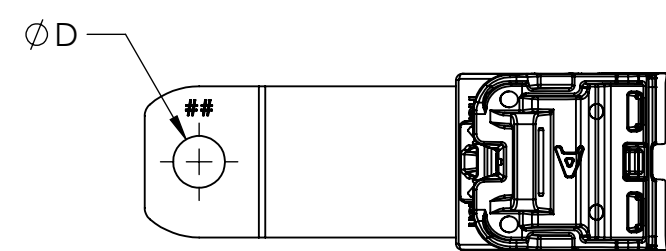

CONFIGURATION: 6

CONFIGURATION: 7

CONFIGURATION: 8

CONFIGURATION	DESCRIPTION	D ±0.13	TYPE	## ENGRAVING	C - OVERALL OPEN LENGTH REFERENCE (SEE SHEET 1)
1	180° SHORT	6.50 [.256]	RCA180SM6	6	116.2 [4.58]
		8.31 [.327]	RCA180SM8	8	
		10.29 [.405]	RCA180SM10	10	
		12.95 [.510]	RCA180SM12	12	
2	180° MEDIUM	6.50 [.256]	RCA180MM6	6	138.2 [5.44]
		8.31 [.327]	RCA180MM8	8	
		10.29 [.405]	RCA180MM10	10	
3	180° LONG	6.50 [.256]	RCA180LM6	6	167.2 [6.58]
		8.31 [.327]	RCA180LM8	8	
		10.29 [.405]	RCA180LM10	10	
4	15° SHORT	6.50 [.256]	RCA15SM6	6	124.1 [4.89]
		8.31 [.327]	RCA15SM8	8	
		10.29 [.405]	RCA15SM10	10	
5	30° SHORT	6.50 [.256]	RCA30SM6	6	122.0 [4.80]
		8.31 [.327]	RCA30SM8	8	
		10.29 [.405]	RCA30SM10	10	
6	30° LONG	6.50 [.256]	RCA30LM6	6	150.5 [5.93]
		8.31 [.327]	RCA30LM8	8	
		10.29 [.405]	RCA30LM10	10	
7	90° SHORT	6.50 [.256]	RCA90SM6	6	101.9 [4.01]
		8.31 [.327]	RCA90SM8	8	
		10.29 [.405]	RCA90SM10	10	
8	90° LONG	6.50 [.256]	RCA90LM6	6	129.9 [5.12]
		8.31 [.327]	RCA90LM8	8	
		10.29 [.405]	RCA90LM10	10	
		12.95 [.510]	RCA90LM12	12	

Notes	Material 1. PA66HIRHSUV 2. ZINC PLATED STEEL	Units: millimeters Dimension without tolerances details to: .xxx = ±.013 .xx = ±.13 .x = ±.3 None = ±.8 < = ±0.5*	The copyright of this drawing is reserved by HellermannTyton. It is issued on condition that it is not reproduced, copied, or disclosed to a third party, either wholly or in part, without the consent of HellermannTyton.	Drawn	MHT	05/26/2015	Article/Type-No SEE CHART SHEET 2	Scale 2:3		
				Approved	KAC	05/28/2015			Title RCA RATCHET P CLAMP, SIZE A, CLAMP RANGE 6.0 TO 13.7	Project Number PRP15-0341
				HellermannTyton North America Email: corp@htamericas.com Web: www.hellermann-tyton.com		Drawing-No 15-0341-102-CSU			Production: Phase C	Sheet 2/2

X-ON Electronics

Largest Supplier of Electrical and Electronic Components

Click to view similar products for [Cable Mounting & Accessories](#) category:

Click to view products by [HellermannTyton](#) manufacturer:

Other Similar products are found below :

[582603-1](#) [009333-000](#) [727844N003](#) [747](#) [809090N001](#) [843188-000](#) [8666](#) [967279N002](#) [DB-11](#) [1300840039](#) [1300900096](#) [1301800416](#)
[1302264450](#) [1300830184](#) [1300830729](#) [1300900039](#) [1301580036](#) [1301850553](#) [1301860939](#) [1302000074](#) [1302261315](#) [1302264431](#)
[1337706-2](#) [APA18-AK](#) [1724](#) [1-787307-1](#) [185491N001](#) [1868](#) [HP-6N](#) [C-202-C](#) [202C221-13-0](#) [CA7308-000](#) [8S23-75FR-CS8184](#) [2684](#) [9648](#)
[3089](#) [988382-000](#) [A72821-000](#) [AA401](#) [173506-000](#) [1823](#) [202C292-13-0](#) [202C302-13-0](#) [2109](#) [300625](#) [3330](#) [3412](#) [356247-1](#) [M9142](#)
[M9143](#)