

60V N-Channel Enhancement Mode MOSFET

Description

The HX2310 uses advanced trench technology and design to provide excellent $R_{DS(ON)}$ with low gate charge. It can be used in a wide variety of applications.

General Features

- ◆ $V_{DS} = 60V$ $I_D = 3A$
 $R_{DS(ON)} < 90m\Omega$ @ $V_{GS} = 10V$ (Typ: 76m Ω)
 $R_{DS(ON)} < 100m\Omega$ @ $V_{GS} = 4.5V$ (Typ: 88m Ω)
- ◆ High density cell design for ultra low R_{dson} .
- ◆ Fully characterized avalanche voltage and current.
- ◆ Low gate to drain charge to reduce switching losses.

Application

- ◆ Power switching application.
- ◆ Hard switched and high frequency circuits.
- ◆ Uninterruptible power supply.

Package

- ◆ SOT-23



Schematic diagram

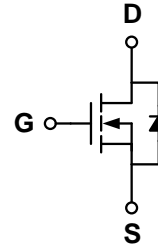

Marking and pin assignment

SOT-23
(TOP VIEW)

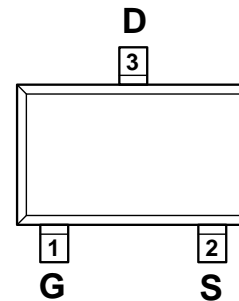

Ordering Information

Part Number	Storage Temperature	Package	Devices Per Reel
HX2310	-55°C to +150°C	SOT-23	3000

Absolute Maximum Ratings (TA=25°C unless otherwise noted)

parameter	symbol	limit	unit
Drain-source voltage	V_{DS}	60	V
Gate-source voltage	V_{GS}	± 20	V
Continuous Drain Current (T _J = 150 °C)	I_D	T _C =25°C	3
		T _C =70°C	2
		T _A =25°C	1.6 ^{b,c}
		T _A =70°C	1.3 ^{b,c}
Continuous Source-Drain Diode Current	I_S	T _C =25°C	2.1
		T _A =25°C	1 ^{b,c}
Pulsed Drain Current (t = 300 μ s)	I_{DM}	12	
Maximum power dissipation	P_D	2.5	W

	$T_C=70^{\circ}\text{C}$		1.6	
	$T_A=25^{\circ}\text{C}$		1.25 ^{b,c}	
	$T_A=70^{\circ}\text{C}$		0.8 ^{b,c}	
Operating Junction and Storage Temperature Range		T_J, T_{STG}	-55—150	$^{\circ}\text{C}$

Thermal Characteristics

Parameter		Symbol	Typical	Maximum	Unit
Maximum Junction-to-Ambient ^{b, d}	$t \leq 5 \text{ s}$	$R_{\theta JA}$	100	130	$^{\circ}\text{C/W}$
Maximum Junction-to-Foot (Drain)	Steady State	$R_{\theta JF}$	60	75	

Notes:

- a: $T_C = 25^{\circ}\text{C}$. b: Surface mounted on 1" x 1" FR4 board.
 c: $t = 5 \text{ s}$. d: Maximum under steady state conditions is 175°C/W .

Electrical Characteristics ($T_A=25^{\circ}\text{C}$ unless otherwise noted)

Parameter	Symbol	Condition	Min	Typ	Max	Unit
Static Characteristics						
Drain-source breakdown voltage	BV_{DSS}	$V_{GS}=0\text{V}, I_D=250\mu\text{A}$	60	-	-	V
BVDSS Temperature Coefficient	$\Delta BV_{DSS}/\Delta T_J$	Reference to $25^{\circ}\text{C}, I_D=1\text{mA}$		33		$\text{mV}/^{\circ}\text{C}$
Zero gate voltage drain current	I_{DSS}	$V_{DS}=60\text{V}, V_{GS}=0\text{V}$	-	-	1	μA
		$T_J=85^{\circ}\text{C}$	-	-	30	
Gate Leakage Current	I_{GSS}	$V_{DS}=0\text{V}, V_{GS}=\pm 20\text{V}$	-	-	± 100	nA
Gate threshold voltage	$V_{GS(th)}$	$V_{DS}=V_{GS}, I_D=250\mu\text{A}$	1.2	1.9	2.5	V
Drain-source on-state resistance ¹	$R_{DS(ON)}$	$V_{GS}=10\text{V}, I_D=3\text{A}$	-	78	90	m Ω
		$V_{GS}=4.5\text{V}, I_D=2\text{A}$		88	100	
On Status Drain Current	$I_{D(ON)}$	$V_{DS}=10\text{V}, V_{GS}=10\text{V}$	3	-	-	A
Diode Characteristics						
Diode Forward Voltage	V_{SD}	$I_{SD}=1\text{A}, V_{GS}=0\text{V}$	-	0.75	1.1	V
Diode Continuous Forward Current	I_S		-	-	3	A
Reverse Recovery Time	t_{rr}	$I_F=1.5\text{A},$ $dI/dt=100\text{A}/\mu\text{s}$	-	15	-	ns
Reverse Recovery Charge	Q_{rr}		-	12	-	nC
Dynamic Characteristics²						
Gate Resistance	R_G	$V_{GS}=0\text{V}, V_{DS}=0\text{V}, f=1\text{MHz}$	-	2.0	-	Ω
Input capacitance	C_{ISS}	$V_{GS}=0\text{V}, V_{DS}=25\text{V}$ $f=1.0\text{MHz}$	-	175	-	pF
Output capacitance	C_{OSS}		-	21	-	
Reverse transfer capacitance	C_{RSS}		-	13	-	
Turn-on delay time	$t_{D(ON)}$	$V_{GS}=10\text{V}, V_{DD}=30\text{V},$ $R_L=4.7\Omega, I_D=1.5\text{A},$ $R_G=3.3\Omega$	-	15	-	ns
Turn-on Rise time	t_r		-	16	-	
Turn-off delay time	$t_{D(OFF)}$		-	10	-	
Turn-off Fall time	t_f		-	10	-	

Total gate charge	Q_g	$V_{GS}=10V, I_D=2A$ $V_{DS}=30V$	-	4.1	nC
Gate-source charge	Q_{gs}			0.8	
Gate-drain charge	Q_{gd}		-	1	

Package Information

- SOT-23

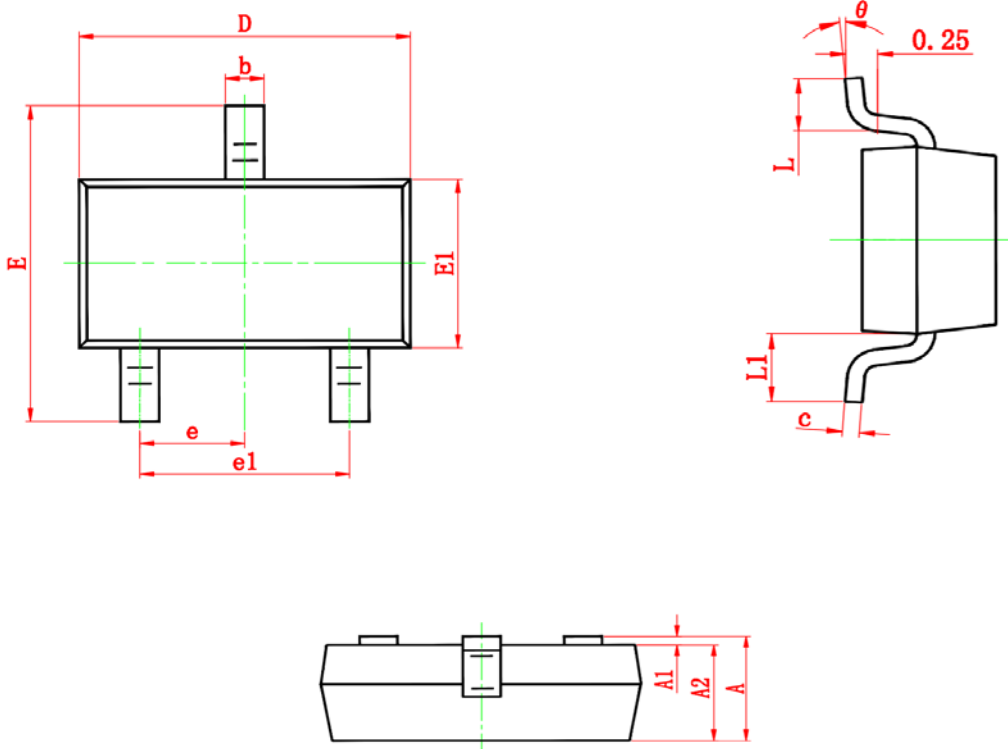

Symbol	Dimensions In Millimeters		Dimensions In Inches	
	Min.	Max.	Min.	Max.
A	0.900	1.150	0.035	0.045
A1	0.000	0.100	0.000	0.004
A2	0.900	1.050	0.035	0.041
b	0.300	0.500	0.012	0.020
c	0.080	0.150	0.003	0.006
D	2.800	3.000	0.110	0.118
E	2.250	2.550	0.089	0.100
E1	1.200	1.400	0.047	0.055
e	0.950 TYP.		0.037 TYP.	
e1	1.800	2.000	0.071	0.079
L	0.300	0.500	0.012	0.020
L1	0.550 REF.		0.022 REF.	
θ	0°	8°	0°	8°

X-ON Electronics

Largest Supplier of Electrical and Electronic Components

Click to view similar products for [MOSFET](#) category:

Click to view products by [hengjiaxing](#) manufacturer:

Other Similar products are found below :

[IRFD120](#) [IRFY240C](#) [JANTX2N5237](#) [BUK455-60A/B](#) [MIC4420CM-TR](#) [VN1206L](#) [NDP4060](#) [SI4482DY](#) [IPS70R2K0CEAKMA1](#)
[SQD23N06-31L-GE3](#) [TK16J60W,S1VQ\(O](#) [2SK2614\(TE16L1,Q\)](#) [DMN1017UCP3-7](#) [EFC2J004NUZTDG](#) [DMN1053UCP4-7](#) [SQJ469EP-](#)
[T1-GE3](#) [NTE2384](#) [DMC2700UDMQ-7](#) [DMN2080UCB4-7](#) [DMN61D9UWQ-13](#) [US6M2GTR](#) [DMN31D5UDJ-7](#) [DMP22D4UFO-7B](#)
[DMN1006UCA6-7](#) [DMN16M9UCA6-7](#) [STF5N65M6](#) [IRF40H233XTMA1](#) [STU5N65M6](#) [DMN6022SSD-13](#) [DMN13M9UCA6-7](#)
[DMTH10H4M6SPS-13](#) [DMN2990UFB-7B](#) [IPB80P04P405ATMA2](#) [2N7002W-G](#) [MCAC30N06Y-TP](#) [MCQ7328-TP](#) [NTMC083NP10M5L](#)
[NVMFS2D3P04M8LT1G](#) [BXP7N65D](#) [BXP4N65F](#) [AOL1454G](#) [WMJ80N60C4](#) [BXP2N20L](#) [BXP2N65D](#) [BXT1150N10J](#) [BXT1700P06M](#)
[TSM60NB380CP](#) [ROG](#) [RQ7L055BGTCR](#) [DMNH15H110SK3-13](#) [SLF10N65ABV2](#)