

ULN2003 series High-voltage High-current Darlington Transistor Arrays

Features

- 500-mA-Rated Collector Current(single output)
- High-Voltage Outputs:50V
- Output Clamp Diodes
- Inputs Compatible With Various Types of Logic
- Relay-Driver Applications

General Description

The ULN2003 is high-voltage high-current Darlington transistor arrays each containing seven open collector common emitter pairs. Each pair is rated at 500mA. Suppression diodes are included for inductive load driving, the inputs and outputs are pinned in opposition to simplify board layout.

These devices are capable of driving a wide range of loads including solenoids, relays, DC motors, LED displays, filament lamps, thermal print-heads and high-power buffers.

The ULN2003 is available in both a small outline 16-pin package (DIP16, SOP16, SSOP16 and TSSOP16).

Pin Assignments

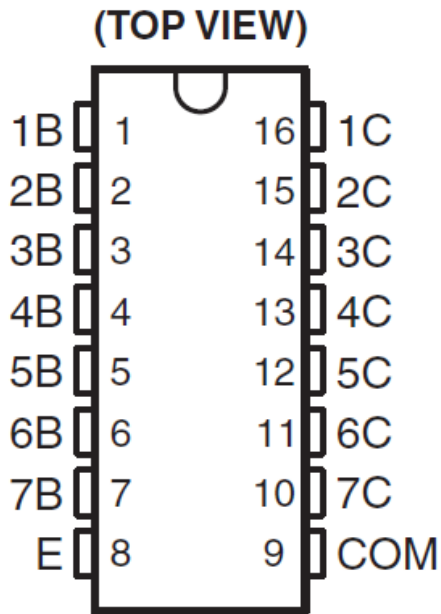

Connection Diagram

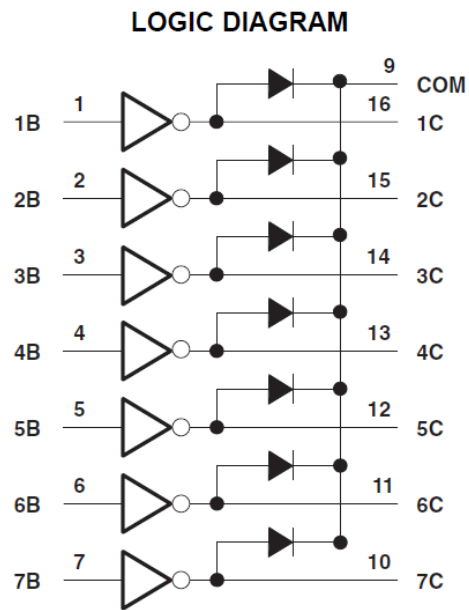

ULN2003 series High -voltage High-current Darlington Transistor Arrays

Pin Descriptions

Pin Number	Pin Name	Function
1	1B	Input pair1
2	2B	Input pair1
3	3B	Input pair1
4	4B	Input pair1
5	5B	Input pair1
6	6B	Input pair1
7	7B	Input pair1
8	E	Common Emitter (ground)
9	COM	Common Clamp Diodes
10	7C	Output pair7
11	6C	Output pair6
12	5C	Output pair5
13	4C	Output pair4
14	3C	Output pair3
15	2C	Output pair2
16	1C	Output pair1

Functional Block Diagram

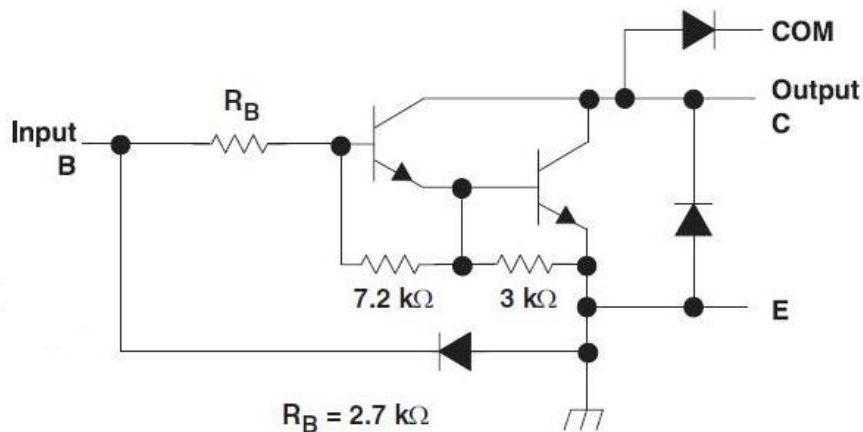

Note: All resistor values shown are nominal.

The collector-emitter diode is a parasitic structure and should not be used to conduct current. If the collector(s) go below ground an external Schottky diode should be added to clamp negative undershoots.

ULN2003 series High-voltage High-current Darlington Transistor Arrays

Absolute Maximum Ratings ⁽¹⁾

At 25°C free-air temperature (unless otherwise noted)

Symbol	Parameter		Min	Max	Unit
V _{CC}	Collector to emitter voltage			50	V
V _R	Clamp diode reverse voltage(2)			50	V
V _I	Input voltage(2)			30	V
I _{CP}	Peak collector current	See typical characteristics		500	mA
I _{OK}	Output clamp current			500	mA
I _{TE}	Total emitter-terminal current			-2.5	A
T _A	Operating free-air temperature range	TX2003	-40	+105	°C
θ _{JA}	Thermal Resistance Junction-to-Ambient(3)			63	°C/W
θ _{JC}	Thermal Resistance Junction-to-Case(4)			12	
T _J	Operating virtual junction temperature			+150	°C
T _{STG}	Storage temperature range		-65	+150	°C
ESD	Human Body Mode		--	3000	V

- (1) Stresses beyond those listed under "absolute maximum ratings" may cause permanent damage to the device. These are stress ratings only, and functional operation of the device at these or any other conditions beyond those indicated under "recommended operating conditions" is not implied. Exposure to absolute-maximum-rated conditions for extended periods may affect device reliability.
- (2) All voltage values are with respect to the emitter/substrate terminal E, unless otherwise noted.
- (3) Maximum power dissipation is a function of T_{J(max)}, θ_{JA}, and T_A. The maximum allowable power dissipation at any allowable ambient temperature is $PD = (T_J(max) - T_A)/\theta_{JA}$. Operating at the absolute maximum T_J of 150°C can affect reliability.
- (4) Maximum power dissipation is a function of T_{J(max)}, θ_{JC}, and T_A. The maximum allowable power dissipation at any allowable ambient temperature is $PD = (T_J(max) - T_A)/\theta_{JC}$. Operating at the absolute maximum T_J of 150°C can affect reliability.

Recommended Operating Conditions

Symbol	Parameter	Min	Max	Unit
V _{CC}	Collector to Emitter voltage	-	50	V
T _A	Operating Ambient Temperature	-40	+105	°C

ULN2003 series High-voltage High-current Darlington Transistor Arrays

Electrical Characteristics (TA = +25°C, unless otherwise specified)

Parameter		Test Figure	Test Conditions		TX2003A			Unit
					MIN	TYP	MAX	
$V_{I(on)}$	On-state input voltage	Figure 6	VCE = 2 V	IC = 200 mA	--	--	2.4	V
				IC = 250 mA	--	--	2.7	
				IC = 300 mA	--	--	3	
$V_{CE(sat)}$	Collector-emitter saturation voltage	Figure 5	II = 250 μ A, IC = 100 mA	--	0.9	1.1	V	
			II = 350 μ A, IC = 200 mA	--	1	1.3		
			II = 500 μ A, IC = 350 mA	--	1.2	1.6		
I_{CEX}	Collector cutoff current	Figure 1	VCE = 50 V, II = 0	--	--	50	μ A	
		Figure 2	VCE = 50 V, TA = +105°C, II = 0	--	--	100		
V_F	Clamp forward voltage	Figure 8	IF = 350 mA	--	1.7	2	V	
$I_{I(off)}$	Off-state input current	Figure 3	VCE = 50 V, IC = 500 μ A	50	65	--	μ A	
II	Input current	Figure 4	VI = 3.85 V	--	0.93	1.35	mA	
			VI = 5 V	--	--	--		
			VI = 12 V	--	--	--		
IR	Clamp reverse current	Figure 7	VR = 50 V		--	--	50	μ A
				TA = 70°C	--	--	100	
Ci	Input capacitance		VI = 0, f = 1 MHz	--	15	25	pF	

Switching Characteristics (TA = +25°C, unless otherwise specified)

Parameter		Test Conditions	TX2003			UNIT
			MIN	TYP	MAX	
t_{PLH}	Propagation delay time, low- to high-level output	See Figure 9		0.25	1	μ s
t_{PHL}	Propagation delay time, high- to low-level output	See Figure 9		0.25	1	μ s
V_{OH}	High-level output voltage after switching	VS = 50 V, IO = 300 mA, See Figure 9	VS-20			mV

ULN2003 series High-voltage High-current Darlington Transistor Arrays

Parameter Measurement Information

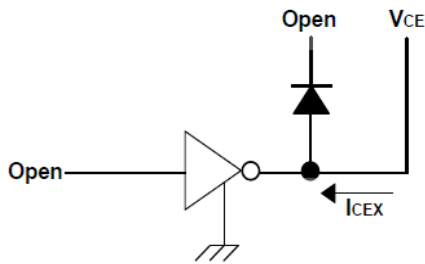

Fig.1 ICEX Test Circuit

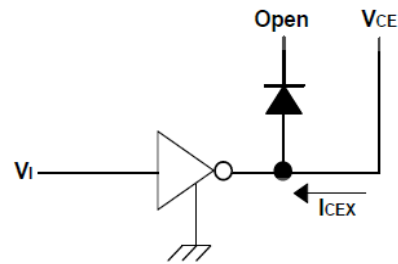

Fig.2 ICEX Test Circuit

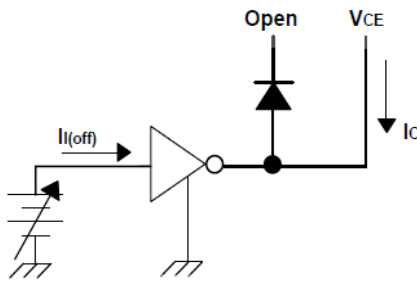

Fig.3 I(off) Test Circuit

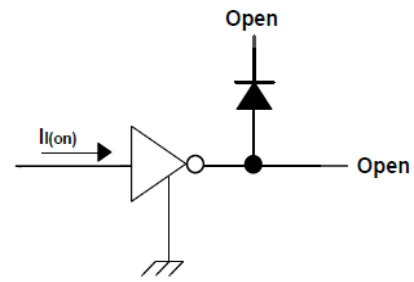

Fig.4 I(on) Test Circuit

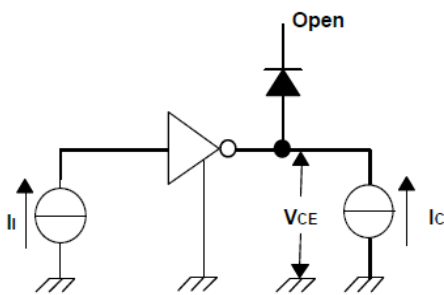

Fig. 5 h_{FE} , $V_{CE(sat)}$ Test Circuit

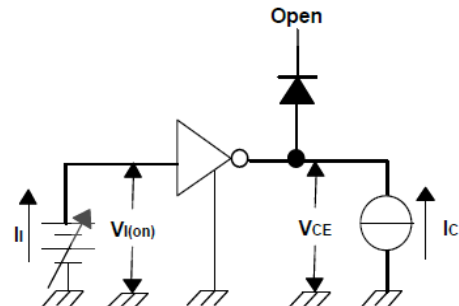

Fig. 6 $V_{(on)}$ Test Circuit

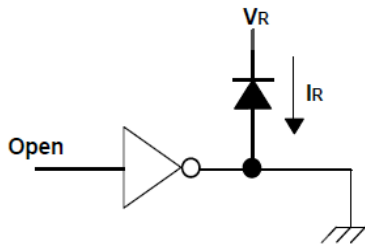

Fig. 7 I_R Test Circuit

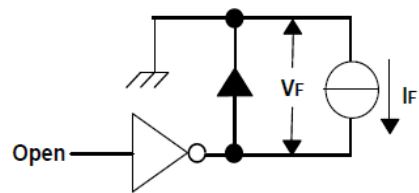

Fig. 8 V_F Test Circuit

ULN2003 series High-voltage High-current Darlington Transistor Arrays

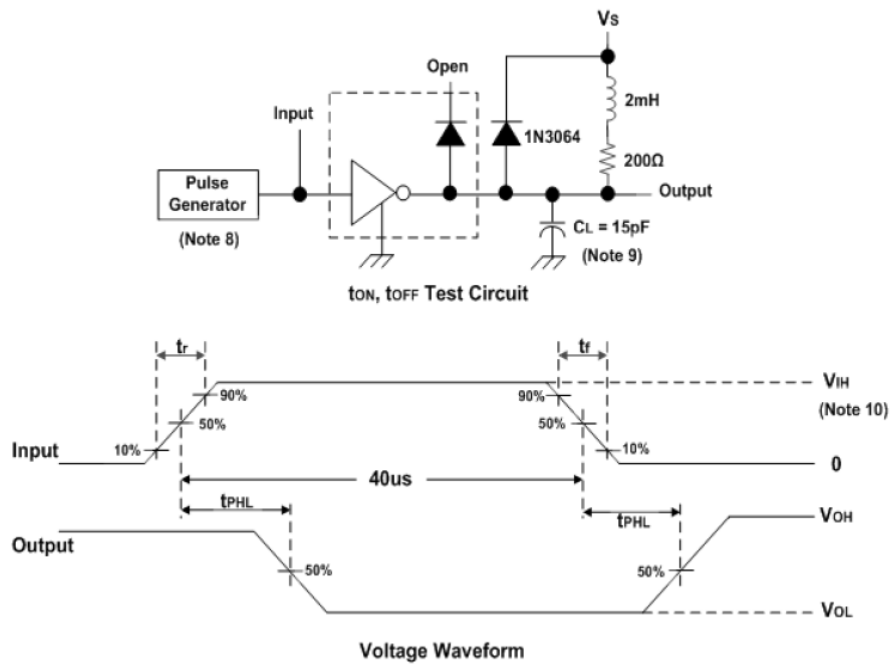

Fig. 9 Latch-Up Test Circuit and Voltage Waveform

Notes: 8. The pulse generator has the following characteristics:

Pulse Width=12.5Hz, output impedance 50Ω, $t_r \leq 5\text{ns}$, $t_f \leq 10\text{ns}$.

9. C_L includes probe and jig capacitance.

10. $V_{IH} = 3\text{V}$

ULN2003 series High-voltage High-current Darlington Transistor Arrays

DIP16 Outline Dimensions

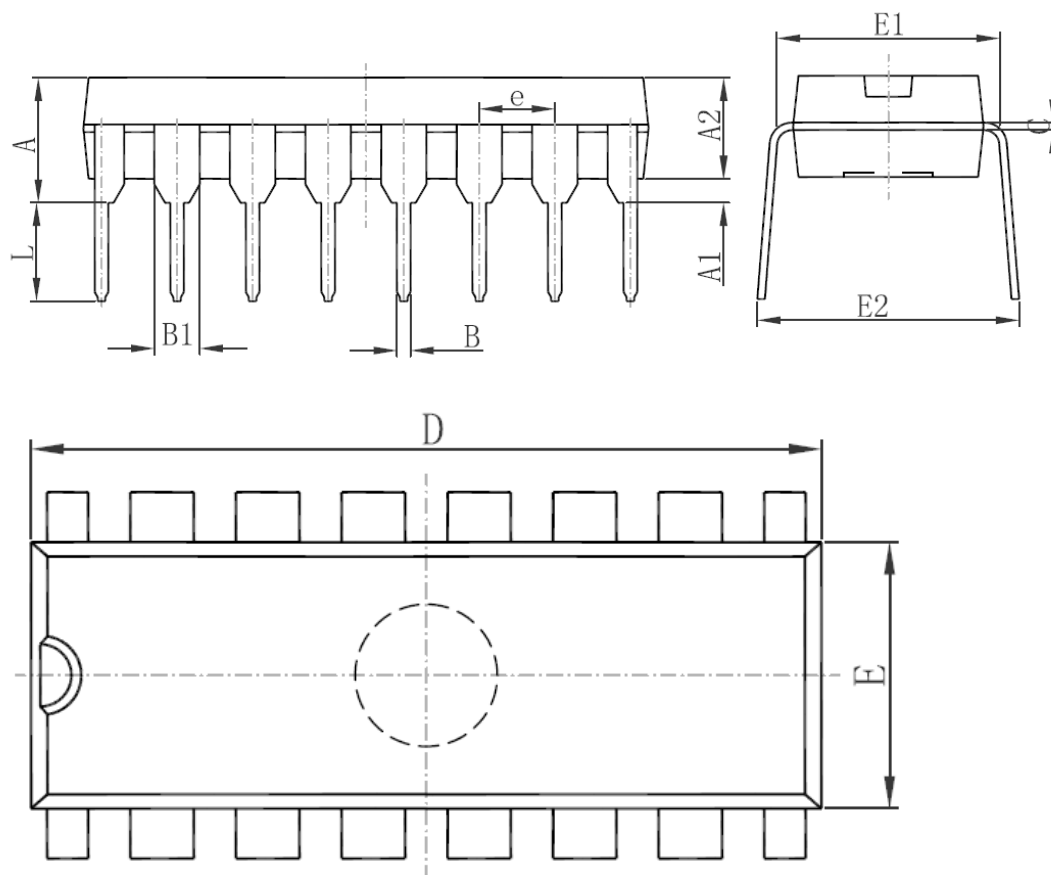

Symbol	Dimensions In Millimeters		Dimensions In Inches	
	Min	Max	Min	Max
A	3.710	4.310	0.146	0.170
A1	0.510		0.020	
A2	3.200	3.600	0.126	0.142
B	0.380	0.570	0.015	0.022
B1	1.524 (BSC)		0.060 (BSC)	
C	0.204	0.360	0.008	0.014
D	18.800	19.200	0.740	0.756
E	6.200	6.600	0.244	0.260
E1	7.320	7.920	0.288	0.312
e	2.540 (BSC)		0.100 (BSC)	
L	3.000	3.600	0.118	0.142
E2	8.400	9.000	0.331	0.354

ULN2003 series High -voltage High-current Darlington Transistor Arrays

SOP16 Outline Dimensions

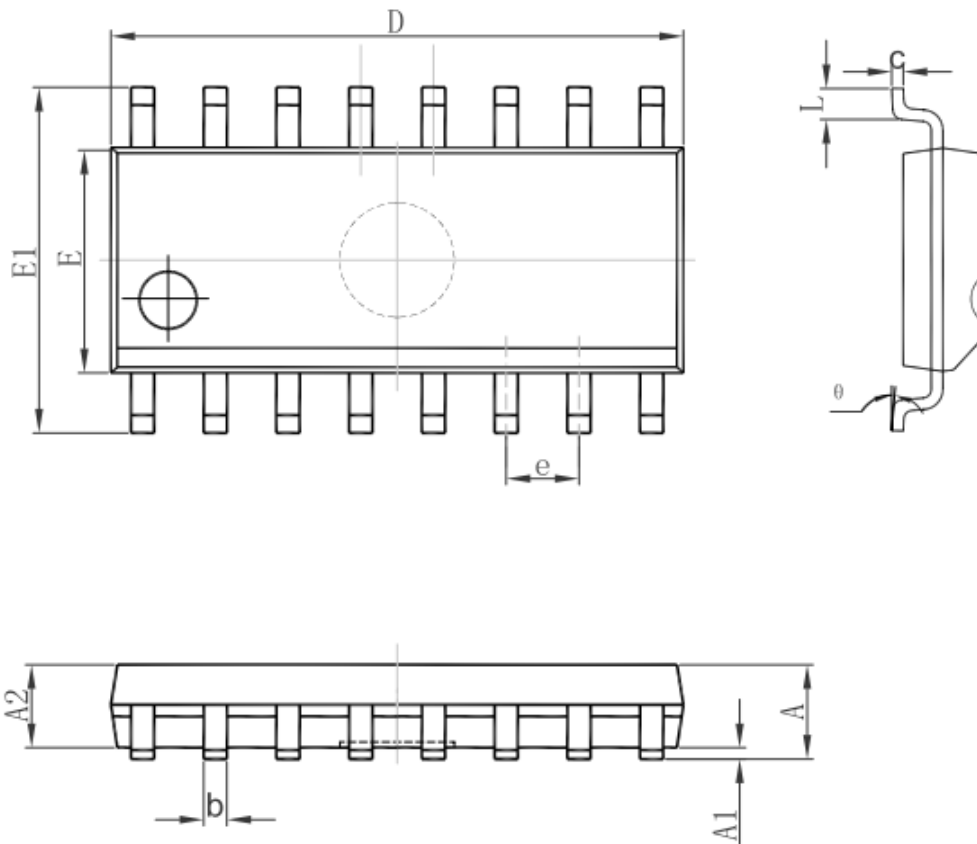

Symbol	Dimensions In Millimeters		Dimensions In Inches	
	Min	Max	Min	Max
A	1.350	1.750	0.053	0.069
A1	0.100	0.250	0.004	0.010
A2	1.350	1.550	0.053	0.061
b	0.330	0.510	0.013	0.020
c	0.170	0.250	0.007	0.010
D	9.800	10.200	0.386	0.402
E	3.800	4.000	0.150	0.157
E1	5.800	6.200	0.228	0.244
e	1.270 (BSC)		0.050 (BSC)	
L	0.400	1.270	0.016	0.050
θ	0°	8°	0°	8°

ULN2003 series High -voltage High-current Darlington Transistor Arrays

SSOP16 Outline Dimensions

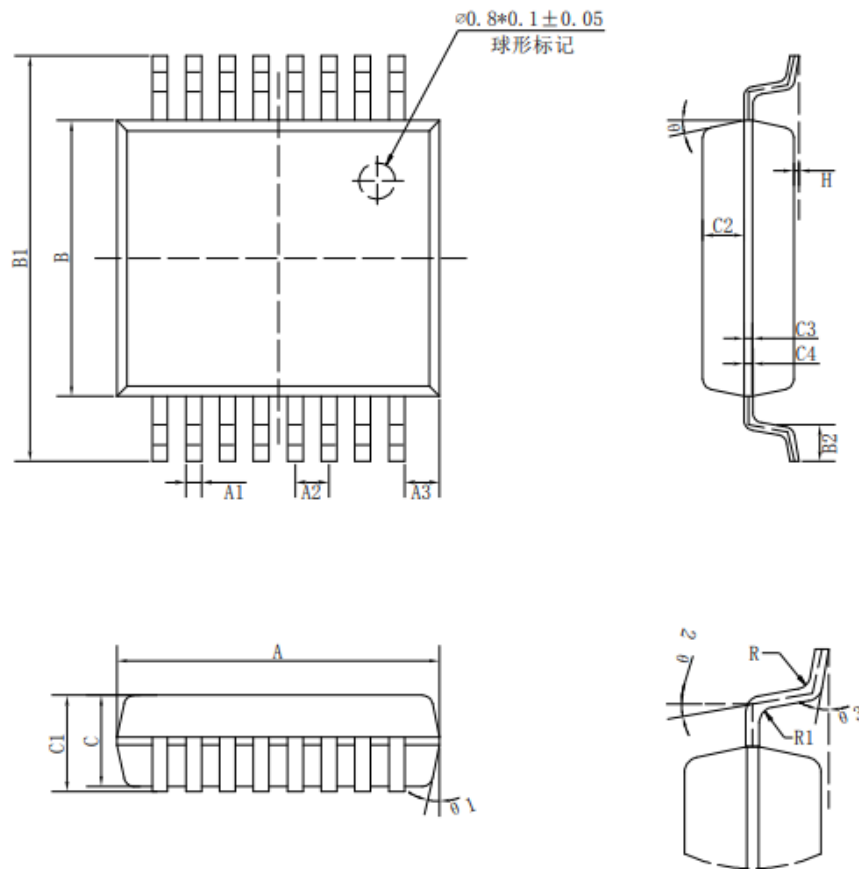

标注	尺寸	最小 (mm)	最大 (mm)	标注	尺寸	最小 (mm)	最大 (mm)
A		6.15	6.25	C3		0.152	
A1		0.30TYP		C4		0.172	
A2		0.65TYP		H		0.05	0.15
A3		0.675TYP		θ		12° TYP4	
B		5.25	5.35	$\theta 1$		12° TYP4	
B1		7.65	7.95	$\theta 2$		10° TYP	
B2		0.60	0.80	$\theta 3$		0° ~ 8°	
C		1.70	1.80	R		0.20TYP	
C1		1.75	1.95	R1		0.15TYP	
C2		0.799					

ULN2003 series High-voltage High-current Darlington Transistor Arrays

TSSOP16 Outline Dimensions

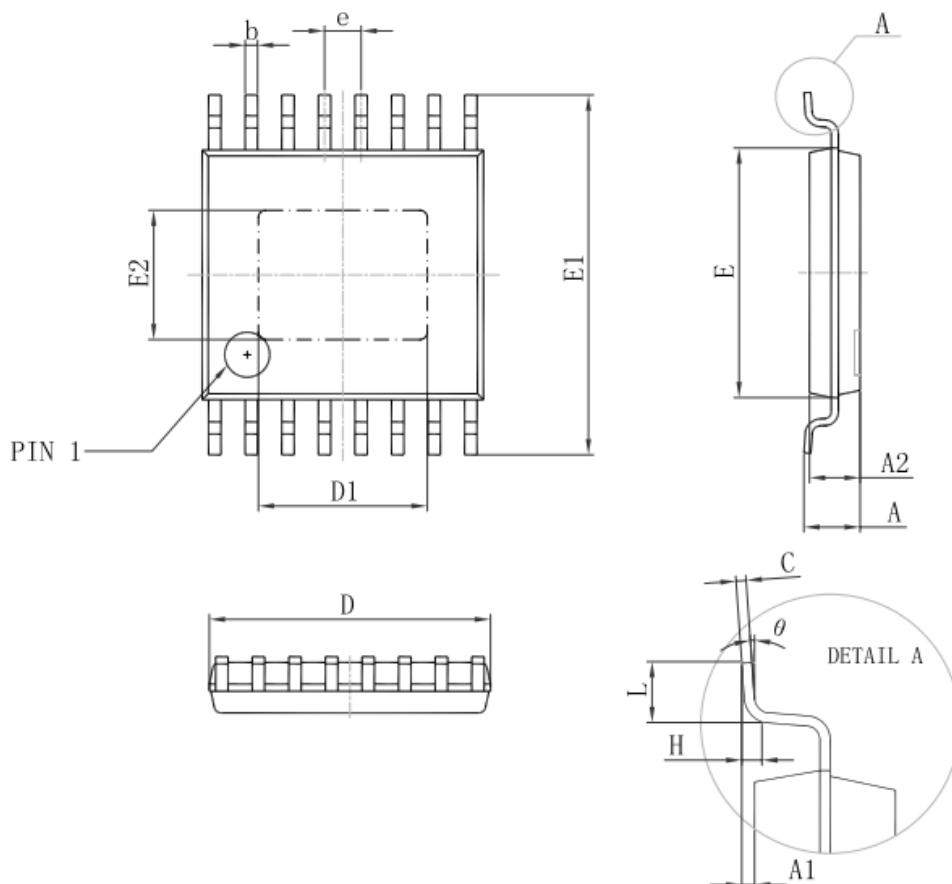

Symbol	Dimensions In Millimeters		Dimensions In Inches	
	Min	Max	Min	Max
D	4.900	5.100	0.193	0.201
D1	2.900	3.100	0.114	0.122
E	4.300	4.500	0.169	0.177
b	0.190	0.300	0.007	0.012
e	0.090	0.200	0.004	0.008
E1	6.250	6.550	0.246	0.258
E2	2.200	2.400	0.087	0.094
A		1.150		0.043
A2	0.800	1.000	0.031	0.039
A1	0.020	0.150	0.001	0.006
e	0.65 (BSC)		0.026 (BSC)	
L	0.500	0.700	0.02	0.028
H	0.25(TYP)		0.01(TYP)	
θ	1°	7°	1°	7°

X-ON Electronics

Largest Supplier of Electrical and Electronic Components

Click to view similar products for [Darlington Transistors](#) category:

Click to view products by [hengjiaxing](#) manufacturer:

Other Similar products are found below :

[BDV64B](#) [2N6298](#) [NJVMJD117T4G](#) [2N6053](#) [MPSA63](#) [NTE256](#) [TIP120](#) [MJ11028](#) [TIP127](#) [Jantx2N6352](#) [2N6301](#) [NJVBUB323ZT4G](#)
[ULN2803QN](#) [KID65004AF-EL/P](#) [ULN2803CDWR](#) [MJ11033G-JSM](#) [MMBTA64](#) [TPM2003-SO3R](#) [KSP13](#) [TIP127](#) [TIP122](#) [TIP122F](#)
[TIP122-JSM](#) [ULN2003A-JSM](#) [MJ11032G-JSM](#) [ULN2001D\(MS\)](#) [2SD1071](#) [TIP160](#) [2N6287](#) [MJ3001](#) [MJ2501](#) [ULN2001D\(UMW\)](#)
[ULN2003APWR\(UMW\)](#) [ULN2003AIPWR\(UMW\)](#) [ULN2002D\(UMW\)](#) [ULN2803G-P20-R](#) [WD2002](#) [AIP2003LSA16.TB](#) [AIP2803SA.TR](#)
[AIP2803](#) [AIP2803LSA18.TB](#) [XL2803CD](#) [ULN2004MT/TR](#) [MMBTA13](#) [MJD127](#) [MJD122](#) [ULN2003IPWRG](#) [ULN2803ADWMRG](#)
[MC1413DRG](#) [ULN2003LVDRG](#)