

65HVD7x 3.3-V Supply RS-485 With IEC ESD protection

Features

- Small-size VSSOP Packages Save Board Space, or SOIC for Drop-in Compatibility
- Bus I/O Protection
 - $>\pm 15$ kV HBM Protection
 - $>\pm 12$ kV IEC 61000-4-2 Contact Discharge
 - $>\pm 4$ kV IEC 61000-4-4 Fast Transient Burst
- Extended Industrial Temperature Range
 -40°C to 125°C
- Large Receiver Hysteresis (80 mV) for Noise Rejection
- Low Unit-Loading Allows Over 200 Connected Nodes
- Low Power Consumption
 - Low Standby Supply Current: $< 2 \mu\text{A}$
 - $I_{\text{CC}} < 1 \text{ mA}$ Quiescent During Operation
- 5-V Tolerant Logic Inputs Compatible With 3.3-V or 5-V Controllers
- Signaling Rate Options Optimized for:
 250 kbps, 20 Mbps, 50 Mbps
- Glitch Free Power-Up and Power-Down Bus Inputs and Outputs

Applications

- Factory Automation
- Telecommunications Infrastructure
- Motion Control

Description

These devices have robust 3.3-V drivers and receivers in a small package for demanding industrial applications. The bus pins are robust to ESD events with high levels of protection to Human-Body Model and IEC Contact Discharge specifications.

Each of these devices combines a differential driver and a differential receiver which operate from a single 3.3-V power supply. The driver differential outputs and the receiver differential inputs are connected internally to form a bus port suitable for half-duplex (two-wire bus) communication. These devices feature a wide common-mode voltage range making the devices suitable for multi-point applications over long cable runs. These devices are characterized from -40°C to 125°C .

Typical Application Diagram

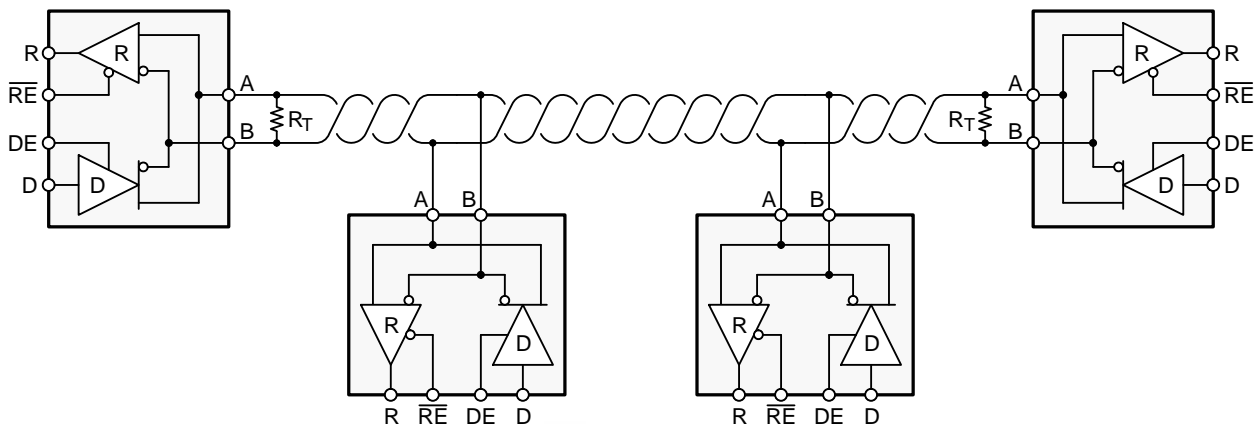

Pin Configuration and Functions

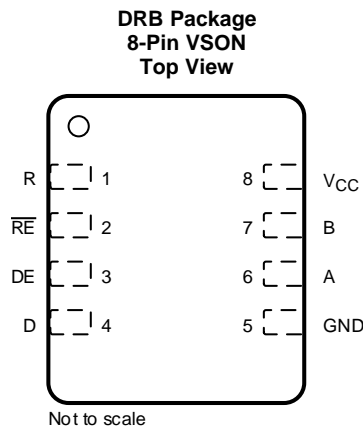
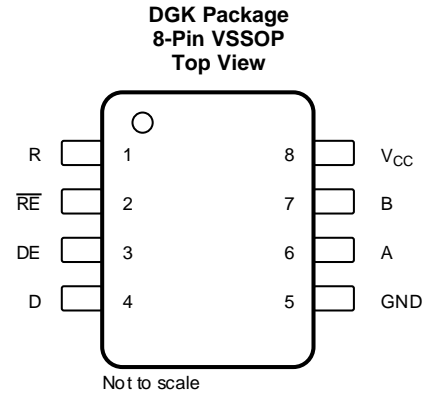
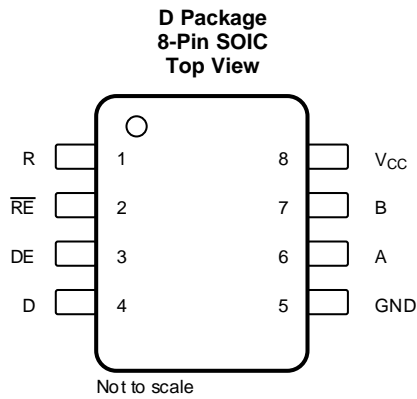

Pin Functions

PIN		TYPE	DESCRIPTION
NAME	NUMBER		
A	6	Bus I/O	Driver output or receiver input (complementary to B)
B	7	Bus I/O	Driver output or receiver input (complementary to A)
D	4	Digital input	Driver data input
DE	3	Digital input	Active-high driver enable
GND	5	Reference potential	Local device ground
R	1	Digital output	Receive data output
\overline{RE}	2	Digital input	Active-low receiver enable
V _{CC}	8	Supply	3-V to 3.6-V supply

Absolute Maximum Ratings

over recommended operating range (unless otherwise specified) ⁽¹⁾

	MIN	MAX	UNIT
Supply voltage, V_{CC}	-0.5	5	V
Voltage at A or B inputs	-13	16.5	
Voltage at D, DE, or \overline{RE}	-0.3	5.7	
Voltage input, transient pulse, A and B, through 100 Ω	-100	100	
Receiver output current	-24	24	mA
Junction temperature, T_J		170	°C
Continuous total power dissipation	See Power Dissipation		
Storage temperature, T_{stg}	-65	150	°C

- (1) Stresses beyond those listed under *Absolute Maximum Ratings* may cause permanent damage to the device. These are stress ratings only and functional operation of the device at these or any other conditions beyond those indicated under [Recommended Operating Conditions](#) is not implied. Exposure to absolute-maximum-rated conditions for extended periods may affect device reliability.

ESD Ratings

		VALUE	UNIT
$V_{(ESD)}$	Electrostatic discharge	Human body model (HBM), per ANSI/ESDA/JEDEC JS-001, all pins ⁽¹⁾	±8000
		Charged device model (CDM), per JEDEC specification JESD22-C101 or ANSI/ESDA/JEDEC JS-002, all pins ⁽²⁾	±1500
		JEDEC Standard 22, Test Method A115 (Machine Model), all pins	±300
		IEC 61000-4-2 ESD (Air-Gap Discharge), bus pins and GND ⁽³⁾	±12000
		IEC 61000-4-2 ESD (Contact Discharge), bus pins and GND	±12000
		IEC 61000-4-4 EFT (Fast transient or burst) bus pins and GND	±4000
		IEC 60749-26 ESD (Human Body Model), bus pins and GND	±15000

- (1) JEDEC document JEP155 states that 500-V HBM allows safe manufacturing with a standard ESD control process.
 (2) JEDEC document JEP157 states that 250-V CDM allows safe manufacturing with a standard ESD control process.
 (3) By inference from contact discharge results, see [Application and Implementation](#).

Recommended Operating Conditions

		MIN	NOM	MAX	UNIT
V_{CC} ⁽¹⁾	Supply voltage	3	3.3	3.6	V
V_I	Input voltage at any bus terminal (separately or common mode) ⁽²⁾	-7		12	V
V_{IH}	High-level input voltage (driver, driver enable, and receiver enable inputs)	2		V_{CC}	V
V_{IL}	Low-level input voltage (driver, driver enable, and receiver enable inputs)	0		0.8	V
V_{ID}	Differential input voltage	-12		12	V
I_O	Output current, driver	-60		60	mA
I_O	Output current, receiver	-8		8	mA
R_L	Differential load resistance	54	60		Ω
C_L	Differential load capacitance		50		pF
$1/t_{UI}$	Signaling rate	65HVD72		250	kbps
		65HVD75		20	Mbps
		65HVD78		50	Mbps
T_A ⁽³⁾	Operating free-air temperature (See Thermal Information)	-40		125	°C
T_J	Junction temperature	-40		150	°C

- (1) Exposure to conditions beyond the recommended operation maximum for extended periods may affect device reliability.
 (2) The algebraic convention, in which the least positive (most negative) limit is designated as minimum, is used in this data sheet.
 (3) Operation is specified for internal (junction) temperatures up to 150°C. Self-heating due to internal power dissipation should be considered for each application. Maximum junction temperature is internally limited by the thermal shutdown (TSD) circuit which disables the driver outputs when the junction temperature reaches 170°C.

Thermal Information

THERMAL METRIC ⁽¹⁾		65HVD72, 65HVD75, 65HVD78			UNIT
		D (SOIC)	DGK (VSSOP)	DRB (VSON)	
		8 PINS			
R _{θJA}	Junction-to-ambient thermal resistance	110.7	168.7	40	°C/W
R _{θJC(top)}	Junction-to-case (top) thermal resistance	54.7	62.2	49.6	°C/W
R _{θJC(bot)}	Junction-to-case (bottom) thermal resistance	—	—	3.9	°C/W
R _{θJB}	Junction-to-board thermal resistance	51.3	89.5	15.5	°C/W
ψ _{JT}	Junction-to-top characterization parameter	9.2	7.4	0.6	°C/W
ψ _{JB}	Junction-to-board characterization parameter	50.7	87.9	15.7	°C/W

(1) For more information about traditional and new thermal metrics, see the [Semiconductor and IC Package Thermal Metrics](#) application report.

Electrical Characteristics

over recommended operating range (unless otherwise specified)

PARAMETER	TEST CONDITIONS	MIN	TYP	MAX	UNIT	
V _{OD}	R _L = 60 Ω, 375 Ω on each output to -7 V to 12 V	See Figure 10	1.5	2	V	
	R _L = 54 Ω (RS-485)		1.5	2		
	R _L = 100 Ω (RS-422), T _J ≥ 0°C V _{CC} ≥ 3.2 V		2	2.5		
Δ V _{OD}	R _L = 54 Ω, C _L = 50 pF	-50	0	50	mV	
V _{OC(SS)}	Center of two 27-Ω load resistors	See Figure 11	1	V _{CC} /2	3	V
ΔV _{OC}	Center of two 27-Ω load resistors		-50	0	50	mV
V _{OC(PP)}	Center of two 27-Ω load resistors			200		mV
C _{OD}	Differential output capacitance		15		pF	
V _{IT+}	Positive-going receiver differential input voltage threshold	See ⁽¹⁾	-70	-20	mV	
V _{IT-}	Negative-going receiver differential input voltage threshold	-200	-150	See ⁽¹⁾	mV	
V _{HYS}	Receiver differential input voltage threshold hysteresis (V _{IT+} - V _{IT-})	50	80		mV	
V _{OH}	Receiver high-level output voltage	I _{OH} = -8 mA	2.4	V _{CC} - 0.3	V	
V _{OL}	Receiver low-level output voltage	I _{OL} = 8 mA		0.2	0.4	V
I _I	Driver input, driver enable, and receiver enable input current		-2	2	μA	
I _{OZ}	Receiver output high-impedance current	V _O = 0 V or V _{CC} , \overline{RE} at V _{CC}	-1	1	μA	
I _{OS}	Driver short-circuit output current		-160	160	mA	

Electrical Characteristics (continued)

over recommended operating range (unless otherwise specified)

PARAMETER		TEST CONDITIONS		MIN	TYP	MAX	UNIT	
I_i	Bus input current (disabled driver)	$V_{CC} = 3$ to 3.6 V or $V_{CC} = 0$ V DE at 0 V	65HVD72	$V_I = 12$ V		75	150	μA
			65HVD75	$V_I = -7$ V	-100	-40		
			65HVD78	$V_I = 12$ V		240	333	
				$V_I = -7$ V	-267	-180		
I_{CC}	Supply current (quiescent)	Driver and receiver enabled	DE = V_{CC} , $\overline{RE} = \text{GND}$ No load		750	950	μA	
			DE = V_{CC} , $\overline{RE} = V_{CC}$ No load		300	500		
			DE = GND, $\overline{RE} = \text{GND}$ No load		600	800		
			DE = GND, D = open $\overline{RE} = V_{CC}$, No load	0.1	2			
Supply current (dynamic)		See <i>Typical Characteristics</i>						
T_{TSD}	Thermal shutdown junction temperature				170		$^{\circ}\text{C}$	

Power Dissipation

PARAMETER		TEST CONDITIONS		VALUE	UNIT	
PD	Power Dissipation driver and receiver enabled, $V_{CC} = 3.6$ V, $T_J = 150^{\circ}\text{C}$ 50% duty cycle square-wave signal at signaling rate: <ul style="list-style-type: none"> 65HVD72 at 250 kbps 65HVD75 at 20 Mbps 65HVD78 at 50 Mbps 	Unterminated	$R_L = 300 \Omega$ $C_L = 50$ pF (driver)	65HVD72	120	mW
			65HVD75	160		
			65HVD78	200		
		RS-422 load	$R_L = 100 \Omega$ $C_L = 50$ pF (driver)	65HVD72	155	mW
				65HVD75	195	
				65HVD78	230	
		RS-485 load	$R_L = 54 \Omega$ $C_L = 50$ pF (driver)	65HVD72	190	mW
				65HVD75	230	
				65HVD78	260	

Switching Characteristics: 250 kbps Device (65HVD72) Bit Time $\geq 4 \mu\text{s}$

over recommended operating conditions

PARAMETER		TEST CONDITIONS		MIN	TYP	MAX	UNIT
DRIVER							
t_r, t_f	Driver differential output rise or fall time	$R_L = 54 \Omega$ $C_L = 50$ pF	See Figure 12	0.3	0.7	1.2	μs
t_{PHL}, t_{PLH}	Driver propagation delay				0.7	1	μs
$t_{SK(P)}$	Driver pulse skew, $ t_{PHL} - t_{PLH} $					0.2	μs
t_{PHZ}, t_{PLZ}	Driver disable time	Receiver enabled Receiver disabled	See Figure 13 and Figure 14		0.1	0.4	μs
t_{PZH}, t_{PZL}	Driver enable time				0.5	1	μs
				3	9		
RECEIVER							
t_r, t_f	Receiver output rise or fall time	$C_L = 15$ pF	See Figure 15		12	30	ns
t_{PHL}, t_{PLH}	Receiver propagation delay time				75	100	ns
$t_{SK(P)}$	Receiver pulse skew, $ t_{PHL} - t_{PLH} $				3	15	ns
t_{PLZ}, t_{PHZ}	Receiver disable time			40	100	ns	
$t_{PZL(1)}, t_{PZH(1)}, t_{PZL(2)}, t_{PZH(2)}$	Receiver enable time	Driver enabled	See Figure 16		20	50	ns
		Driver disabled	See Figure 17		3	8	μs

Switching Characteristics: 20 Mbps Device (65HVD75) Bit Time ≥ 50 ns

over recommended operating conditions

PARAMETER		TEST CONDITIONS		MIN	TYP	MAX	UNIT
DRIVER							
t_r, t_f	Driver differential output rise or fall time	$R_L = 54 \Omega$ $C_L = 50 \text{ pF}$	See Figure 12	2	7	14	ns
t_{PHL}, t_{PLH}	Driver propagation delay			7	11	17	ns
$t_{SK(P)}$	Driver pulse skew, $ t_{PHL} - t_{PLH} $				0	2	ns
t_{PHZ}, t_{PLZ}	Driver disable time				12	50	ns
t_{PZH}, t_{PZL}	Driver enable time	Receiver enabled	See Figure 13 and Figure 14		10	20	ns
		Receiver disabled			3	7	μs
RECEIVER							
t_r, t_f	Receiver output rise or fall time	$C_L = 15 \text{ pF}$	See Figure 15		5	10	ns
t_{PHL}, t_{PLH}	Receiver propagation delay time				60	70	ns
$t_{SK(P)}$	Receiver pulse skew, $ t_{PHL} - t_{PLH} $				0	6	ns
t_{PLZ}, t_{PHZ}	Receiver disable time				15	30	ns
$t_{pZL(1)}, t_{pZH(1)}, t_{pZL(2)}, t_{pZH(2)}$	Receiver enable time	Driver enabled	See Figure 16		10	50	ns
		Driver disabled	See Figure 17		3	8	μs

Switching Characteristics: 50 Mbps Device (65HVD78) Bit Time ≥ 20 ns

over recommended operating conditions

PARAMETER		TEST CONDITIONS		MIN	TYP	MAX	UNIT
DRIVER							
t_r, t_f	Driver differential output rise or fall time	$R_L = 54 \Omega$ $C_L = 50 \text{ pF}$	See Figure 12	1	3	6	ns
t_{PHL}, t_{PLH}	Driver propagation delay				9	15	ns
$t_{SK(P)}$	Driver pulse skew, $ t_{PHL} - t_{PLH} $				0	1	ns
t_{PHZ}, t_{PLZ}	Driver disable time				10	30	ns
t_{PZH}, t_{PZL}	Driver enable time	Receiver enabled	See Figure 13 and Figure 14		10	30	ns
		Receiver disabled				8	μs
RECEIVER							
t_r, t_f	Receiver output rise or fall time	$C_L = 15 \text{ pF}$	See Figure 15	1	3	6	ns
t_{PHL}, t_{PLH}	Receiver propagation delay time					35	ns
$t_{SK(P)}$	Receiver pulse skew, $ t_{PHL} - t_{PLH} $					2.5	ns
t_{PLZ}, t_{PHZ}	Receiver disable time				8	30	ns
$t_{pZL(1)}, t_{pZH(1)}, t_{pZL(2)}, t_{pZH(2)}$	Receiver enable time	Driver enabled	See Figure 16		10	30	ns
		Driver disabled	See Figure 17		3	8	μs

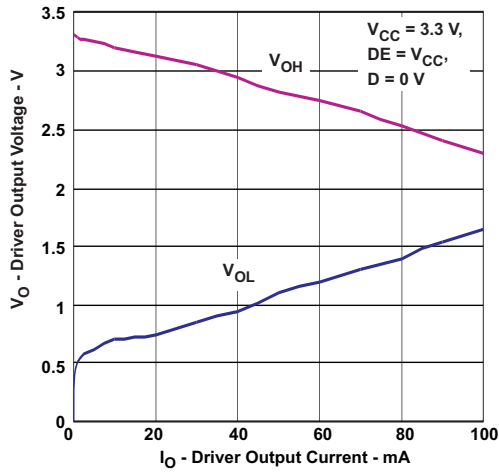
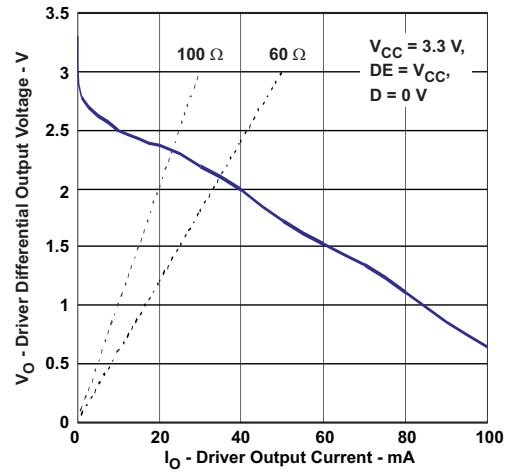
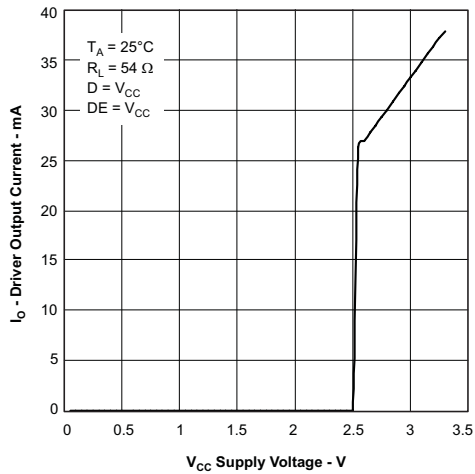
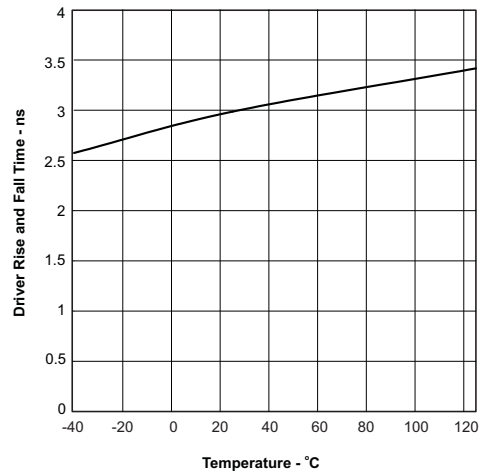
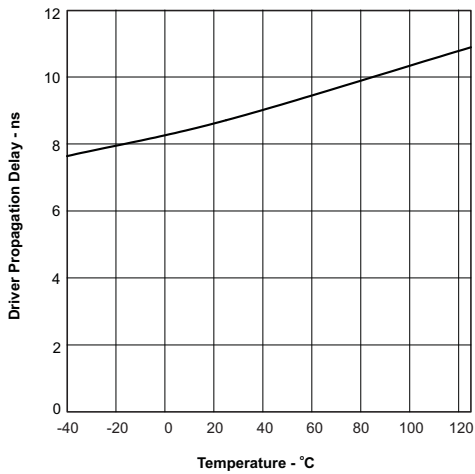
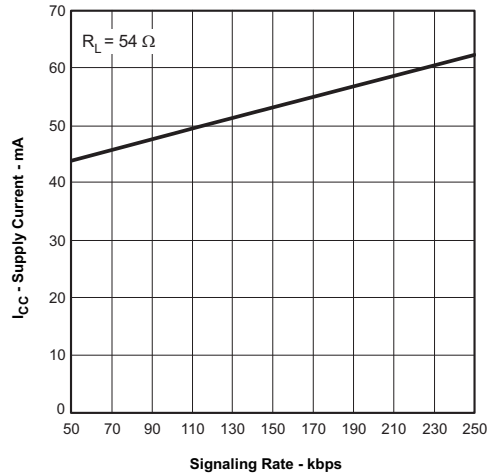
Typical Characteristics

Figure 1. Driver Output Voltage vs Driver Output Current

Figure 2. Driver Differential Output Voltage vs Driver Output Current

Figure 3. Driver Output Current vs Supply Voltage

Figure 4. 65HVD78 Driver Rise or Fall Time vs Temperature

Figure 5. 65HVD78 Driver Propagation Delay vs Temperature

Figure 6. 65HVD72 Supply Current vs Signal Rate

Typical Characteristics (continued)

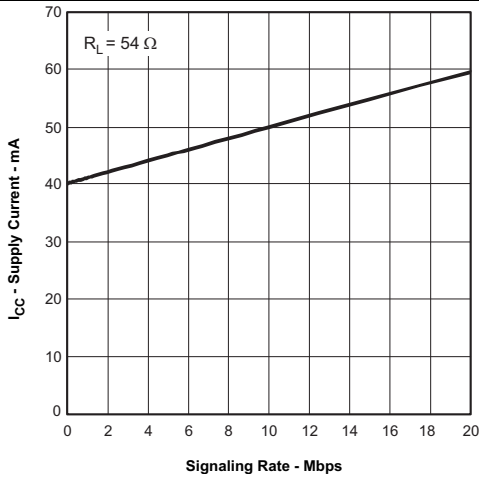

Figure 7. 65HVD75 Supply Current vs Signal Rate

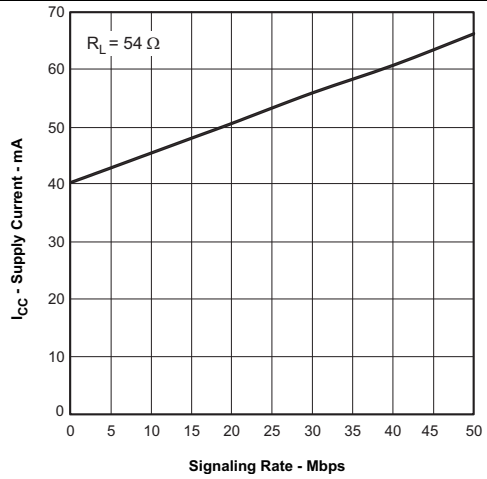

Figure 8. 65HVD78 Supply Current vs Signal Rate

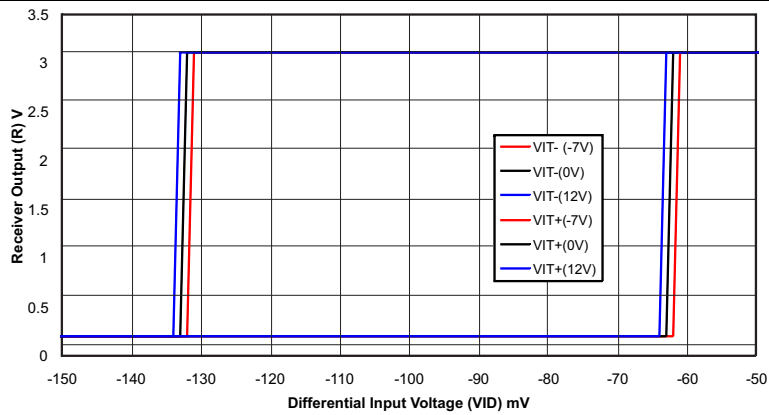
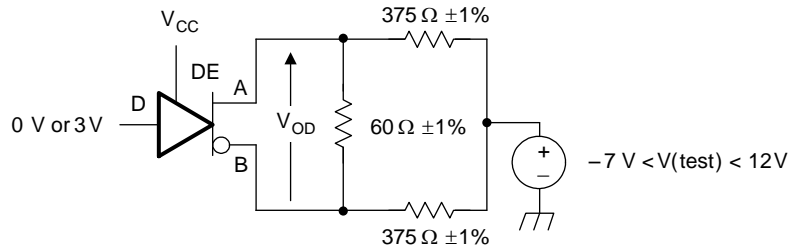
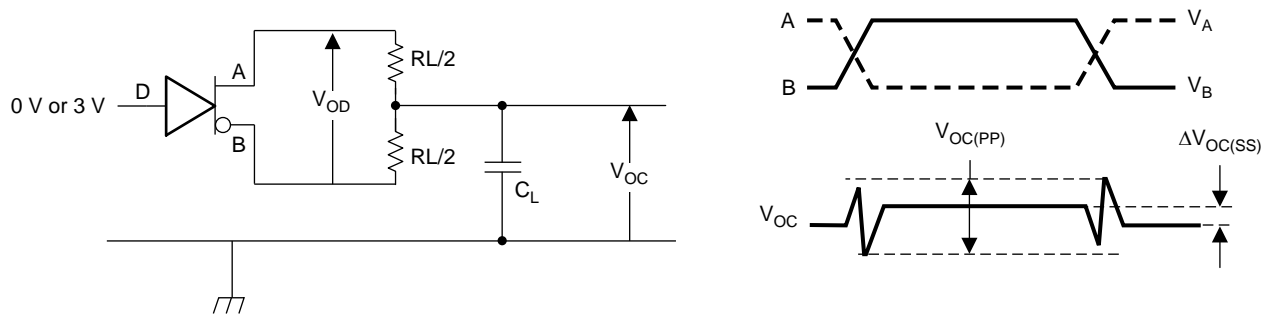
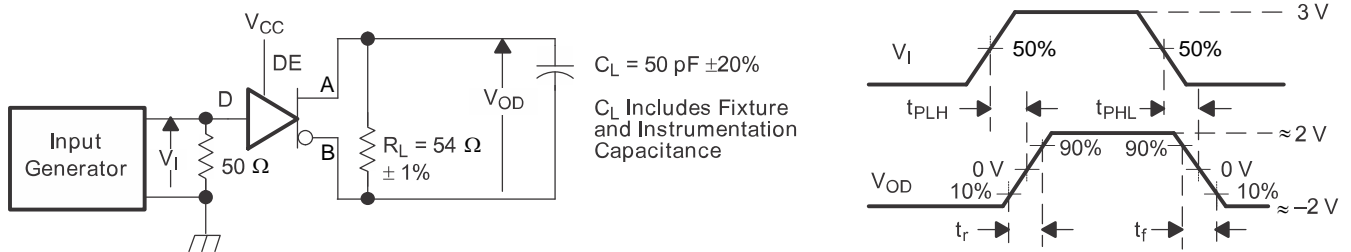
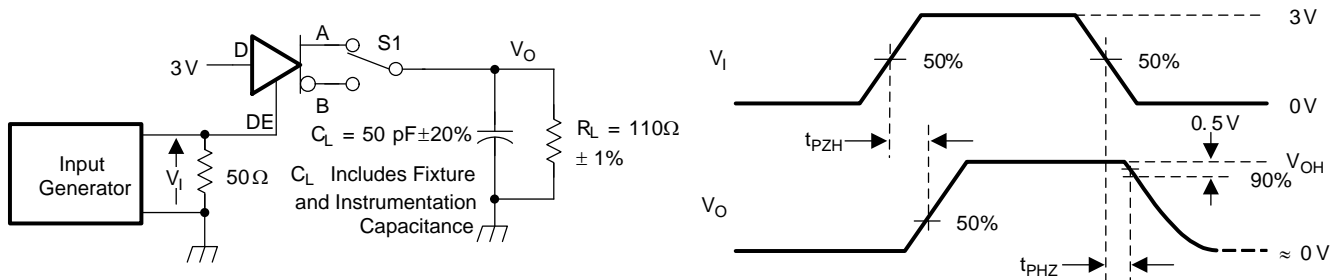

Figure 9. Receiver Output vs Input

Parameter Measurement Information

Input generator rate is 100 kbps, 50% duty cycle, rise or fall time is less than 6 ns, output impedance is 50 Ω .

Figure 10. Measurement of Driver Differential Output Voltage With Common-Mode Load

Figure 11. Measurement of Driver Differential and Common-Mode Output With RS-485 Load

Figure 12. Measurement of Driver Differential Output Rise and Fall Times and Propagation Delays

D at 3 V to test non-inverting output, D at 0 V to test inverting output.

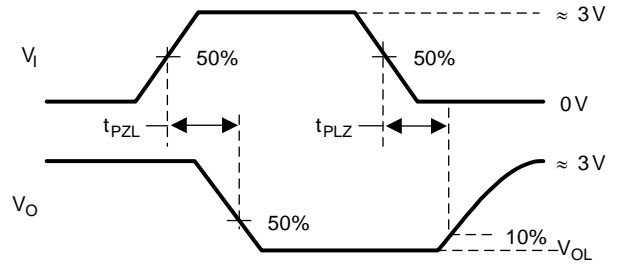
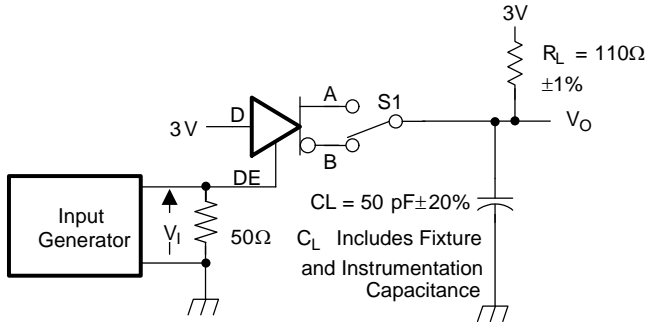
Figure 13. Measurement of Driver Enable and Disable Times With Active High Output and Pulldown Load

Parameter Measurement Information (continued)



D at 0 V to test non-inverting output, D at 3 V to test inverting output.

Figure 14. Measurement of Driver Enable and Disable Times With Active Low Output and Pullup Load

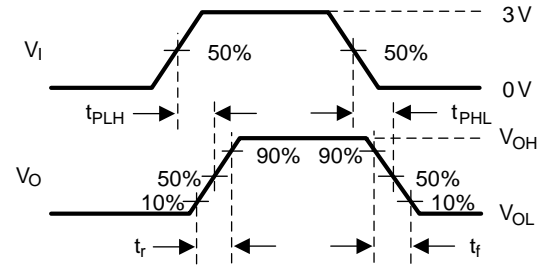
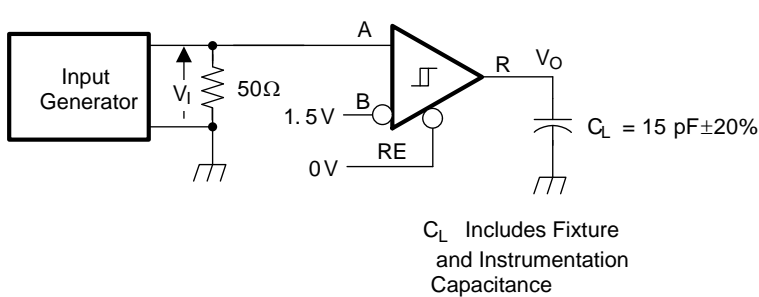

Figure 15. Measurement of Receiver Output Rise and Fall Times and Propagation Delays

Parameter Measurement Information (continued)

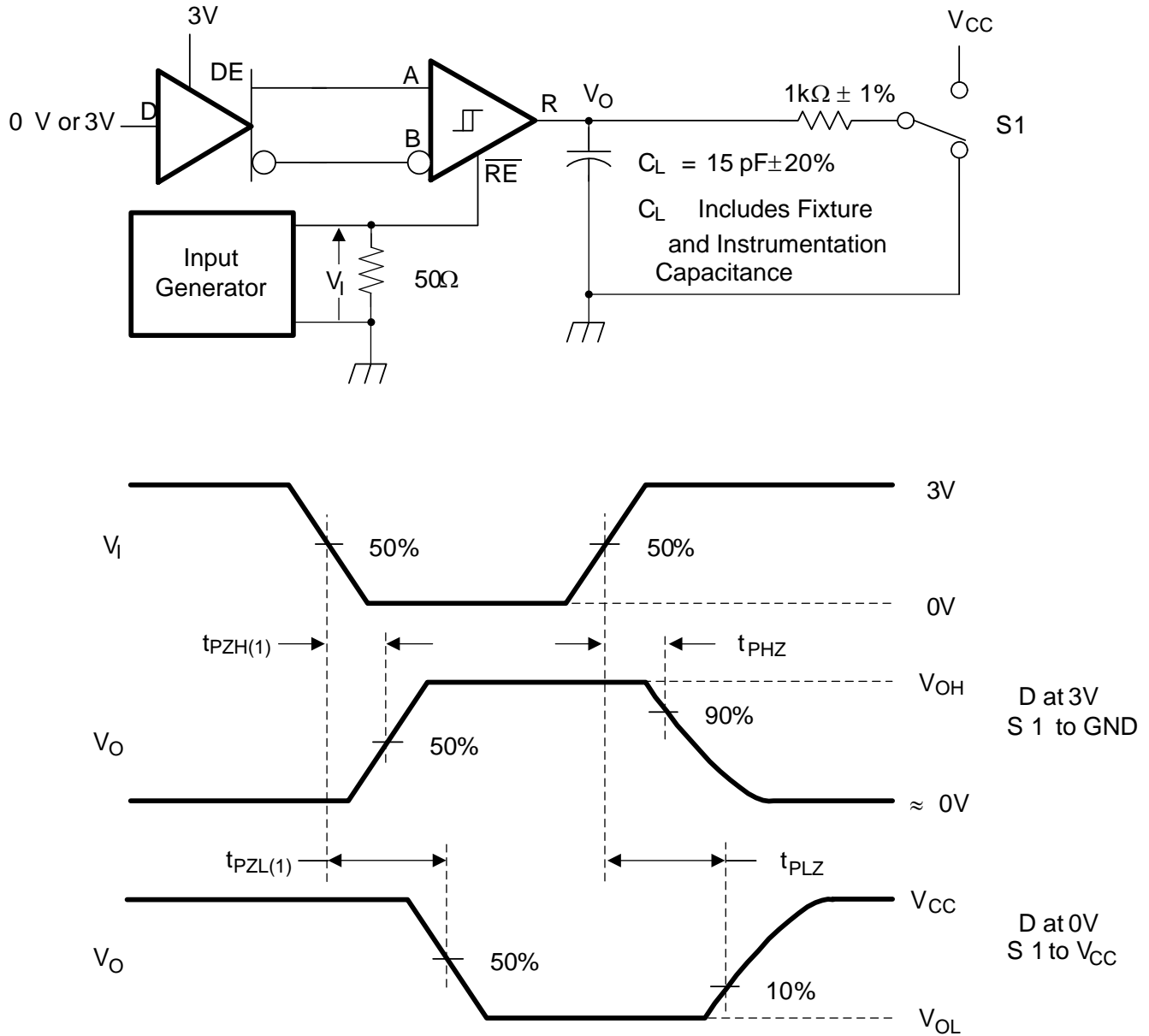

Figure 16. Measurement of Receiver Enable and Disable Times With Driver Enabled

Parameter Measurement Information (continued)

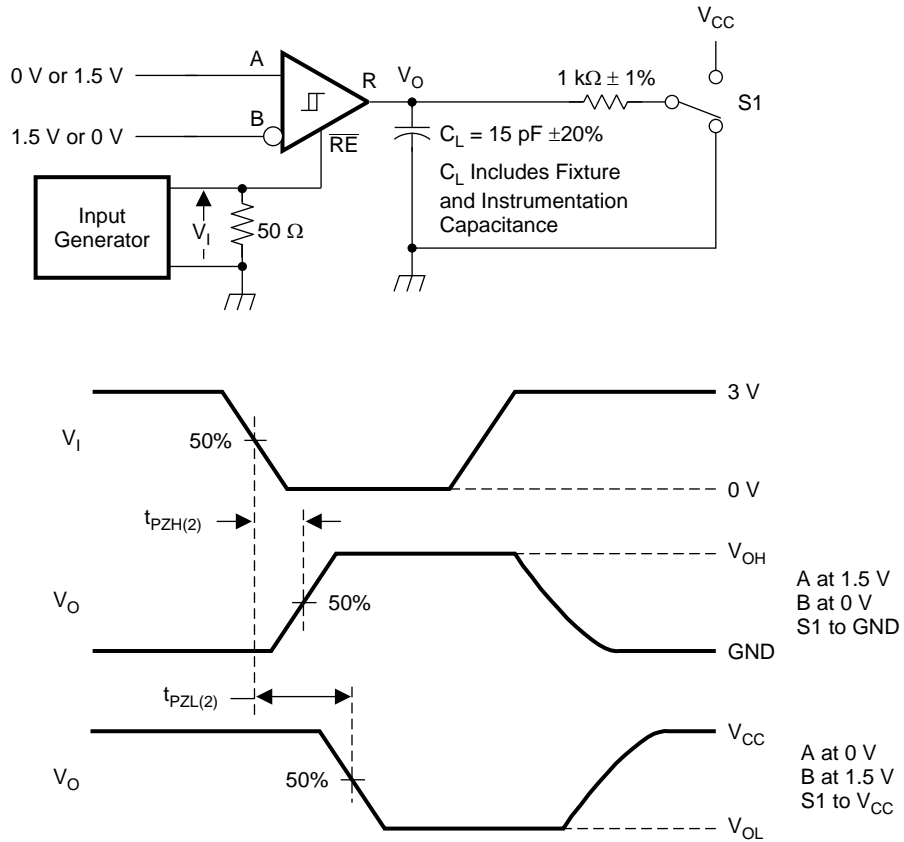

Figure 17. Measurement of Receiver Enable Times With Driver Disabled

Detailed Description

Overview

The 65HVD72, 65HVD75, and 65HVD78 are low-power, half-duplex RS-485 transceivers available in 3 speed grades suitable for data transmission up to 250 kbps, 20 Mbps, and 50 Mbps.

These devices have active-high driver enables and active-low receiver enables. A standby current of less than 2 μ A can be achieved by disabling both driver and receiver.

Functional Block Diagram

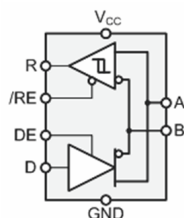

Feature Description

Internal ESD protection circuits protect the transceiver against electrostatic discharges (ESD) according to IEC 61000-4-2 of up to ± 12 kV, and against electrical fast transients (EFT) according to IEC 61000-4-4 of up to ± 4 kV.

The 65HVD7x half-duplex family provides internal biasing of the receiver input thresholds in combination with large input threshold hysteresis. At a positive input threshold of $V_{IT+} = -20$ mV and an input hysteresis of $V_{HYS} = 50$ mV, the receiver output remains logic high under a bus-idle or bus-short condition even in the presence of 140-mV_{PP} differential noise without the need for external failsafe biasing resistors.

Device operation is specified over a wide ambient temperature range from -40°C to 125°C .

Device Functional Modes

When the driver enable pin, DE, is logic high, the differential outputs A and B follow the logic states at data input D. A logic high at D causes A to turn high and B to turn low. In this case the differential output voltage defined as $V_{OD} = V_A - V_B$ is positive. When D is low, the output states reverse, B turns high, A becomes low, and V_{OD} is negative.

When DE is low, both outputs turn high-impedance. In this condition the logic state at D is irrelevant. The DE pin has an internal pulldown resistor to ground; thus, when left open, the driver is disabled (high-impedance) by default. The D pin has an internal pullup resistor to V_{CC} ; thus, when left open while the driver is enabled, output A turns high and B turns low.

Table 1. Driver Function Table

INPUT	ENABLE	OUTPUTS		DESCRIPTION
		A	B	
H	H	H	L	Actively drive bus high
L	H	L	H	Actively drive bus low
X	L	Z	Z	Driver disabled
X	OPEN	Z	Z	Driver disabled by default
OPEN	H	H	L	Actively drive bus high by default

When the receiver enable pin, \overline{RE} , is logic low, the receiver is enabled. When the differential input voltage defined as $V_{ID} = V_A - V_B$ is positive and higher than the positive input threshold, V_{IT+} , the receiver output, R, turns high. When V_{ID} is negative and lower than the negative input threshold, V_{IT-} , the receiver output turns low. If V_{ID} is between V_{IT+} and V_{IT-} , the output is indeterminate.

When \overline{RE} is logic high or left open, the receiver output is high-impedance and the magnitude and polarity of V_{ID} are irrelevant. Internal biasing of the receiver inputs causes the output to go failsafe-high when the transceiver is disconnected from the bus (open-circuit), the bus lines are shorted (short-circuit), or the bus is not actively driven (idle bus).

Table 2. Receiver Function Table

DIFFERENTIAL INPUT	ENABLE	OUTPUT	DESCRIPTION
$V_{ID} = V_A - V_B$	\overline{RE}	R	
$V_{IT+} < V_{ID}$	L	H	Receive valid bus high
$V_{IT-} < V_{ID} < V_{IT+}$	L	?	Indeterminate bus state
$V_{ID} < V_{IT-}$	L	L	Receive valid bus low
X	H	Z	Receiver disabled
X	OPEN	Z	Receiver disabled by default
Open-circuit bus	L	H	Failsafe high output
Short-circuit bus	L	H	Failsafe high output
Idle (terminated) bus	L	H	Failsafe high output

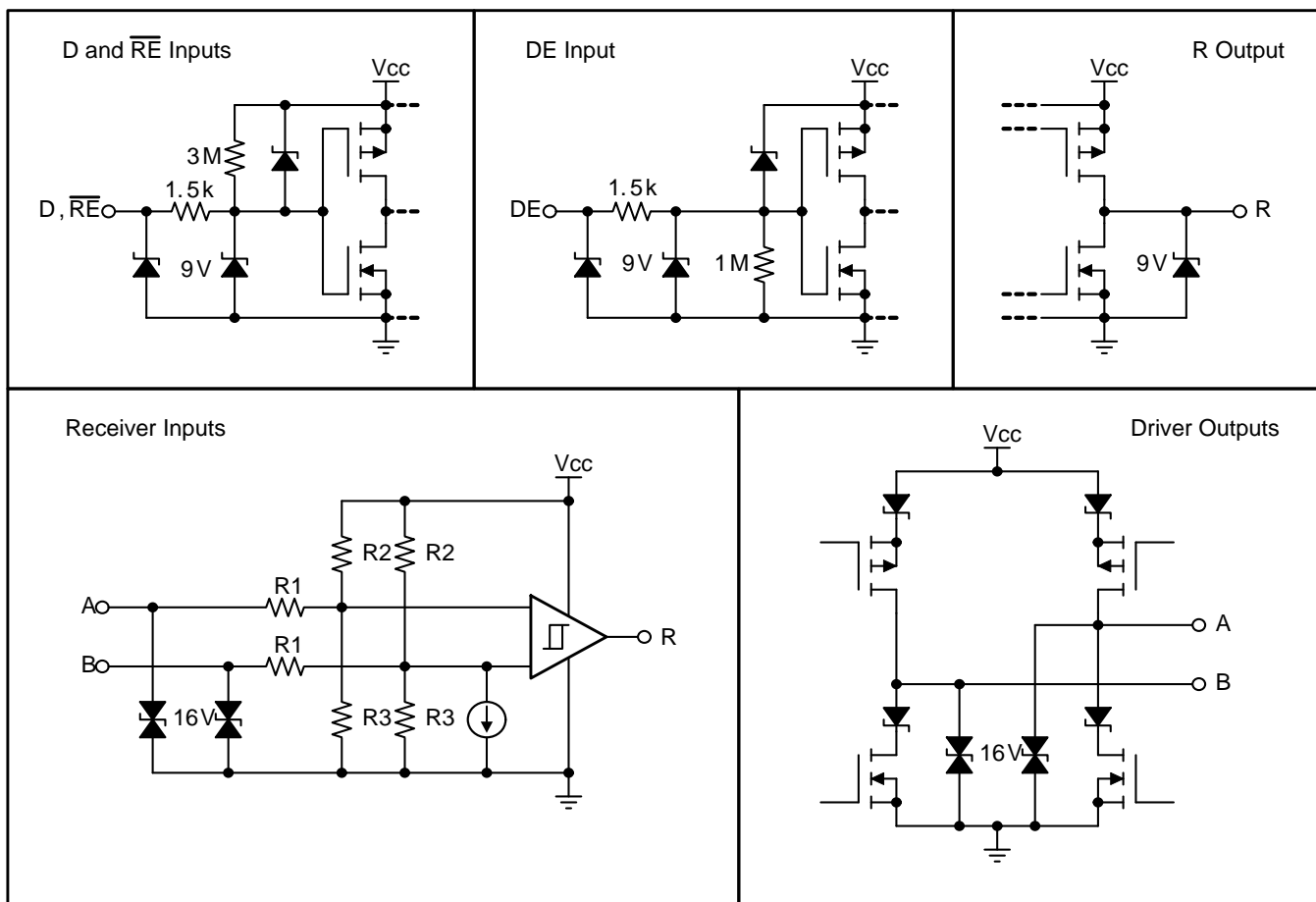

Figure 18. Equivalent Input and Output Circuit Diagrams

Application Information

The 65HVD72, 65HVD75, and 65HVD78 are half-duplex RS-485 transceivers commonly used for asynchronous data transmission. The driver and receiver enable pins allow for the configuration of different operating modes.

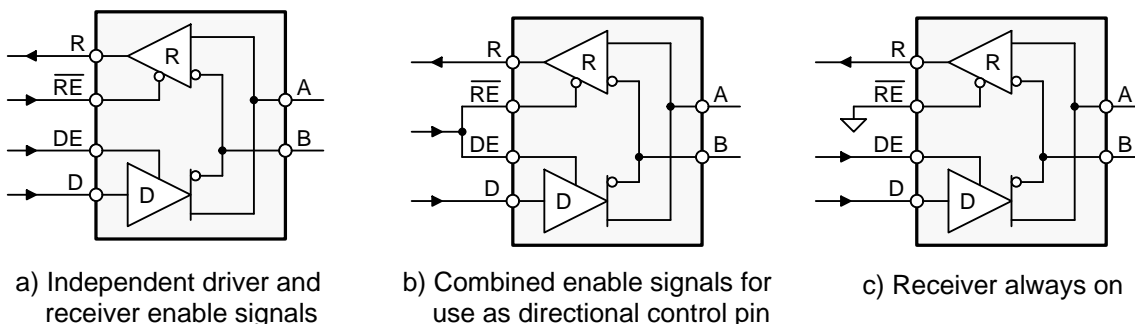

Figure 19. Transceiver Configurations

Using independent enable lines provides the most flexible control as it allows for the driver and the receiver to be turned on and off individually. While this configuration requires two control lines, it allows for selective listening into the bus traffic, whether the driver is transmitting data or not.

Combining the enable signals simplifies the interface to the controller by forming a single direction-control signal. In this configuration, the transceiver operates as a driver when the direction-control line is high, and as a receiver when the direction-control line is low.

Additionally, only one line is required when connecting the receiver-enable input to ground and controlling only the driver-enable input. In this configuration, a node not only receives the data from the bus, but also the data it sends and can verify that the correct data have been transmitted.

Typical Application

An RS-485 bus consists of multiple transceivers connected in parallel to a bus cable. To eliminate line reflections, each cable end is terminated with a termination resistor, R_T , whose value matches the characteristic impedance, Z_0 , of the cable. This method, known as parallel termination, allows for relatively high data rates over long cable lengths.

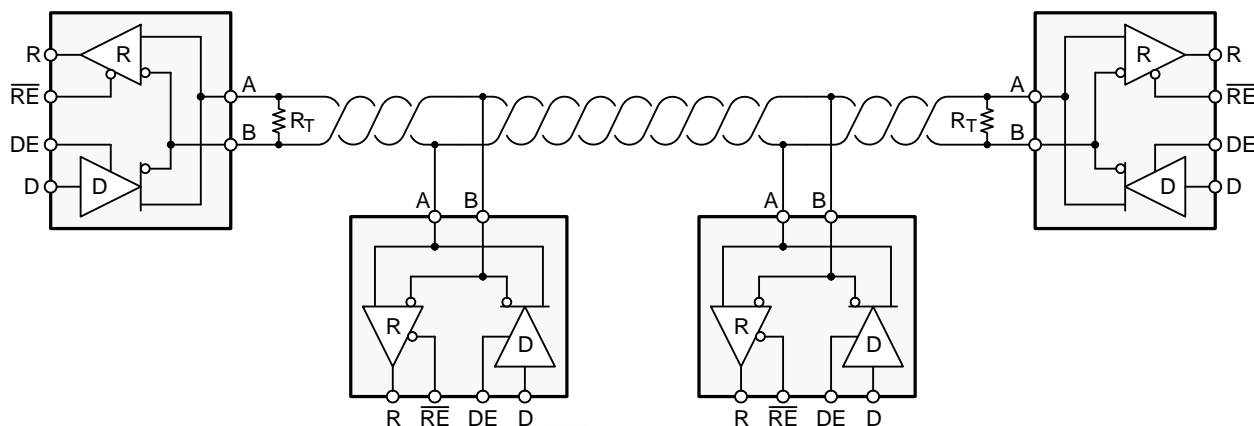

Figure 20. Typical RS-485 Network With 65HVD7x Transceivers

Common cables used are unshielded twisted pair (UTP), such as low-cost CAT-5 cable with $Z_0 = 100 \Omega$, and RS-485 cable with $Z_0 = 120 \Omega$. Typical cable sizes are AWG 22 and AWG 24.

The maximum bus length is typically given as 4000 ft or 1200 m, and represents the length of an AWG 24 cable whose cable resistance approaches the value of the termination resistance, thus reducing the bus signal by half or 6 dB. Actual maximum usable cable length depends on the signaling rate, cable characteristics, and environmental conditions.

Design Requirements

RS-485 is a robust electrical standard suitable for long-distance networking that may be used in a wide range of applications with varying requirements, such as distance, data rate, and number of nodes.

Data Rate and Bus Length

There is an inverse relationship between data rate and bus length, meaning the higher the data rate, the shorter the cable length; and conversely, the lower the data rate, the longer the cable may be without introducing data errors. While most RS-485 systems use data rates between 10 kbps and 100 kbps, some applications require data rates up to 250 kbps at distances of 4000 feet and longer. Longer distances are possible by allowing for small signal jitter of up to 5 or 10%.

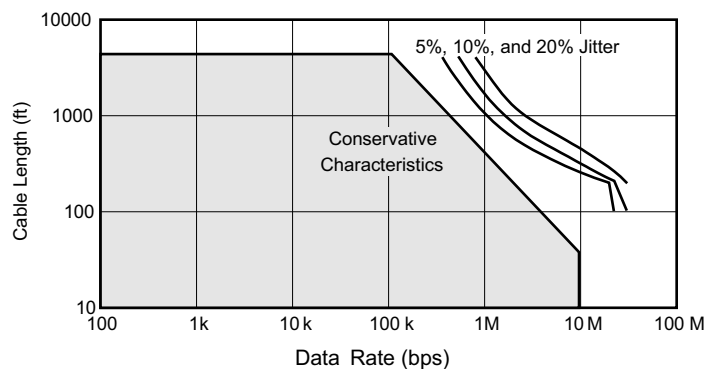

Figure 21. Cable Length vs Data Rate Characteristic

Typical Application (continued)

Stub Length

When connecting a node to the bus, the distance between the transceiver inputs and the cable trunk, known as the stub, should be as short as possible. Stubs present a non-terminated piece of bus line which can introduce reflections as the length of the stub increases. As a general guideline, the electrical length, or round-trip delay, of a stub should be less than one-tenth of the rise time of the driver, thus giving a maximum physical stub length as shown in [Equation 1](#).

$$L_{\text{stub}} \leq 0.1 \times t_r \times v \times c$$

where:

- t_r is the 10/90 rise time of the driver
 - c is the speed of light (3×10^8 m/s)
 - v is the signal velocity of the cable or trace as a factor of c
- (1)

Per [Equation 1](#) [Table 3](#) shows the maximum cable-stub lengths for the minimum driver output rise times of the 65HVD7x half-duplex family of transceivers for a signal velocity of 78%.

Table 3. Maximum Stub Length

DEVICE	MINIMUM DRIVER OUTPUT RISE TIME (ns)	MAXIMUM STUB LENGTH	
		(m)	(ft)
65HVD72	300	7	23
65HVD75	2	0.05	0.16
65HVD78	1	0.025	0.08

Bus Loading

The RS-485 standard specifies that a compliant driver must be able to drive 32 unit loads (UL), where 1 unit load represents a receiver input current of 1 mA at 12 V, or a load impedance of approximately 12 kΩ. Because the 65HVD72 and 65HVD75 have a receiver input current of 150 μA at 12 V, they are 3/20 UL transceivers, and no more than 213 transceivers should be connected to the bus. Similarly, the 65HVD78 has a receiver input current of 333 μA at 12 V and is a 1/3 UL transceiver, meaning no more than 96 transceivers should be connected to the bus.

Receiver Failsafe

The differential receiver is failsafe to invalid bus states caused by:

- Open bus conditions such as a disconnected connector
- Shorted bus conditions such as cable damage shorting the twisted-pair together, or
- Idle bus conditions that occur when no driver on the bus is actively driving

In any of these cases, the differential receiver will output a failsafe logic high so that the output of the receiver is not indeterminate.

Receiver failsafe is accomplished by offsetting the receiver thresholds such that the input-indeterminate range does not include zero volts differential. To comply with the RS-422 and RS-485 standards, the receiver output must output a high when the differential input V_{ID} is more positive than 200 mV, and must output a low when V_{ID} is more negative than -200 mV. The receiver parameters which determine the failsafe performance are V_{IT+} , V_{IT-} , and V_{HYS} (the separation between V_{IT+} and V_{IT-}). As shown in [Electrical Characteristics](#), differential signals more negative than -200 mV will always cause a low receiver output, and differential signals more positive than 200 mV will always cause a high receiver output.

When the differential input signal is close to zero, it is still above the maximum V_{IT+} threshold of -20 mV, and the receiver output will be high. Only when the differential input is more than V_{HYS} below V_{IT+} will the receiver output transition to a low state. Therefore, the noise immunity of the receiver inputs during a bus fault condition includes the receiver hysteresis value, V_{HYS} , as well as the value of V_{IT+} .

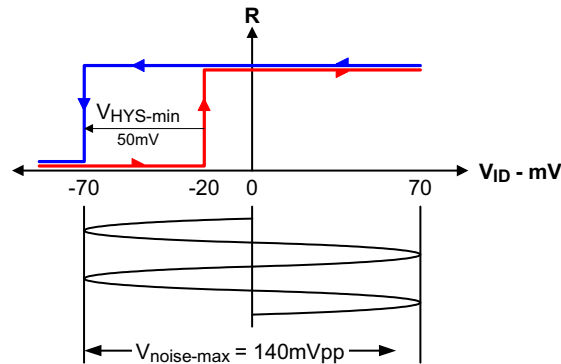

Figure 22. 65HVD7x Noise Immunity

Transient Protection

The bus pins of the 65HVD7x transceiver family possess on-chip ESD protection against ± 15 -kV human body model (HBM) and ± 12 -kV IEC 61000-4-2 contact discharge. The IEC-ESD test is far more severe than the HBM-ESD test. The 50% higher charge capacitance, C_S , and 78% lower discharge resistance, R_D , of the IEC-model produce significantly higher discharge currents than the HBM-model.

As stated in the IEC 61000-4-2 standard, contact discharge is the preferred test method; although IEC air-gap testing is less repeatable than contact testing, air discharge protection levels are inferred from the contact discharge test results.

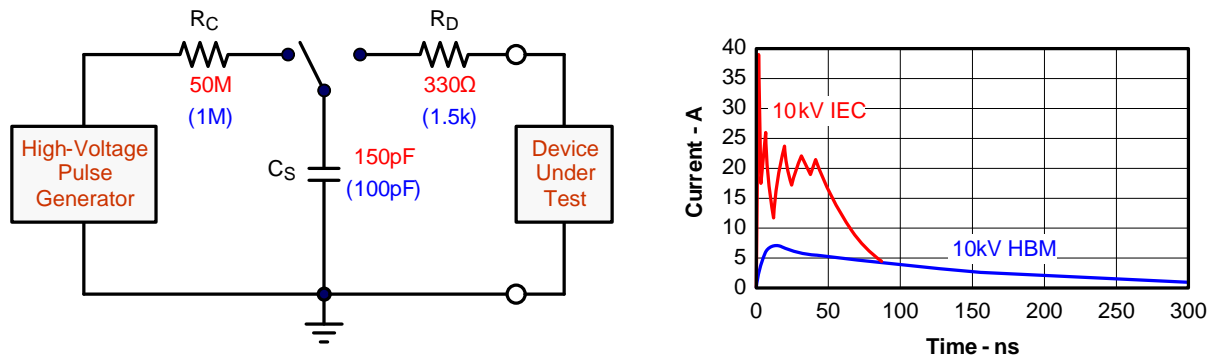

Figure 23. HBM and IEC-ESD Models and Currents in Comparison (HBM Values in Parenthesis)

The on-chip implementation of IEC ESD protection significantly increases the robustness of equipment. Common discharge events occur due to human contact with connectors and cables. Designers may choose to implement protection against longer duration transients, typically referred to as surge transients.

EFTs are generally caused by relay-contact bounce or the interruption of inductive loads. Surge transients often result from lightning strikes (direct strike or an indirect strike which induce voltages and currents), or the switching of power systems, including load changes and short circuit switching. These transients are often encountered in industrial environments, such as factory automation and power-grid systems.

Figure 24 compares the pulse-power of the EFT and surge transients with the power caused by an IEC ESD transient. The left-hand diagram shows the relative pulse-power for a 0.5-kV surge transient and 4-kV EFT transient, both of which dwarf the 10-kV ESD transient visible in the lower-left corner. 500-V surge transients are representative of events that may occur in factory environments in industrial and process automation.

The right-hand diagram shows the pulse-power of a 6-kV surge transient, relative to the same 0.5-kV surge transient. 6-kV surge transients are most likely to occur in power generation and power-grid systems.

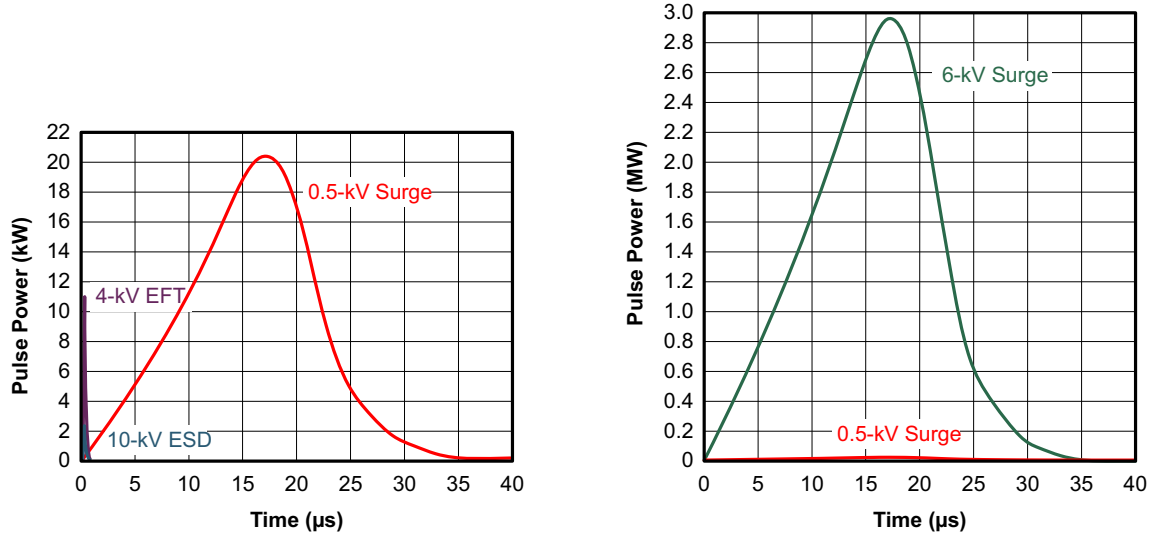

Figure 24. Power Comparison of ESD, EFT, and Surge Transients

In the case of surge transients, high-energy content is characterized by long pulse duration and slow decaying pulse power. The electrical energy of a transient that is dumped into the internal protection cells of a transceiver is converted into thermal energy which heats and destroys the protection cells, thus destroying the transceiver. Figure 25 shows the large differences in transient energies for single ESD, EFT, and surge transients, as well as for an EFT pulse train, commonly applied during compliance testing.

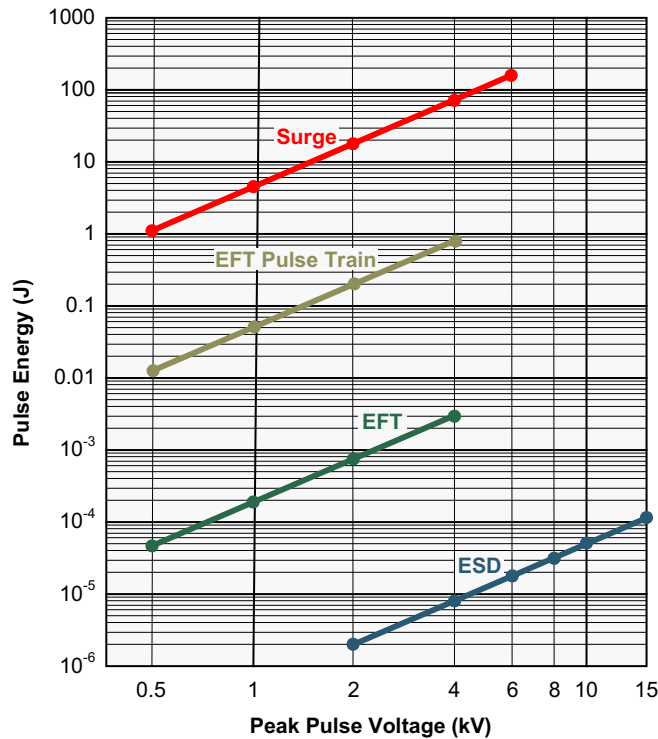

Figure 25. Comparison of Transient Energies

Detailed Design Procedure

External Transient Protection

To protect bus nodes against high-energy transients, the implementation of external transient protection devices is necessary. Figure 26 suggests two circuits that provide protection against light and heavy surge transients, in addition to ESD and EFT transients.

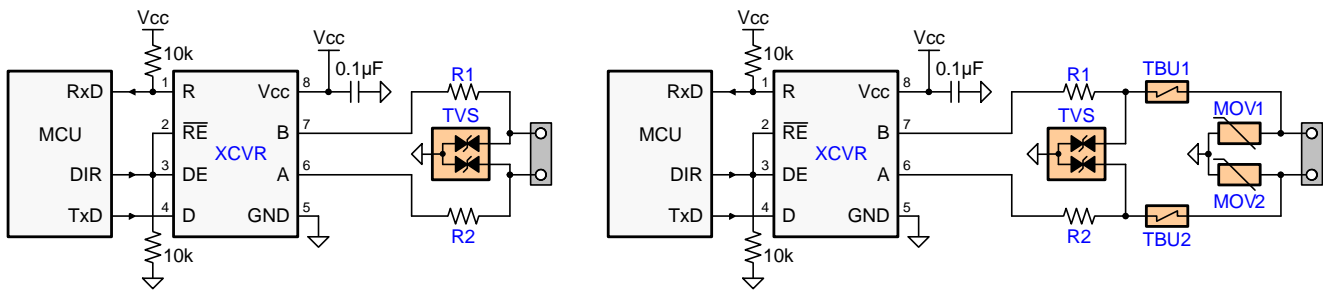

Figure 26. Transient Protections Against ESD, EFT, and Surge Transients

The left-hand circuit provides surge protection of $\geq 500\text{-V}$ surge transients, while the right-hand circuit can withstand surge transients of up to 5 kV.

10.2.2.2 Isolated Bus Node Design

Many RS-485 networks use isolated bus nodes to prevent the creation of unintended ground loops and their disruptive impact on signal integrity. An isolated bus node typically includes a microcontroller that connects to the bus transceiver via a multi-channel, digital isolator (Figure 27).

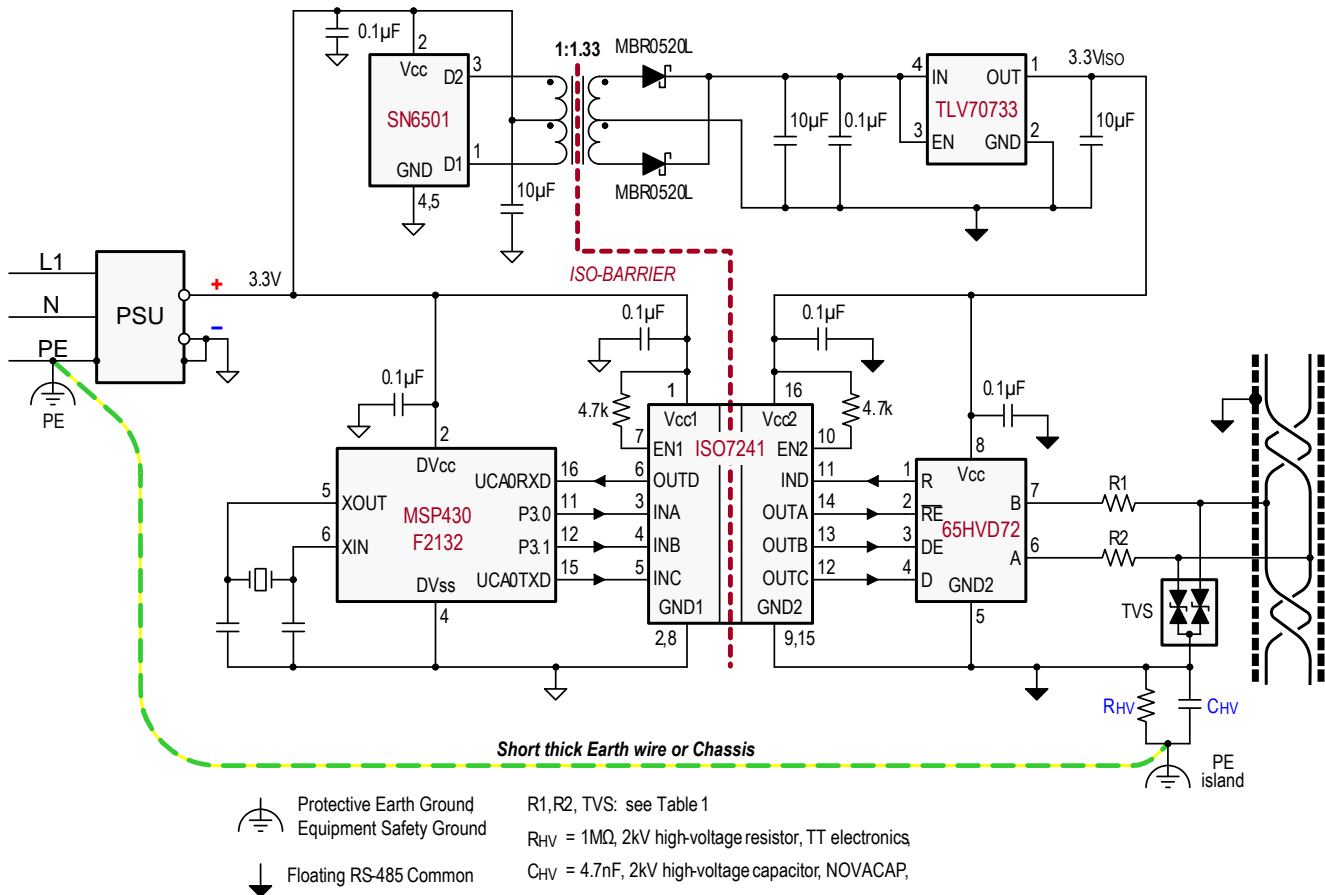

Figure 27. Isolated Bus Node with Transient Protection

Power isolation is accomplished using the push-pull transformer driver SN6501 and a low-cost LDO, TLV70733.

Signal isolation uses the quadruple digital isolator ISO7241. Notice that both enable inputs, EN₁ and EN₂, are pulled up via 4.7 kΩ resistors to limit their input currents during transient events.

While the transient protection is similar to the one in Figure 26 (left circuit), an additional high-voltage capacitor is used to divert transient energy from the floating RS-485 common further towards Protective Earth (PE) ground. This is necessary as noise transients on the bus are usually referred to Earth potential.

R_{HV} refers to a high voltage resistor, and in some applications even a varistor. This resistance is applied to prevent charging of the floating ground to dangerous potentials during normal operation.

Occasionally varistors are used instead of resistors to rapidly discharge C_{HV}, if it is expected that fast transients might charge C_{HV} to high-potentials.

Note that the PE island represents a copper island on the PCB for the provision of a short, thick Earth wire connecting this island to PE ground at the entrance of the power supply unit (PSU).

In equipment designs using a chassis, the PE connection is usually provided through the chassis itself. Typically the PE conductor is tied to the chassis at one end while the high-voltage components, C_{HV} and R_{HV}, are connecting to the chassis at the other end.

10.2.3 Application Curves

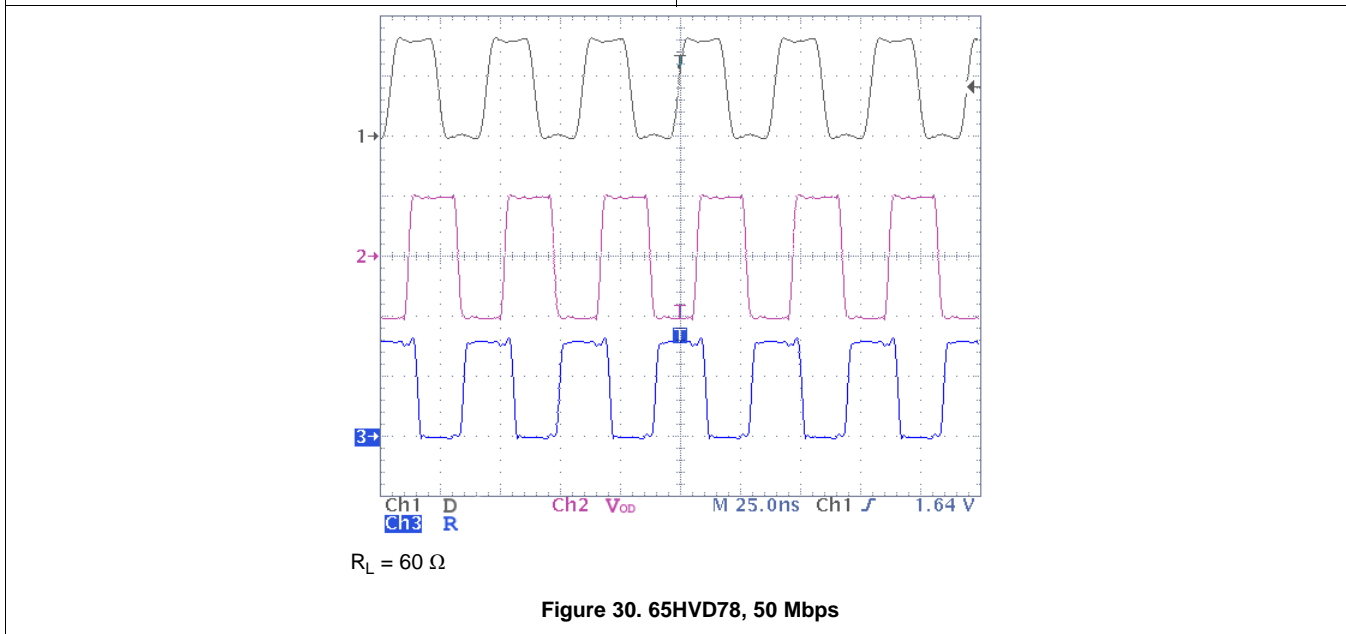
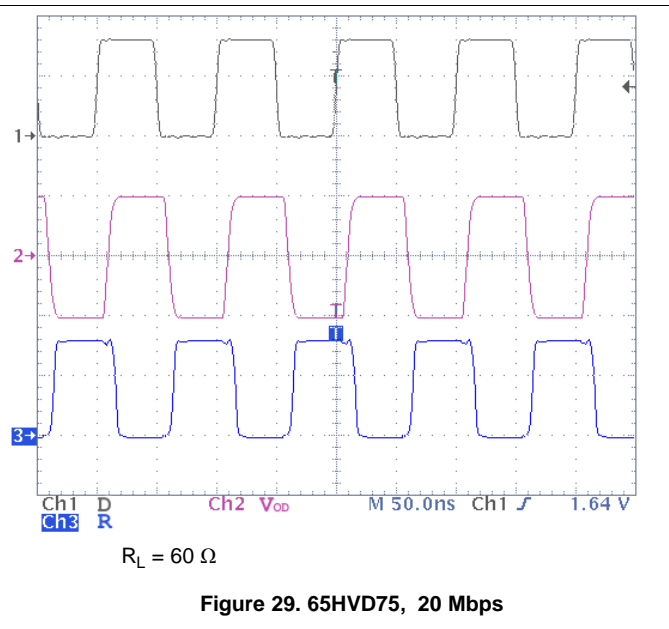
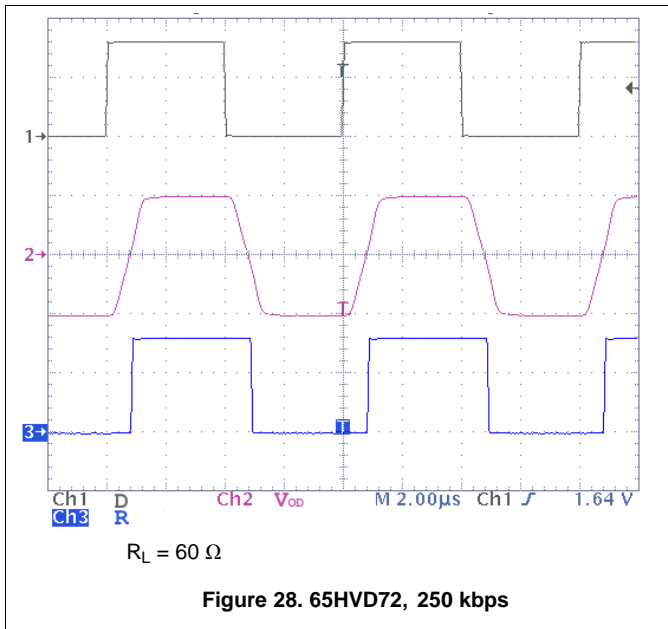

Important statement:

Huaguan Semiconductor Co,Ltd. reserves the right to change the products and services provided without notice. Customers should obtain the latest relevant information before ordering, and verify the timeliness and accuracy of this information.

Customers are responsible for complying with safety standards and taking safety measures when using our products for system design and machine manufacturing to avoid potential risks that may result in personal injury or property damage.

Our products are not licensed for applications in life support, military, aerospace, etc., so we do not bear the consequences of the application of these products in these fields.

Our documentation is only permitted to be copied without any tampering with the content, so we do not accept any responsibility or liability for the altered documents.

X-ON Electronics

Largest Supplier of Electrical and Electronic Components

Click to view similar products for [RS-422/RS-485 Interface IC](#) category:

Click to view products by [HGSEMI](#) manufacturer:

Other Similar products are found below :

[402824F](#) [702835FB](#) [MAX488ECPA](#) [MAX3491CSDT](#) [MAX3490AEGSA+](#) [MAX3483AEASA+](#) [MAX3491EESDT](#) [MAX3488AEGSA+](#)
[MAX3083CSD](#) [MAX487CSA](#) [SP3071EEN-L](#) [SP3072EEN-L/TR](#) [SP3075EEN-L](#) [SP3075EEN-L/TR](#) [SP3077EEN-L](#) [SP3078EEN-L](#)
[SP3078EEN-L/TR](#) [SP3082EEN-L](#) [SP3088EEN-L](#) [SP3483CN-L](#) [SP3483CN-L/TR](#) [SP3483EN-L](#) [SP3485CN-L](#) [SP3485CN-L/TR](#) [SP3485EN-](#)
[L](#) [SP3485EN-L/TR](#) [SP3490EN-L](#) [SP3494EN-L](#) [SP481EEN-L/TR](#) [SP483EN-L/TR](#) [SP490EEN-L/TR](#) [SP491EN-L/TR](#) [XR3078XID-F](#)
[SP3082EEN-L/TR](#) [SP330EEY-L/TR](#) [MAX14783EATA+T](#) [MAX3098EBCEE+T](#) [MAX3045BESE+T](#) [MAX22501EATA+T](#)
[MAX22502EATC+T](#) [MAX3042BCSE+T](#) [SP3077EEN-L/TR](#) [MAX487ESA+TCBX](#) [MAX1483CUA+T](#) [MAX487CUA+T](#) [CA-IS3082W](#) [CA-](#)
[IS3088W](#) [SP3074EEN-L/TR](#) [SP3483EN-L/TR](#) [NSI83085](#)