

Quadruple 2-Input NAND Gates with Open-Drain Outputs

Description

This device contains four independent 2-input NAND Gates with open-drain outputs. Each gate performs the Boolean function $Y = A \bullet B$ in positive logic

Features

- Wide Operating Voltage Range: 2 V to 6 V
- Outputs Can Drive Up To 10 LSTTL Loads
- Low Power Consumption, 20- μ A Maximum ICC
- Typical tpd = 8 ns at 5 V
- ± 4 -mA Output Drive at 5 V
- Low Input Current of 1 μ A

Applications

- NAND OD

Ordering Information

DEVICE	Package Type	MARKING	Packing	Packing Qty
74HC03N	DIP14	74HC03	TUBE	1000pcs/Box
74HC03M/TR	SOP14	74HC03	REEL	2500pcs/Reel
74HC03MT/TR	TSSOP14	74HC03	REEL	2500pcs/Reel

Functional pinout

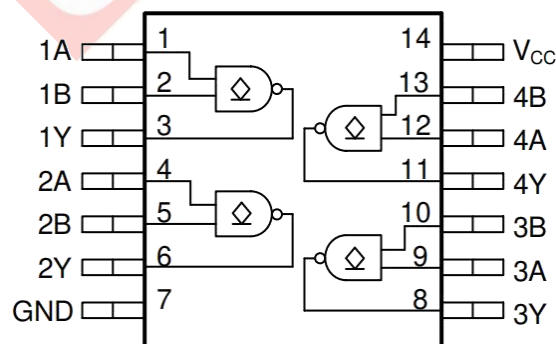

Pin Configuration

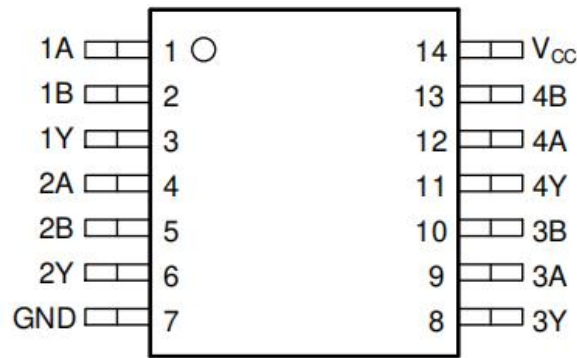

DIP14/SOP14/TSSOP14

Pin Functions

PIN		I/O	DESCRIPTION
NAME	DIP/SOP/TSSOP		
1A	1	Input	Channel 1, Input A
1B	2	Input	Channel 1, Input B
1Y	3	Output	Channel 1, Output Y
2A	4	Input	Channel 2, Input A
2B	5	Input	Channel 2, Input B
2Y	6	Output	Channel 2, Output Y
GND	7	—	Ground
3Y	8	Output	Channel 3, Output Y
3A	9	Input	Channel 3, Input A
3B	10	Input	Channel 3, Input B
4Y	11	Output	Channel 4, Output Y
4A	12	Input	Channel 4, Input A
4B	13	Input	Channel 4, Input B
VCC	14	—	Positive Supply

Absolute Maximum Ratings

over operating free-air temperature range (unless otherwise noted)(1)

		MIN	MAX	UNIT
VCC	Supply voltage	-0.5	7	V
I _{IK}	Input clamp current(2)	V _I < 0 or V _I > VCC		±20 mA
I _{OK}	Output clamp current(2)	V _O < 0 or V _O > VCC		±20 mA
I _O	Continuous output current	V _O = 0 to VCC		±25 mA
	Continuous current through VCC or GND		±50	mA
T _J	Junction temperature(3)		150	°C
T _{stg}	Storage temperature	-65	150	°C

1. Stresses beyond those listed under Absolute Maximum Rating may cause permanent damage to the device. These are stress ratings only, which do not imply functional operation of the device at these or any other conditions beyond those indicated under Recommended Operating Condition. Exposure to absolute-maximum-rated conditions for extended periods may affect device reliability.
2. The input and output voltage ratings may be exceeded if the input and output current ratings are observed.
3. Guaranteed by design.

Recommended Operating Conditions

over operating free-air temperature range (unless otherwise noted)

		MIN	NOM	MAX	UNIT
VCC	Supply voltage	2	5	6	V
V _{IH}	High-level input voltage	VCC = 2 V	1.5		V
		VCC = 4.5 V	3.15		
		VCC = 6 V	4.2		
V _{IL}	Low-level input voltage	VCC = 2 V	0.5		V
		VCC = 4.5 V	1.35		
		VCC = 6 V	1.8		
V _I	Input voltage	0	VCC		V
V _O	Output voltage	0	VCC		V
Δt/Δv	Input transition rise and fall rate	VCC = 2 V	1000		ns
		VCC = 4.5 V	500		
		VCC = 6 V	400		
T _A	Operating free-air temperature	74HC03	-40	85	°C

Thermal Information

THERMAL METRIC(1)		74HC03			UNIT
		(SOP)	(DIP)	(TSSOP)	
		14 PINS	14 PINS	14 PINS	
R θ JA	Junction-to-ambient thermal resistance	133.6	66.0	151.7	°C/W
R θ JC(top)	Junction-to-case (top) thermal resistance	89	53.7	79.4	°C/W
R θ JB	Junction-to-board thermal resistance	89.5	45.7	94.7	°C/W
Ψ JT	Junction-to-top characterization parameter	45.5	33.3	25.2	°C/W
Ψ JB	Junction-to-board characterization parameter	89.1	45.5	94.1	°C/W
R θ JC(bot)	Junction-to-case (bottom) thermal resistance	N/A	N/A	N/A	°C/W

Electrical Characteristics

over operating free-air temperature range (unless otherwise noted)⁽¹⁾⁽²⁾

PARAMETER		TEST CONDITIONS		VCC	Operating free-air temperature (TA)						UNIT
					25°C			-40°C to 85°C			
					MIN	TYP	MAX	MIN	TYP	MAX	
IOH	Output voltage	VI = VIH or VIL	VO = VCC	6 V	0.01	0.5			5	μ A	
VOL	Low-level output voltage	VI = VIH or VIL	IOL = 20 μ A	2 V	0.002	0.1			0.1	V	
				4.5 V	0.001	0.1		0.1			
				6 V	0.001	0.1		0.1			
			IOL = 4 mA	4.5 V	0.17	0.26		0.33			
			IOL = 5.2 mA	6 V	0.15	0.26		0.33			
II	Input leakage current	VI = VCC or 0		6 V		\pm 0.1			\pm 1	μ A	
ICC	Supply current	VI = VCC or 0	IO = 0	6 V		2			20	μ A	
Ci	Input capacitance			2 V to 6 V		3	10		10	pF	

(1) VCCI is the VCC associated with the input port.

(2) VCCO is the VCC associated with the output port.

Switching Characteristics

over operating free-air temperature range (unless otherwise noted)

PARAMETER	FROM	TO	VCC	Operating free-air temperature (TA)						UNIT
				25°C			-40°C to 85°C			
				MIN	TYP	MAX	MIN	TYP	MAX	
t _{plh}	A or B	Y	2 V	60	105	131			ns	
			4.5 V	13	25	31				
			6 V	10	23	27				
t _{phl}	A or B	Y	2 V	50	100	125			ns	
			4.5 V	10	20	25				
			6 V	8	17	21				
t _t		Y	2 V	38	75	95			ns	
			4.5 V	8	15	19				
			6 V	6	13	16				

Operating Characteristics

over operating free-air temperature range; typical values measured at TA = 25°C (unless otherwise noted)

PARAMETER	TEST CONDITIONS	VCC	MIN	TYP	MAX	UNIT
C _{pd}	No load	2 V to 6 V		20		pF

Typical Characteristics (TA = 25°C)

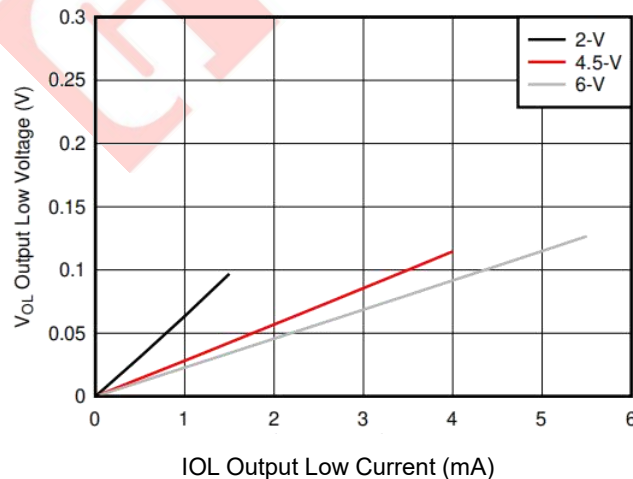
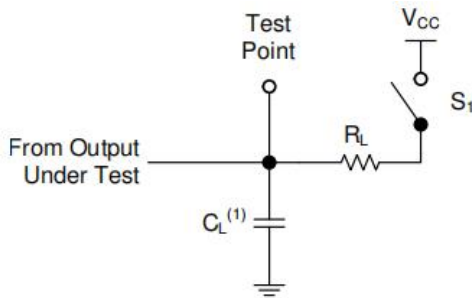

Figure 5-1. Typical output voltage in the low state (VOL)

Parameter Measurement Information

Phase relationships between waveforms were chosen arbitrarily. All input pulses are supplied by generators having the following characteristics: PRR ≤ 1 MHz, ZO = 50 Ω, tt < 6 ns.

The outputs are measured one at a time, with one input transition per measurement



A. CL = 50 pF and includes probe and jig capacitance

Figure 6-1. Load Circuit

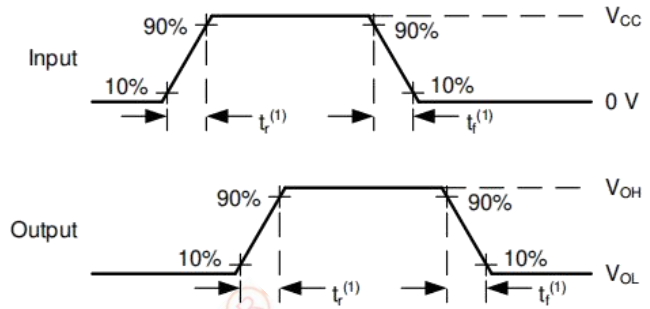

A. tt is the greater of tr and tf.

Figure 6-2. Voltage Wave forms Transition Times

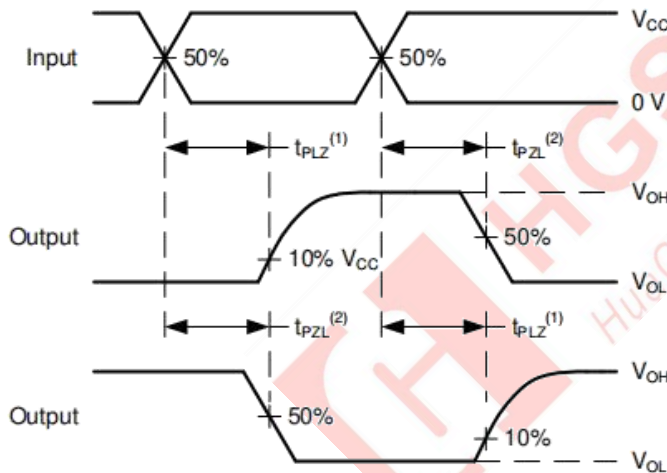

A. The maximum between tPLH and tPHL is used for tpd.

Figure 6-3. Voltage Wave forms Propagation Delays

Detailed Description

Overview

This device contains four independent 2-input NAND gates with open-drain outputs. Each gate performs the Boolean function $Y = A \bullet B$ in positive logic.

Functional Block Diagram

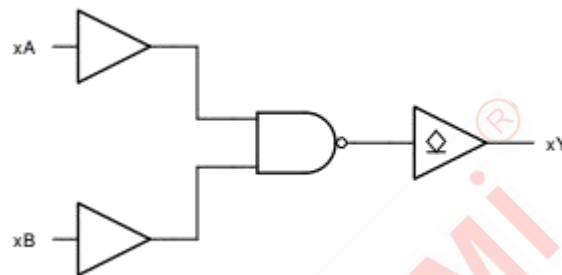

Feature Description

CMOS Open-Drain Outputs

The open-drain output allows the device to sink current to GND but not to source current from VCC. When the output is not actively pulling the line low, it will go into a high impedance state. This allows the device to be used for a wide variety of applications, including up-translation and down-translation, as the output voltage can be determined by an external pull-up resistor.

The current drive capability of this device creates fast edges into light loads, so routing and load conditions should be considered to prevent ringing. Additionally, the outputs of this device are capable of driving larger currents than the device can sustain without being damaged. It is important for the power output of the device to be limited to avoid thermal runaway and damage due to over-current. The electrical and thermal limits defined in the Absolute Maximum Ratings must be followed at all times.

The 74HC03 can drive a load with a total capacitance less than or equal to the maximum load listed in the Switching Characteristics connected to a high-impedance CMOS input while still meeting all of the datasheet specifications. Larger capacitive loads can be applied, however it is not recommended to exceed the provided load value. If larger capacitive loads are required, it is recommended to add a series resistor between the output and the capacitor to limit output current to the values given in the Absolute Maximum Ratings.

Standard CMOS Inputs

Standard CMOS inputs are high impedance and are typically modeled as a resistor from the input to ground in parallel with the input capacitance given in the Electrical Characteristics. The worst case resistance is calculated with the maximum input voltage, given in the Absolute Maximum Ratings, and the maximum input leakage current, given in the Electrical Characteristics, using ohm's law ($R = V \div I$).

Signals applied to the inputs need to have fast edge rates, as defined by the input transition time in the Recommended Operating Conditions to avoid excessive current consumption and oscillations. If a slow or noisy input signal is required, a device with a Schmitt-trigger input should be used to condition the input signal prior to the standard CMOS input.

Clamp Diode Structure

The inputs and outputs to this device have both positive and negative clamping diodes as depicted in Figure 7-1.

CAUTION

Voltages beyond the values specified in the Absolute Maximum Ratings table can cause damage to the device. The recommended input and output voltage ratings may be exceeded if the input and output clamp-current ratings are observed.

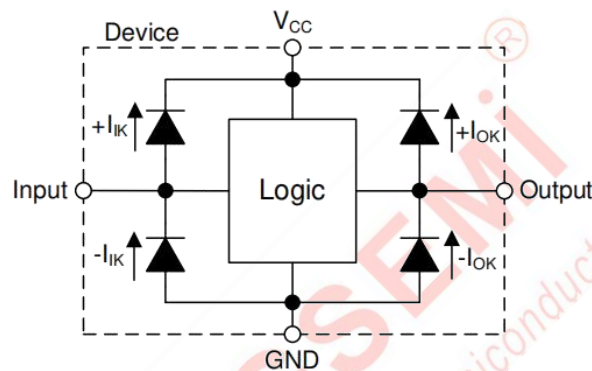

Figure 7-1. Electrical Placement of Clamping Diodes for Each Input and Output

Device Functional Modes

Table 7-1. Function Table

INPUTS		OUTPUT
A	B	Y
H	H	L
L	X	Z
X	L	Z

Physical Dimensions

DIP14

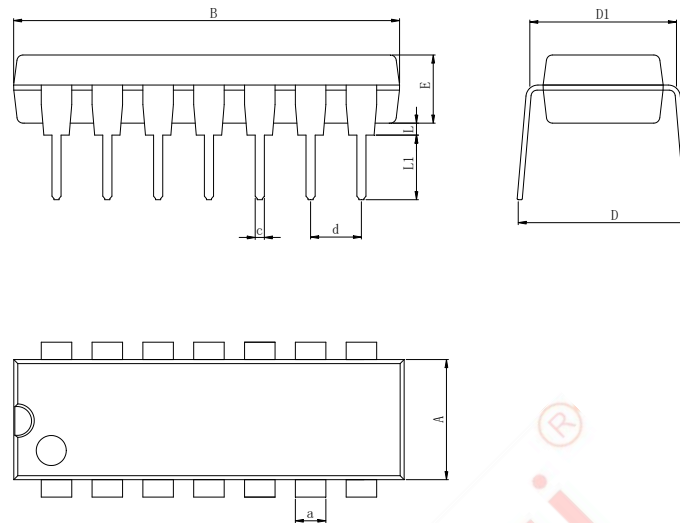

Dimensions In Millimeters(DIP14)

Symbol:	A	B	D	D1	E	L	L1	a	c	d
Min:	6.10	18.94	8.40	7.42	3.10	0.50	3.00	1.50	0.40	2.54 BSC
Max:	6.68	19.56	9.00	7.82	3.55	0.70	3.60	1.55	0.50	

SOP14

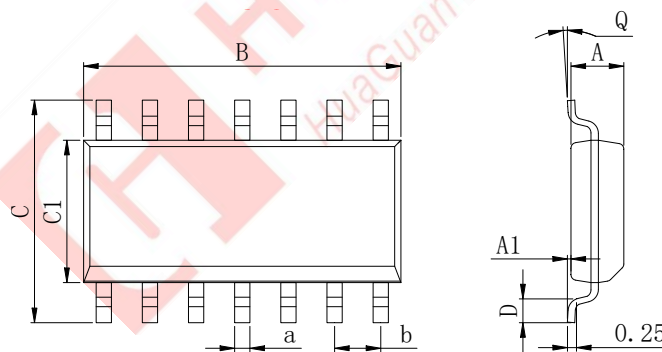

Dimensions In Millimeters(SOP14)

Symbol:	A	A1	B	C	C1	D	Q	a	b
Min:	1.35	0.05	8.55	5.80	3.80	0.40	0°	0.35	1.27 BSC
Max:	1.55	0.20	8.75	6.20	4.00	0.80	8°	0.45	

TSSOP14

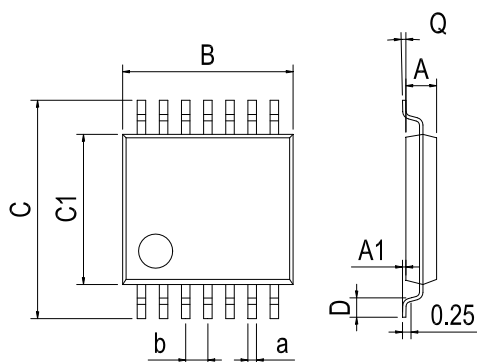

Dimensions In Millimeters(TSSOP14)									
Symbol:	A	A1	B	C	C1	D	Q	a	b
Min:	0.85	0.05	4.90	6.20	4.30	0.40	0°	0.20	0.65 BSC
Max:	0.95	0.20	5.10	6.60	4.50	0.80	8°	0.25	

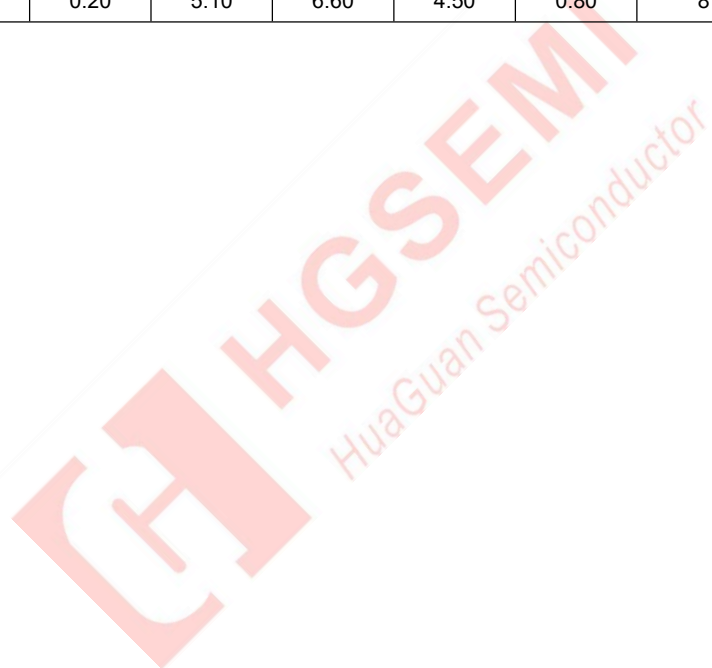

IMPORTANT STATEMENT:

Huaguan Semiconductor Co,Ltd. reserves the right to change the products and services provided without notice. Customers should obtain the latest relevant information before ordering, and verify the timeliness and accuracy of this information.

Customers are responsible for complying with safety standards and taking safety measures when using our products for system design and machine manufacturing to avoid potential risks that may result in personal injury or property damage.

Our products are not licensed for applications in life support, military, aerospace, etc., so we do not bear the onsequences of the application of these products in these fields.

Huaguan Semiconductor Co,Ltd. the performance of the semiconductor products produced by the company can reach the performance indicators that can be applied at the time of sales. The use of testing and other quality control technologies is limited to the quality assurance scope of Huaguan semiconductor. Not all parameters of each device need to be tested. The above documents are for reference only, and all are subject to the physical parameters.

Our documentation is only permitted to be copied without any tampering with the content, so we do not accept any responsibility or liability for the altered documents.

X-ON Electronics

Largest Supplier of Electrical and Electronic Components

Click to view similar products for [Logic Gates](#) category:

Click to view products by [HGSEMI](#) manufacturer:

Other Similar products are found below :

[74HC85N](#) [NL17SG08P5T5G](#) [NL17SG32DFT2G](#) [NLVHC1G08DFT1G](#) [CD4068BE](#) [TC7SET32FU\(T5L,JF\)](#) [NL17SG86DFT2G](#)
[NLV14001UBDR2G](#) [NLX1G11AMUTCG](#) [NLX1G97MUTCG](#) [74LS38](#) [74LVC1G08Z-7](#) [74LVC32ADTR2G](#) [CD4025BE](#)
[MC74HCT20ADTR2G](#) [NLV17SZ00DFT2G](#) [NLV17SZ02DFT2G](#) [NLV17SZ126DFT2G](#) [NLV27WZ17DFT2G](#) [NLV74HC02ADR2G](#)
[74HC32S14-13](#) [74LS133](#) [74LVC1G32Z-7](#) [74LVC1G86Z-7](#) [NLV74HC14ADR2G](#) [NLV74HC20ADR2G](#) [NLX2G86MUTCG](#)
[NLU1G00AMUTCG](#) [74LVC2G32RA3-7](#) [74LVC2G00HD4-7](#) [NL17SG02P5T5G](#) [74LVC2G86HK3-7](#) [NL17SG08DFT2G](#)
[NLVVHC1G14DFT2G](#) [NLX1G99DMUTWG](#) [NLVX1G11AMUTCG](#) [NLVVHC1G00DFT2G](#) [NLV7SZ57DFT2G](#) [NLV74VHC04DTR2G](#)
[NLV27WZ86USG](#) [NLV27WZ00USG](#) [NLU1G86CMUTCG](#) [NLU1G08CMUTCG](#) [NL17SZ32P5T5G](#) [NL17SZ00P5T5G](#) [NL17SH02P5T5G](#)
[74AUP2G00RA3-7](#) [NLVVHC1GT00DFT2G](#) [NLV74HC02ADTR2G](#) [NLX1G332CMUTCG](#)