

74HC07 HEX BUFFER (OPEN DRAIN)

- **HIGH SPEED:**
 $t_{PD} = 6\text{ns}$ (TYP.) at $V_{CC} = 6\text{V}$
- **LOW POWER DISSIPATION:**
 $I_{CC} = 1\mu\text{A}$ (MAX.) at $T_A=25^\circ\text{C}$
- **HIGH NOISE IMMUNITY:**
 $V_{NIH} = V_{NIL} = 28\% V_{CC}$ (MIN.)
- **WIDE OPERATING VOLTAGE RANGE:**
 V_{CC} (OPR) = 2V to 6V
- **PIN AND FUNCTION COMPATIBLE WITH 74 SERIES 07**

DESCRIPTION

The 74HC07 is an high speed CMOS HEX OPEN DRAIN BUFFER fabricated with silicon gate C²MOS technology.

The internal circuit is composed of 2 stages including buffer output, which enables high noise immunity and stable output.

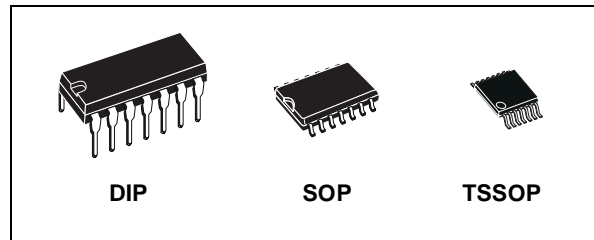

ORDER CODES

PACKAGE	TUBE	T & R
DIP	74HC07B	
SOP	74HC07M	74HC07RM13TR

All inputs are equipped with protection circuits against static discharge and transient excess voltage.

PIN CONNECTION AND IEC LOGIC SYMBOLS

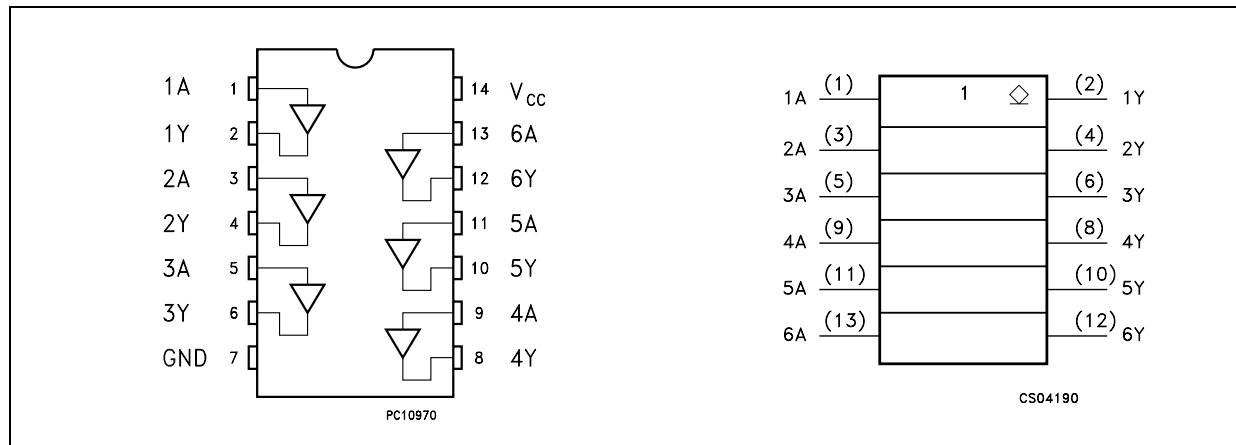

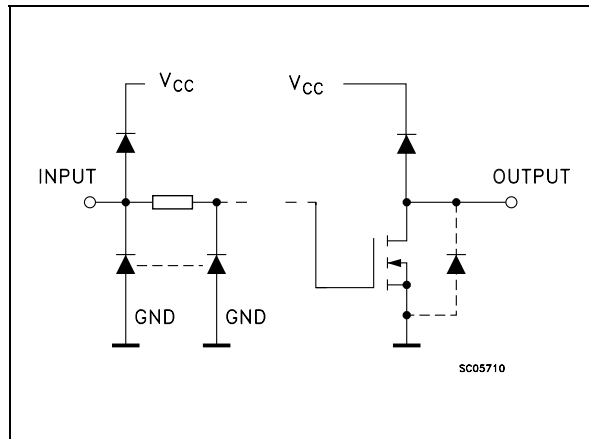
INPUT AND OUTPUT EQUIVALENT CIRCUIT

PIN DESCRIPTION

PIN No	SYMBOL	NAME AND FUNCTION
1, 3, 5, 9, 11, 13	1A to 6A	Data Inputs
2, 4, 6, 8, 10, 12	1Y to 6Y	Data Outputs
7	GND	Ground (0V)
14	V _{CC}	Positive Supply Voltage

TRUTH TABLE

A	Y
L	L
H	Z

Z : High Impedance

ABSOLUTE MAXIMUM RATINGS

Symbol	Parameter	Value	Unit
V _{CC}	Supply Voltage	-0.5 to +7	V
V _I	DC Input Voltage	-0.5 to V _{CC} + 0.5	V
V _O	DC Output Voltage	-0.5 to V _{CC} + 0.5	V
I _{IK}	DC Input Diode Current	± 20	mA
I _{OK}	DC Output Diode Current	± 20	mA
I _O	DC Output Current	± 25	mA
I _{CC} or I _{GND}	DC V _{CC} or Ground Current	± 50	mA
P _D	Power Dissipation	500(*)	mW
T _{stg}	Storage Temperature	-65 to +150	°C
T _L	Lead Temperature (10 sec)	300	°C

Absolute Maximum Ratings are those values beyond which damage to the device may occur. Functional operation under these conditions is not implied

(*) 500mW at 65 °C; derate to 300mW by 10mW/°C from 65°C to 85°C

RECOMMENDED OPERATING CONDITIONS

Symbol	Parameter	Value	Unit	
V _{CC}	Supply Voltage	2 to 6	V	
V _I	Input Voltage	0 to V _{CC}	V	
V _O	Output Voltage	0 to V _{CC}	V	
T _{op}	Operating Temperature	-55 to 125	°C	
t _r , t _f	Input Rise and Fall Time	V _{CC} = 2.0V	0 to 1000	ns
		V _{CC} = 4.5V	0 to 500	ns
		V _{CC} = 6.0V	0 to 400	ns

DC SPECIFICATIONS

Symbol	Parameter	Test Condition		Value						Unit	
		V _{CC} (V)		T _A = 25°C			-40 to 85°C		-55 to 125°C		
				Min.	Typ.	Max.	Min.	Max.	Min.		Max.
V _{IH}	High Level Input Voltage	2.0		1.5			1.5		1.5		V
		4.5		3.15			3.15		3.15		
		6.0		4.2			4.2		4.2		
V _{IL}	Low Level Input Voltage	2.0				0.5		0.5		0.5	V
		4.5				1.35		1.35		1.35	
		6.0				1.8		1.8		1.8	
V _{OL}	Low Level Output Voltage	2.0	I _O =20 μA		0.0	0.1		0.1		0.1	V
		4.5	I _O =20 μA		0.0	0.1		0.1		0.1	
		6.0	I _O =20 μA		0.0	0.1		0.1		0.1	
		4.5	I _O =4.0 mA		0.17	0.26		0.33		0.40	
		6.0	I _O =5.2 mA		0.18	0.26		0.33		0.40	
I _I	Input Leakage Current	6.0	V _I = V _{CC} or GND			± 0.1		± 1		± 1	μA
I _{OZ}	Output Leakage Current	6.0	V _I = V _{IH} or V _{IL} V _O = V _{CC} or GND			± 0.5		± 5		± 10	μA
I _{CC}	Quiescent Supply Current	6.0	V _I = V _{CC} or GND			1		10		20	μA

AC ELECTRICAL CHARACTERISTICS (C_L = 50 pF, Input t_r = t_f = 6ns)

Symbol	Parameter	Test Condition		Value						Unit	
		V _{CC} (V)		T _A = 25°C			-40 to 85°C		-55 to 125°C		
				Min.	Typ.	Max.	Min.	Max.	Min.		Max.
t _{THL}	Output Transition Time	2.0			30	75		95		110	ns
		4.5			8	15		19		22	
		6.0			7	13		16		19	
t _{PLZ}	Propagation Delay Time	2.0	R _L = 1 KΩ		10	90		115		135	ns
		4.5			7	18		23		27	
		6.0			6	15		20		23	
t _{PZL}	Propagation Delay Time	2.0	R _L = 1 KΩ		17	90		115		135	ns
		4.5			7	18		23		27	
		6.0			5	15		20		23	

CAPACITIVE CHARACTERISTICS

Symbol	Parameter	Test Condition		Value						Unit	
		V _{CC} (V)		T _A = 25°C			-40 to 85°C		-55 to 125°C		
				Min.	Typ.	Max.	Min.	Max.	Min.		Max.
C _{IN}	Input Capacitance	5.0			5	10		10		10	pF
C _{OUT}	Output Capacitance	5.0			3						pF
C _{PD}	Power Dissipation Capacitance (note 1)	5.0			4						pF

1) C_{PD} is defined as the value of the IC's internal equivalent capacitance which is calculated from the operating current consumption without load. (Refer to Test Circuit). Average operating current can be obtained by the following equation. $I_{CC(opr)} = C_{PD} \times V_{CC} \times f_{IN} + I_{CC}/6$ (per gate)

TEST CIRCUIT

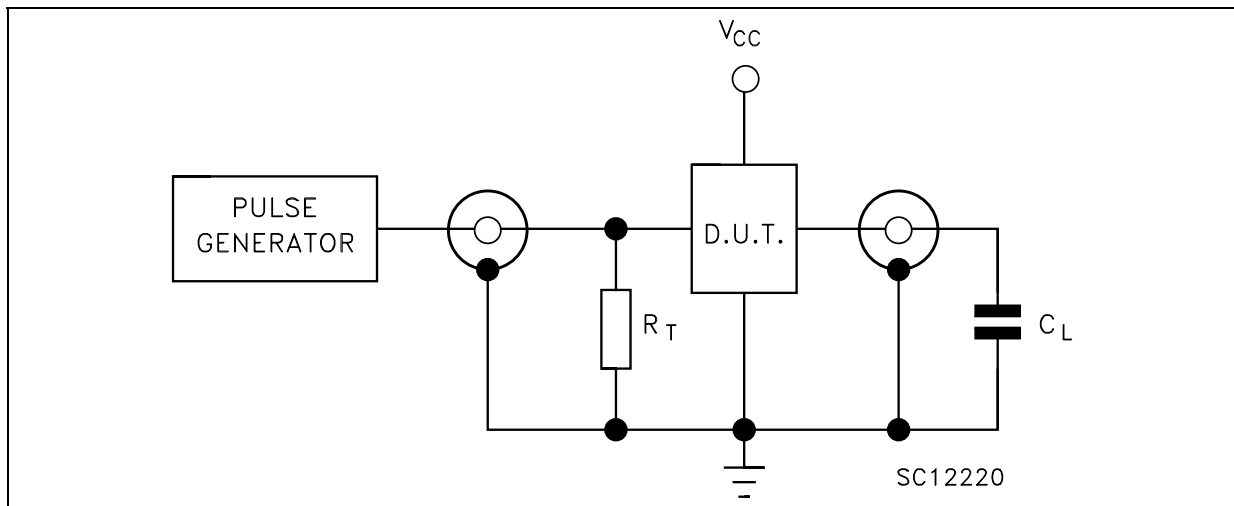

C_L = 50pF or equivalent (includes jig and probe capacitance)
R_T = Z_{OUT} of pulse generator (typically 50Ω)

WAVEFORM : PROPAGATION DELAY TIME (f=1MHz; 50% duty cycle)

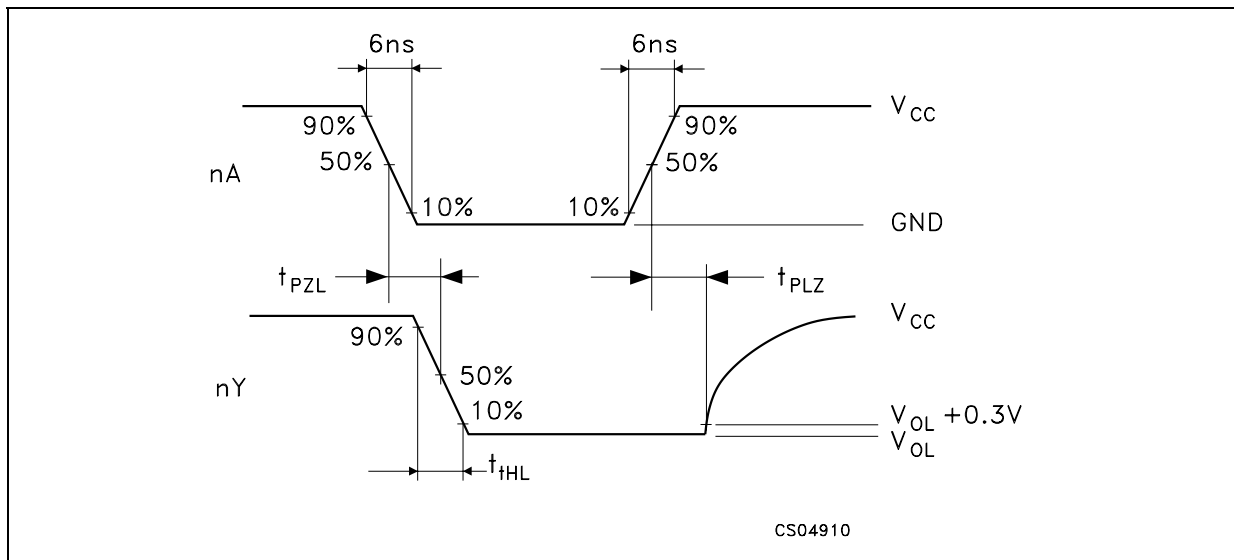

X-ON Electronics

Largest Supplier of Electrical and Electronic Components

Click to view similar products for [hgsemi](#) manufacturer:

Other Similar products are found below :

[PCF8574AP](#) [MP1484M/TR](#) [LM2576HVS-15/TR](#) [TLC2543N](#) [74HC245N](#) [UC3844M/TR](#) [NE556N](#) [LM339N](#) [OP27AM/TR](#) [LM385M3-1.2/TR](#) [LM2575S-3.3/TR](#) [LM2596S-ADJ/TR](#) [HG82C55AN](#) [74C922WM](#) [LM2596T-3.3](#) [LM7805CS/TR](#) [MAX3085EIM/TR](#) [AT24C128N](#) [CD4040BM/TR](#) [LM2591HVS-12](#) [UC3843M/TR](#) [L298N](#) [TLC2543IM](#) [74C923WN](#) [LMV722M/TR](#) [HG82C53N](#) [PCF8574AT](#) [HG82C51N](#) [TLC1543CN](#) [TLC2543CM](#) [LM2591HVS-5.0](#) [MIC39302S/TR](#) [MC34063N](#) [MIC39301S-3.3/TR](#) [AT24C256N](#) [LM258N](#) [TLC1543WM](#) [AP1501-5.0/TR](#) [MA7219N](#) [HG1501S-5.0/TR](#) [74HC4053M/TR](#) [HG25Q40M/TR](#) [LM2575T-5.0](#) [HG2277M/TR](#) [HG1501S-ADJ/TR](#) [TEA2025N](#) [LM2595S-3.3/TR](#) [PCF8574P](#) [MC1413N](#) [LM2596T-12](#)