

Octal D-type flip-flop; positive edge-trigger; 3-state

General Description

The 74HC/HCT374 is an octal positive-edge triggered D-type flip-flop with 3-state outputs. The device features a clock (CP) and output enable (\overline{OE}) inputs. The flip-flops will store the state of their individual D-inputs that meet the set-up and hold time requirements on the LOW-to-HIGH clock (CP) transition. A HIGH on \overline{OE} causes the outputs to assume a high-impedance OFF-state. Operation of the \overline{OE} input does not affect the state of the flip-flops. Inputs also include clamp diodes, this enables the use of current limiting resistors to interface inputs to voltages in excess of VCC.

The 74HCT374 features reduced input threshold levels to allow interfacing to TTL logic levels.

Features:

- Input levels:
For 74HC374: CMOS level
For 74HCT374: TTL level
- Octal bus interface
- Non-inverting 3-state outputs
- 8-bit positive, edge-triggered register
- Common 3-state output enable input
- Independent register and 3-state buffer operation
- Specified from -40°C to +85°C
- Packaging information:
DIP20/SOP20/TSSOP20

ORDERING INFORMATION

DEVICE	Package Type	MARKING	Packing	Packing Qty
74HC374N	DIP20	74HC374	TUBE	720pcs/box
74HCT374N	DIP20	74HCT374	TUBE	720pcs/box
74HC374M/TR	SOP20	74HC374	REEL	2000pcs/reel
74HCT374M/TR	SOP20	74HCT374	REEL	2000pcs/reel
74HC374MT/TR	TSSOP20	HC374	REEL	2500pcs/reel
74HCT374MT/TR	TSSOP20	HCT374	REEL	2500pcs/reel

Block Diagram

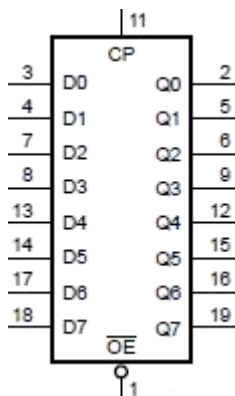

Figure 1. Logic symbol

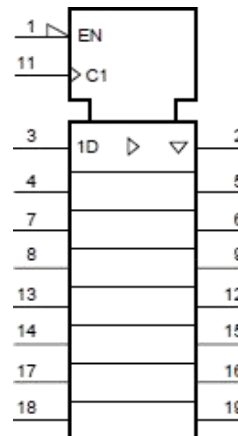

Figure 2. IEC logic symbol

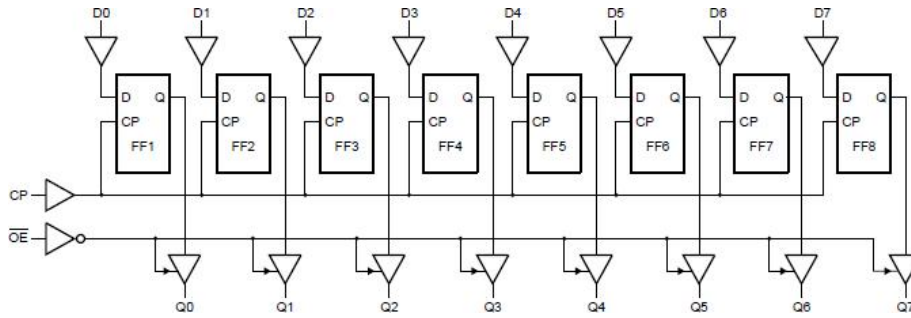

Figure 3. Logic diagram

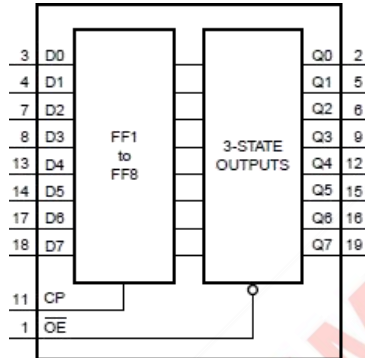

Figure 4. Functional diagram

Pin Configurations



Pin Description

Pin No.	Pin Name	Description	Pin No.	Pin Name	Description
1	\overline{OE}	output enable input (active LOW)	11	CP	clock input (LOW-to-HIGH, edge-triggered)
2	Q0	data output	12	Q4	data output
3	D0	data input	13	D4	data input
4	D1	data input	14	D5	data input
5	Q1	data output	15	Q5	data output
6	Q2	data output	16	Q6	data output
7	D2	data input	17	D6	data input
8	D3	data input	18	D7	data input
9	Q3	data output	19	Q7	data output
10	GND	ground (0V)	20	VCC	supply voltage

Function Table

Operating modes	Input			Internal flip-flops	Output
	\overline{OE}	CP	Dn		Qn
Load and read register	L	↑	l	L	L
	L	↑	h	H	H
Load register and disable outputs	H	↑	l	L	Z
	H	↑	h	H	Z

Note: H=HIGH voltage level; L=LOW voltage level; X=don't care; Z=high-impedance OFF-state;

h=HIGH voltage level one set-up time prior to the LOW-to-HIGH clock transition;

l=LOW voltage level one set-up time prior to the LOW-to-HIGH clock transition;

↑=LOW-to-HIGH clock transition.

Absolute Maximum Ratings

(Voltages are referenced to GND(ground=0V), unless otherwise specified.)

Parameter	Symbol	Conditions	Min.	Max.	Unit
supply voltage	VCC	-	-0.5	+7.0	V
input clamping current	I _{IK}	$V_I < -0.5V$ or $V_I > V_{CC}+0.5V$	-	±20	mA
output clamping current	I _{OK}	$V_O < -0.5V$ or $V_O > V_{CC}+0.5V$	-	±20	mA
output current	I _o	$-0.5V < V_O < V_{CC}+0.5V$	-	±35	mA
supply current	I _{CC}	-	-	70	mA
ground current	I _{GND}	-	-70	-	mA
storage temperature	T _{stg}	-	-65	+150	°C
total power dissipation	P _{tot}	-	-	500	mW
Soldering temperature	T _L	10s	DIP	245	°C
			SOP	250	

Note:

For DIP20 packages: above 70°C the value of P_{tot} derates linearly with 12mW/K.

For SOP20 packages: above 70°C the value of P_{tot} derates linearly with 8mW/K.

For TSSOP20 packages: above 60°C the value of P_{tot} derates linearly with 5.5mW/K.

Recommended Operating Conditions

74HC374

Parameter	Symbol	Conditions	Min.	Typ.	Max.	Unit
supply voltage	VCC	-	2.0	5.0	6.0	V
input voltage	V _I	-	0	-	VCC	V
output voltage	V _O	-	0	-	VCC	V
Input transition rise and fall rate	$\Delta t/\Delta V$	V _{CC} =2.0V	-	-	625	ns/V
		V _{CC} =4.5V	-	1.67	139	ns/V
		V _{CC} =6.0V	-	-	83	ns/V
ambient temperature	T _{amb}	-	-40	-	+85	°C

74HCT374

Parameter	Symbol	Conditions	Min.	Typ.	Max.	Unit
supply voltage	V _{CC}	-	4.5	5.0	5.5	V
input voltage	V _I	-	0	-	V _{CC}	V
output voltage	V _O	-	0	-	V _{CC}	V
input transitionrise and fall rate	$\Delta t/\Delta V$	V _{CC} =2.0V	-	-	-	ns/V
		V _{CC} =4.5V	-	1.67	139	ns/V
		V _{CC} =6.0V	-	-	-	ns/V
ambient temperature	T _{amb}	-	-40	-	+85	°C

Electrical Characteristics
DC Characteristics 1

 (T_{amb}=25°C, voltages are referenced to GND (ground=0V), unless otherwise specified.)

Parameter	Symbol	Conditions	Min.	Typ.	Max.	Unit	
74HC374							
HIGH-level input voltage	V _{IH}	V _{CC} =2.0V	1.5	1.2	-	V	
		V _{CC} =4.5V	3.15	2.4	-	V	
		V _{CC} =6.0V	4.2	3.2	-	V	
LOW-level input voltage	V _{IL}	V _{CC} =2.0V	-	0.8	0.5	V	
		V _{CC} =4.5V	-	2.1	1.35	V	
		V _{CC} =6.0V	-	2.8	1.8	V	
HIGH-level output voltage	V _{OH}	V _I = V _{IH} or V _{IL}	I _O =-20uA; V _{CC} =2.0V	1.9	2.0	-	V
			I _O =-20uA; V _{CC} =4.5V	4.4	4.5	-	V
			I _O =-20uA; V _{CC} =6.0V	5.9	6.0	-	V
			I _O =-6.0mA; V _{CC} =4.5V	3.98	4.32	-	V
			I _O =-7.8mA; V _{CC} =6.0V	5.48	5.81	-	V
LOW-level output voltage	V _{OL}	V _I = V _{IH} or V _{IL}	I _O =20uA; V _{CC} =2.0V	-	0	0.1	V
			I _O =20uA; V _{CC} =4.5V	-	0	0.1	V
			I _O =20uA; V _{CC} =6.0V	-	0	0.1	V
			I _O =6.0mA; V _{CC} =4.5V	-	0.15	0.26	V
			I _O =7.8mA; V _{CC} =6.0V	-	0.16	0.26	V
input leakage current	I _I	V _I =V _{CC} or GND; V _{CC} =6.0V	-	-	±0.1	uA	
OFF-state output current	I _{OZ}	V _I =V _{IH} or V _{IL} ; V _{CC} =6.0V; V _O =V _{CC} or GND	-	-	±0.5	uA	
supply current	I _{CC}	V _I =V _{CC} or GND; I _O =0A; V _{CC} =6.0V	-	-	8.0	uA	
input capacitance	C _i	-	-	3.5	-	pF	
74HCT374							
HIGH-level input voltage	V _{IH}	V _{CC} =4.5V to 5.5V	2.0	1.6	-	V	
LOW-level input voltage	V _{IL}	V _{CC} =4.5V to 5.5V	-	1.2	0.8	V	
HIGH-level output voltage	V _{OH}	V _I = V _{IH} or V _{IL} ; V _{CC} =4.5V	I _O =-20uA	4.4	4.5	-	V
			I _O =-6.0mA	3.98	4.32	-	V
LOW-level	V _{OL}	V _I = V _{IH} or V _{IL} ;	I _O =20uA	-	0	0.1	V

output voltage		$V_{CC}=4.5V$	$I_o=6.0mA$	-	0.16	0.26	V
input leakage current	I_i	$V_i=V_{CC}$ or GND; $V_{CC}=5.5V$		-	-	± 0.1	μA
OFF-state output current	I_{OZ}	$V_i=V_{IH}$ or V_{iL} ; $V_{CC}=5.5V$; $V_o=V_{CC}$ or GND		-	-	± 0.5	μA
supply current	I_{CC}	$V_i=V_{CC}$ or GND; $I_o=0A$; $V_{CC}=5.5V$		-	-	8.0	μA
additional supply current	ΔI_{CC}	per input pin; $V_i=V_{CC}-2.1V$; other inputs at V_{CC} or GND; $I_o=0A$; $V_{CC}=4.5V$ to $5.5V$	\overline{OE} input	-	125	450	μA
			CP input	-	90	324	μA
			Dn input	-	35	126	μA
input capacitance	C_i	-		-	3.5	-	pF

DC Characteristics 2

($T_{amb}=-40^{\circ}C$ to $+85^{\circ}C$, voltages are referenced to GND (ground=0V), unless otherwise specified.)

Parameter	Symbol	Conditions	Min.	Typ.	Max.	Unit	
74HC374							
HIGH-level input voltage	V_{IH}	$V_{CC}=2.0V$	1.5	-	-	V	
		$V_{CC}=4.5V$	3.15	-	-	V	
		$V_{CC}=6.0V$	4.2	-	-	V	
LOW-level input voltage	V_{iL}	$V_{CC}=2.0V$	-	-	0.5	V	
		$V_{CC}=4.5V$	-	-	1.35	V	
		$V_{CC}=6.0V$	-	-	1.8	V	
HIGH-level output voltage	V_{OH}	$V_i = V_{IH}$ or V_{iL}	$I_o=-20\mu A$; $V_{CC}=2.0V$	1.9	-	-	V
			$I_o=-20\mu A$; $V_{CC}=4.5V$	4.4	-	-	V
			$I_o=-20\mu A$; $V_{CC}=6.0V$	5.9	-	-	V
			$I_o=-6.0mA$; $V_{CC}=4.5V$	3.84	-	-	V
			$I_o=-7.8mA$; $V_{CC}=6.0V$	5.34	-	-	V
LOW-level output voltage	V_{OL}	$V_i = V_{IH}$ or V_{iL}	$I_o=20\mu A$; $V_{CC}=2.0V$	-	-	0.1	V
			$I_o=20\mu A$; $V_{CC}=4.5V$	-	-	0.1	V
			$I_o=20\mu A$; $V_{CC}=6.0V$	-	-	0.1	V
			$I_o=6.0mA$; $V_{CC}=4.5V$	-	-	0.33	V
			$I_o=7.8mA$; $V_{CC}=6.0V$	-	-	0.33	V
input leakage current	I_i	$V_i=V_{CC}$ or GND; $V_{CC}=6.0V$	-	-	± 1.0	μA	
OFF-state output current	I_{OZ}	$V_i=V_{IH}$ or V_{iL} ; $V_{CC}=6.0V$; $V_o=V_{CC}$ or GND	-	-	± 5.0	μA	
supply current	I_{CC}	$V_i=V_{CC}$ or GND; $I_o=0A$; $V_{CC}=6.0V$	-	-	80	μA	
input capacitance	C_i	-	-	-	-	pF	
74HCT374							
HIGH-level input voltage	V_{IH}	$V_{CC}=4.5V$ to $5.5V$	2.0	-	-	V	
LOW-level input voltage	V_{iL}	$V_{CC}=4.5V$ to $5.5V$	-	-	0.8	V	
input voltage							
HIGH-level output voltage	V_{OH}	$V_i = V_{IH}$ or V_{iL} ; $V_{CC}=4.5V$	$I_o=-20\mu A$	4.4	-	-	V
			$I_o=-6.0mA$	3.84	-	-	V

LOW-level output voltage	VOL	VI = VIH or VIL; VCC=4.5V	Io=20uA	-	-	0.1	V
			Io=6.0mA	-	-	0.33	V
input leakage current	Ii	VI=VCC or GND; VCC=5.5V		-	-	±1.0	uA
OFF-state output current	IOZ	VI=VIH or VIL; VCC=5.5V; VO=VCC or GND		-	-	±5.0	uA
supply current	ICC	VI=VCC or GND; Io=0A; VCC=5.5V		-	-	80	uA
additional supply current	ΔICC	per input pin; VI=VCC-2.1V; other inputs at VCC or GND; Io=0A; VCC=4.5V to 5.5V;	OE input	-	-	563	uA
			CP input	-	-	405	uA
			Dn input	-	-	158	uA
input capacitance	CI			-	-	-	pF

AC Characteristics 1

(Tamb=25°C, voltages are referenced to GND (ground=0V), unless otherwise specified.)

Parameter	Symbol	Conditions	Min.	Typ.	Max.	Unit	
74HC374							
CP to Qn propagation delay	tpd	see Figure 6	VCC=2.0V	-	50	165	ns
			VCC=4.5V	-	18	33	ns
			VCC=5.0V; CL=15pF	-	15	-	ns
			VCC=6.0V	-	14	18	ns
OE to Qn enable time	ten	see Figure 7	VCC=2.0V	-	41	150	ns
			VCC=4.5V	-	15	30	ns
			VCC=6.0V	-	12	26	ns
OE to Qn disable time	tdis	see Figure 7	VCC=2.0V	-	50	150	ns
			VCC=4.5V	-	18	30	ns
			VCC=6.0V	-	14	26	ns
transition time	tt	Qn output; see Figure 6	VCC=2.0V	-	14	60	ns
			VCC=4.5V	-	5	12	ns
			VCC=6.0V	-	4	10	ns
pulse width	tw	CP; HIGH or LOW; see Figure 6	VCC=2.0V	80	19	-	ns
			VCC=4.5V	16	7	-	ns
			VCC=6.0V	14	6	-	ns
Dn to CP set-up time	tsu	see Figure 6	VCC=2.0V	60	14	-	ns
			VCC=4.5V	12	5	-	ns
			VCC=6.0V	10	4	-	ns
Dn to CPhold time	th	see Figure 6	VCC=2.0V	5	-6	-	ns
			VCC=4.5V	5	-2	-	ns
			VCC=6.0V	5	-2	-	ns
maximum frequency	fmax	CP input; see Figure 6	VCC=2.0V	6.0	23	-	MHz
			VCC=4.5V	30	70	-	MHz
			VCC=5.0V; CL=15pF	-	77	-	MHz
			VCC=6.0V	35	83	-	MHz
power dissipation capacitance	CPD	per flip-flop; VI=GND to VCC		-	17	-	pF
74HCT374							
CP to Qn propagation delay	tpd	see Figure 6	VCC=4.5V	-	16	32	ns
			VCC=5.0V; CL=15pF	-	13	-	ns
OE to Qn enable time	ten	VCC=4.5V; see Figure 7		-	16	30	ns
OE to Qn disable time	tdis	VCC=4.5V; see Figure 7		-	18	28	ns

transition time	t_t	Qn; $V_{CC}=4.5V$; see Figure 6	-	5	12	ns	
pulse width	t_w	CP; HIGH or LOW; $V_{CC}=4.5V$; see Figure 6	19	11	-	ns	
Dn to CP set-up time	t_{su}	$V_{CC}=4.5V$; see Figure 6	12	7	-	ns	
Dn to CPhold time	t_h	$V_{CC}=4.5V$; see Figure 6	5	-3	-	ns	
maximum frequency	f_{max}	CP input; see Figure 6	$V_{CC}=4.5V$	26	44	-	MHz
			$V_{CC}=5.0V$; $C_L=15pF$	-	48	-	MHz
power dissipation capacitance	CPD	per flip-flop; $V_I=GND$ to $V_{CC}-1.5V$	-	17	-	pF	

Note:

- t_{pd} is the same as t_{PLH} and t_{PHL} .
- t_{en} is the same as t_{PZL} and t_{PZH} .
- t_{dis} is the same as t_{PLZ} and t_{PHZ} .
- t_t is the same as t_{THL} and t_{TLH} .
- CPD is used to determine the dynamic power dissipation (P_D in uW).
 $P_D = C_{PD} \times V \times 2 \times f_i \times N + \sum (C_L \times V_{CC}^2 \times f_o)$ where:
 f_i =input frequency in MHz; V_{CC} =supply voltage in V;
 f_o =output frequency in MHz; N=number of inputs switching;
 C_L =output load capacitance in pF; $\sum (C_L \times V_{CC}^2 \times f_o)$ =sum of outputs.

AC Characteristics 2

($T_{amb} = -40^\circ C$ to $+85^\circ C$, voltages are referenced to GND (ground=0V), unless otherwise specified.)

Parameter	Symbol	Conditions	Min.	Typ.	Max.	Unit	
74HC374							
CP to Qn propagation delay	t_{pd}	see Figure 6	$V_{CC}=2.0V$	-	-	205	ns
			$V_{CC}=4.5V$	-	-	41	ns
			$V_{CC}=5.0V$; $C_L=15pF$	-	-	-	ns
			$V_{CC}=6.0V$	-	-	35	ns
\overline{OE} to Qn enable time	t_{en}	see Figure 7	$V_{CC}=2.0V$	-	-	190	ns
			$V_{CC}=4.5V$	-	-	38	ns
			$V_{CC}=6.0V$	-	-	33	ns
\overline{OE} to Qn disable time	t_{dis}	see Figure 7	$V_{CC}=2.0V$	-	-	190	ns
			$V_{CC}=4.5V$	-	-	38	ns
			$V_{CC}=6.0V$	-	-	33	ns
transition time	t_t	Qn output; see Figure 6	$V_{CC}=2.0V$	-	-	75	ns
			$V_{CC}=4.5V$	-	-	15	ns
			$V_{CC}=6.0V$	-	-	13	ns
pulse width	t_w	CP; HIGH or LOW; see Figure 6	$V_{CC}=2.0V$	100	-	-	ns
			$V_{CC}=4.5V$	20	-	-	ns
			$V_{CC}=6.0V$	17	-	-	ns
Dn to CP set-up time	t_{su}	see Figure 6	$V_{CC}=2.0V$	75	-	-	ns
			$V_{CC}=4.5V$	15	-	-	ns
			$V_{CC}=6.0V$	13	-	-	ns
Dn to CPhold time	t_h	see Figure 6	$V_{CC}=2.0V$	5	-	-	ns
			$V_{CC}=4.5V$	5	-	-	ns
			$V_{CC}=6.0V$	5	-	-	ns
maximum frequency	f_{max}	CP input; see Figure 6	$V_{CC}=2.0V$	4.8	-	-	MHz
			$V_{CC}=4.5V$	24	-	-	MHz
			$V_{CC}=5.0V$; $C_L=15pF$	-	-	-	MHz
			$V_{CC}=6.0V$	28	-	-	MHz
power dissipation capacitance	CPD	per flip-flop; $V_I=GND$ to V_{CC}	-	-	-	pF	

74HCT374							
CP to Qn propagation delay	t_{pd}	see Figure 6	$V_{CC}=4.5V$	-	-	40	ns
			$V_{CC}=5.0V; C_L=15pF$	-	-	-	ns
\overline{OE} to Qn enable time	t_{en}	$V_{CC}=4.5V$; see Figure 7		-	-	38	ns
\overline{OE} to Qn disable time	t_{dis}	$V_{CC}=4.5V$; see Figure 7		-	-	35	ns
transition time	t_t	Qn; $V_{CC}=4.5V$; see Figure 6		-	-	15	ns
pulse width	t_w	CP; HIGH or LOW; $V_{CC}=4.5V$; see Figure 6		24	-	-	ns
Dn to CP set-up time	t_{su}	$V_{CC}=4.5V$; see Figure 6		15	-	-	ns
Dn to CP hold time	t_h	$V_{CC}=4.5V$; see Figure 6		5	-	-	ns
maximum frequency	f_{max}	CP input; see Figure 6	$V_{CC}=4.5V$	21	-	-	MHz
			$V_{CC}=5.0V; C_L=15pF$	-	-	-	MHz
power dissipation capacitance	C_{PD}	per flip-flop; $V_I=GND$ to $V_{CC}-1.5V$		-	-	-	pF

Note:

- t_{pd} is the same as t_{PLH} and t_{PHL} .
- t_{en} is the same as t_{PZL} and t_{PZH} .
- t_{dis} is the same as t_{PLZ} and t_{PHZ} .
- t_t is the same as t_{THL} and t_{TLH} .
- C_{PD} is used to determine the dynamic power dissipation (P_D in uW).
 $P_D = C_{PD} \times V_{CC}^2 \times f_i \times N + \sum (C_L \times V_{CC}^2 \times f_o)$ where:
 f_i = input frequency in MHz; V_{CC} = supply voltage in V;
 f_o = output frequency in MHz; N = number of inputs switching;
 C_L = output load capacitance in pF; $\sum (C_L \times V_{CC}^2 \times f_o)$ = sum of outputs.

Testing Circuit

AC Testing Circuit

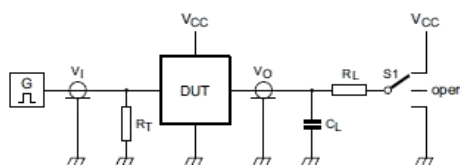
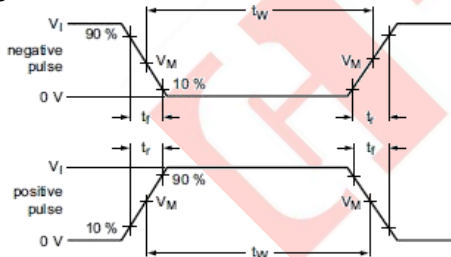

Definitions for test circuit:

R_L = Load resistance.

C_L = Load capacitance including jig and probe capacitance.

R_T = Termination resistance should be equal to the output impedance Z_o of the pulse generator. S_1 = Test selection switch.

Figure 5. Test circuit for measuring switching times

AC Testing Waveforms

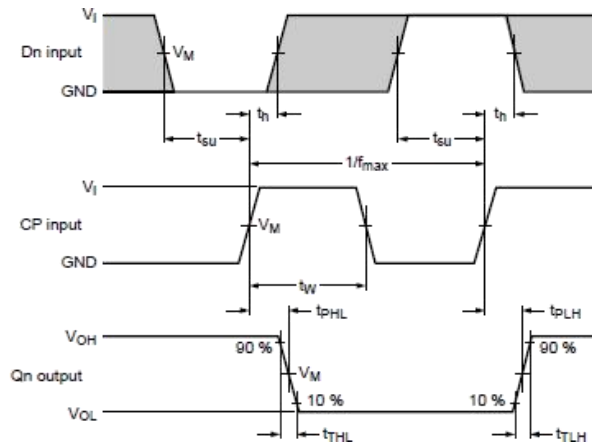

Figure 6. Clock input (CP) to output (Qn) propagation delay, clock pulse width, data (Dn) to clock (CP) set-up and hold times, output transition times (Qn) and maximum clock frequency



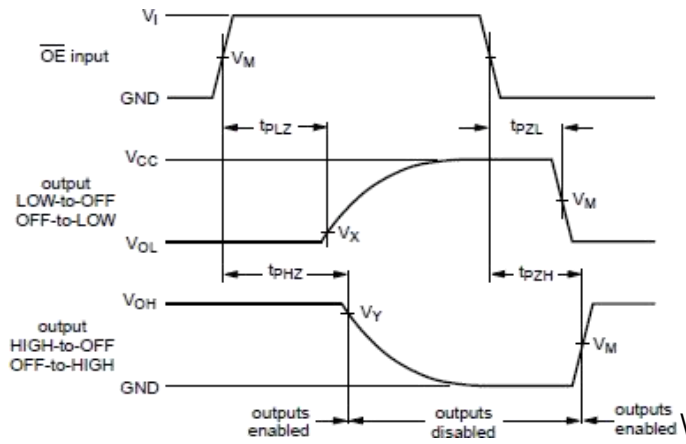

Figure 7.3-state enable and disable times

Measurement Points

Type	Input		Output		
	V_I	V_M	V_M	V_X	V_Y
74HC374	GND to V_{CC}	$0.5 \times V_{CC}$	$0.5 \times V_{CC}$	$0.1 \times V_{CC}$	$0.9 \times V_{CC}$
74HCT374	GND to 3V	1.3V	1.3V	$0.1 \times V_{CC}$	$0.9 \times V_{CC}$

Test Data

Type	Input		Load		S1 position		
	V_I	t_r, t_f	C_L	R_L	t_{PHL}, t_{PLH}	t_{PZH}, t_{PHZ}	t_{PZL}, t_{PLZ}
74HC374	GND to V_{CC}	6ns	15pF, 50pF	1k Ω	open	GND	V_{CC}
74HCT374	GND to 3V	6ns	15pF, 50pF	1k Ω	open	GND	V_{CC}

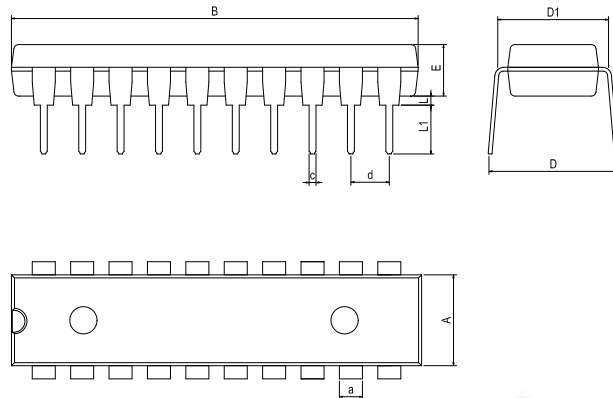
Physical Dimensions
DIP20

Dimensions In Millimeters(DIP20)										
Symbol:	A	B	D	D1	E	L	L1	a	c	d
Min:	6.10	24.95	8.40	7.42	3.10	0.50	3.00	1.50	0.40	2.54 BSC
Max:	6.68	26.55	9.00	7.82	3.55	0.70	3.60	1.55	0.50	

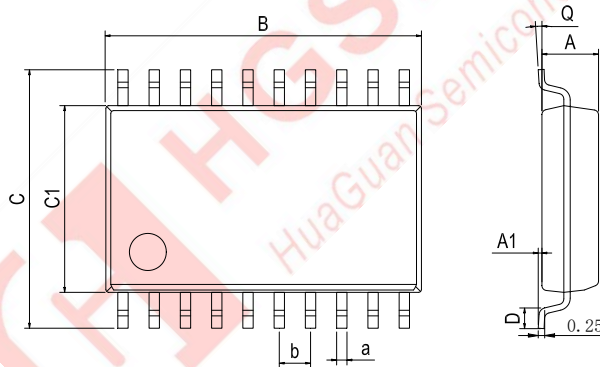
SOP20

Dimensions In Millimeters(SOP20)									
Symbol:	A	A1	B	C	C1	D	Q	a	b
Min:	2.10	0.05	12.50	10.21	7.40	0.45	0°	0.35	1.27 BSC
Max:	2.50	0.25	13.00	10.61	7.60	1.25	8°	0.45	

TSSOP20

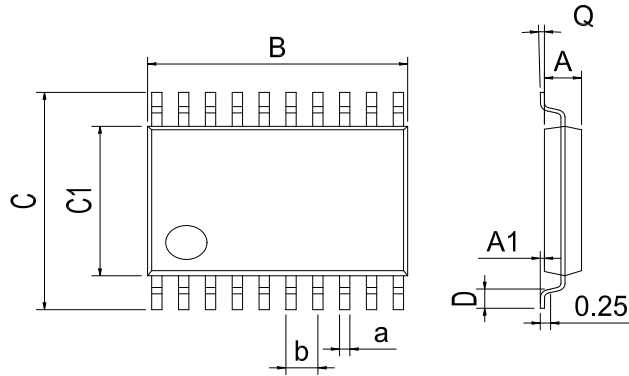

Dimensions In Millimeters(TSSOP20)									
Symbol:	A	A1	B	C	C1	D	Q	a	b
Min:	0.85	0.05	6.40	6.20	4.30	0.40	0°	0.20	0.65 BSC
Max:	1.05	0.20	6.60	6.60	4.50	0.80	8°	0.25	



IMPORTANT STATEMENT:

Huaguan Semiconductor Co,Ltd. reserves the right to change the products and services provided without notice. Customers should obtain the latest relevant information before ordering, and verify the timeliness and accuracy of this information.

Customers are responsible for complying with safety standards and taking safety measures when using our products for system design and machine manufacturing to avoid potential risks that may result in personal injury or property damage.

Our products are not licensed for applications in life support, military, aerospace, etc., so we do not bear the onsequences of the application of these products in these fields.

Huaguan Semiconductor Co,Ltd. the performance of the semiconductor products produced by the company can reach the performance indicators that can be applied at the time of sales. The use of testing and other quality control technologies is limited to the quality assurance scope of Huaguan semiconductor. Not all parameters of each device need to be tested. The above documents are for reference only, and all are subject to the physical parameters.

Our documentation is only permitted to be copied without any tampering with the content, so we do not accept any responsibility or liability for the altered documents.

X-ON Electronics

Largest Supplier of Electrical and Electronic Components

Click to view similar products for [Flip-Flops](#) category:

Click to view products by [HGSEMI](#) manufacturer:

Other Similar products are found below :

[74F574SC](#) [TC7W74FUTE12LF](#) [NLV14013BDR2G](#) [NLV74HC74ADR2G](#) [MC10EP131MNG](#) [MC74AC74DTR2](#) [CD4013BMT/TR](#)
[74VHC574FT\(BJ\)](#) [U74AHC14G-P14-R](#) [U74HC14G-S14-R](#) [CD40106BE](#) [HT4093ARZ](#) [74LVC1G80GW-Q100,1](#) [CD4013](#) [U74HC74G-P14-](#)
[R](#) [AIP74HC574SA20.TR](#) [74HC123MT/TR](#) [74HC374M/TR](#) [74HC123M/TR](#) [CD40106DMT/TR](#) [CD40106DE](#) [CD4538BMT/TR](#)
[MC74HC73ADG](#) [MC74HC73ADR2G](#) [74LCX16374MTDX](#) [74LVT74D,118](#) [74VHCT9273FT\(BJ\)](#) [JM38510/37202BEA](#) [MM74HC374WM](#)
[74ALVCH162374PAG](#) [74LVC1G175GS,132](#) [74LVX74MTCX](#) [TC7WZ74FK,LJ\(CT](#) [JM38510/30106BEA](#) [JM38510/00204BEA](#)
[MM74HCT273WM](#) [SN74LVC74AD](#) [MC74HC73ADTR2G](#) [SN74HC273DWR](#) [M74HC374RM13TR](#) [M74HC175B1R](#) [M74HC174RM13TR](#)
[74ALVTH32374ZKER](#) [74AUP1G74DC,125](#) [74VHC374FT\(BJ\)](#) [74VHCV374FT\(BJ\)](#) [74VHCV574FT\(BJ\)](#) [SN74LVC74ADR](#)
[SN74HC574PWR](#) [SN74HC374AN](#)