

- ※ **Qualified for Automotive Applications**
- ※ **Wide Analog Input Voltage Range of ± 5 V Max**
- ※ **Low ON Resistance**
 - **70 Ω Typical ($V_{CC} - V_{EE} = 4.5$ V)**
 - **40 Ω Typical ($V_{CC} - V_{EE} = 9$ V)**
- ※ **Low Crosstalk Between Switches**
- ※ **Fast Switching and Propagation Speeds**
- ※ **Break-Before-Make Switching**
- ※ **Operation Control Voltage = 2 V to 6 V**
- ※ **Switch Voltage = 0 V to 10 V**
- ※ **High Noise Immunity $N_{IL} = 30\%$, $N_{IH} = 30\%$ of V_{CC} , $V_{CC} = 5$ V**

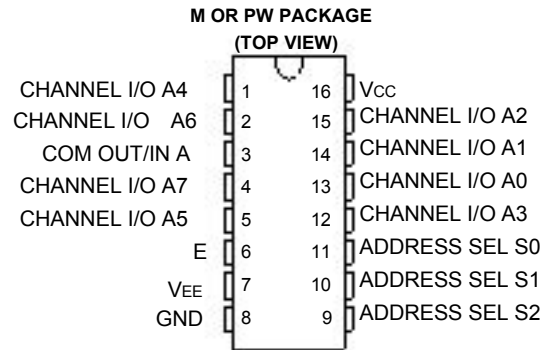

description

This device is a digitally controlled analog switch that utilizes silicon-gate CMOS technology to achieve operating speeds similar to LSTTL, with the low power consumption of standard CMOS integrated circuits.

This analog multiplexer/demultiplexer controls analog voltages that may vary across the voltage supply range (i.e., V_{CC} to V_{EE}). These bidirectional switches allow any analog input to be used as an output and vice versa. The switches have low ON resistance and low OFF leakages. In addition, the device has an enable control (E) that, when high, disables all switches to their OFF state.

FUNCTION TABLE

INPUTS				ON CHANNEL(S)
\bar{E}	S ₂	S ₁	S ₀	
L	L	L	L	A0
L	L	L	H	A1
L	L	H	L	A2
L	L	H	H	A3
L	H	L	L	A4
L	H	L	H	A5
L	H	H	L	A6
L	H	H	H	A7
H	X	X	X	None

X = Don't care

logic diagram (positive logic)

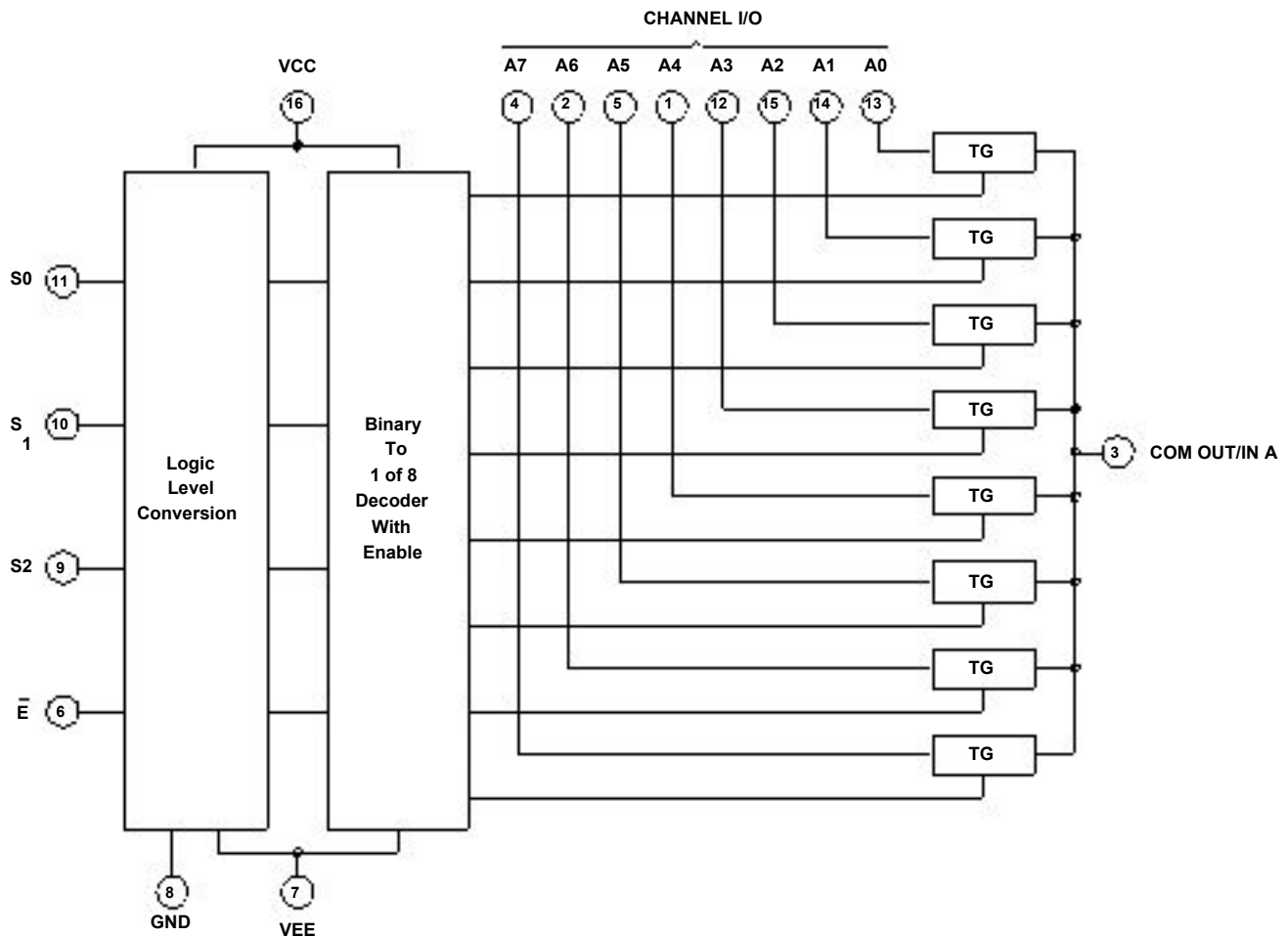

absolute maximum ratings over operating free-air temperature range (unless otherwise noted),[†]

Supply voltage range, $V_{CC} - V_{EE}$ (see Note 1)	-0.5 V to 10.5 V
Supply voltage range, V_{CC}	-0.5 V to 7 V
Supply voltage range, V_{EE}	+0.5 V to -7 V
Input clamp current, I_{IK} ($V_I < -0.5$ V or $V_I > V_{CC} + 0.5$ V)	± 20 mA
Output clamp current, I_{OK} ($V_O < V_{EE} - 0.5$ V or $V_O > V_{CC} + 0.5$ V)	± 20 mA
Switch current ($V_I > V_{EE} - 0.5$ V or $V_I < V_{CC} + 0.5$ V)	± 25 mA
Continuous current through V_{CC} or GND	± 50 mA
V_{EE} current, I_{EE}	-20 mA
Package thermal impedance, θ_{JA} (see Note 2):	M package	73°C/W
	PW package	108°C/W
Maximum junction temperature, T_J	50°C
Lead temperature (during soldering):		
At distance 1/16 ± 1/32 inch (1.59 ± 0.79 mm) from case for 10 s max	300°C
Storage temperature range, T_{stg}	-65°C to 150°C

[†] Stresses beyond those listed under "absolute maximum ratings" may cause permanent damage to the device. These are stress ratings only, and functional operation of the device at these or any other conditions beyond those indicated under "recommended operating conditions" is not implied. Exposure to absolute-maximum-rated conditions for extended periods may affect device reliability.

- NOTES: 1. All voltages referenced to GND unless otherwise specified.
2. The package thermal impedance is calculated in accordance with JESD 51-7.

recommended operating conditions (see Note 3)

		MIN	MAX	UNIT	
V_{CC}	Supply voltage (see Note 4)	2	6	V	
	Supply voltage, $V_{CC} - V_{EE}$ (see Figure 1)	2	10	V	
V_{EE}	Supply voltage, (see Note 4 and Figure 2)	0	-6	V	
V_{IH}	High-level input voltage High level	$V_{CC} = 2$ V	1.5	V	
		$V_{CC} = 4.5$ V	3.15		
		$V_{CC} = 6$ V	4.2		
V_{IL}	Low-level input voltage Low level	$V_{CC} = 2$ V	0.5	V	
		$V_{CC} = 4.5$ V	1.35		
		$V_{CC} = 6$ V	1.8		
V_I	Input control voltage	0	V_{CC}	V	
V_{ic}	Analog switch I/O voltage	V_{EE}	V_{CC}	V	
t_t	Input transition (rise and fall) time	$V_{CC} = 2$ V	0	1000	ns
		$V_{CC} = 4.5$ V	0	500	
		$V_{CC} = 6$ V	0	400	
T_A	Operating free-air temperature	-40	125	°C	

- NOTES: 3. All unused inputs of the device must be held at V_{CC} or GND to ensure proper device operation. Refer to the TI application report, *Implications of Slow or Floating CMOS Inputs*, literature number SCBA004.
4. In certain applications, the external load resistor current may include both V_{CC} and signal-line components. To avoid drawing V_{CC} current when switch current flows into the transmission gate inputs, the voltage drop across the bidirectional switch must not exceed 0.6 V (calculated from r_{on} values shown in electrical characteristics table). No V_{CC} current flows through R_L if the switch current flows into the COM OUT/IN A terminal.

recommended operating area as a function of supply voltages

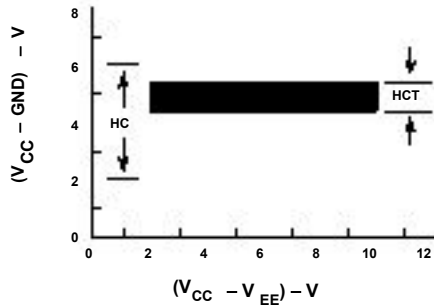

Figure 1

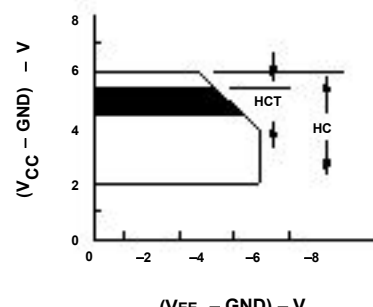

Figure 2

electrical characteristics over recommended operating free-air temperature range (unless otherwise noted)

PARAMETER	TEST CONDITIONS	VEE	Vcc	T _A = 25°C			T _A = -40°C TO 125°C		UNIT	
				MIN	TYP	MAX	MIN	MAX		
R _{on}	I _O = 1 mA, V _I = V _{IH} or V _{IL} , See Figure 8	V _{IS} = V _{CC} or V _{EE}	0 V	4.5 V	70	160	240		Ω	
			0 V	6 V	60	140	210			
			-4.5 V	4.5 V	40	120	180			
		V _{IS} = V _{CC} to V _{EE}	0 V	4.5 V	90	180	270			
			0 V	6 V	80	160	240			
			-4.5 V	4.5 V	45	130	195			
Δ R _{on}	Between any two channels	0 V	4.5 V	10					Ω	
		0 V	6 V	8.5						
		-4.5 V	4.5 V	5						
I _{Iz}	For switch OFF: When V _{IS} = V _{CC} , V _{OS} = V _{EE} ; When V _{IS} = V _{EE} , V _{OS} = V _{CC} . For switch ON: All applicable combinations of V _{IS} and V _{OS} voltage levels, V _I = V _{IH} or V _{IL}	0 V	6 V	±0.2			±2		αA	
		-5 V	5 V	±0.4			±4			
I _{IL}	V _I = V _{CC} or GND	0 V	6 V	±0.1			±1		αA	
I _{CC}	I _O = 0, V _I = 0, or GND = V _{CC} .	When V _{IS} = V _{EE} , V _{OS} = V _{CC}	0 V	6 V	8			160		αA
		When V _{IS} = V _{CC} , V _{OS} = V _{EE}	-5 V	5 V	16			320		

switching characteristics over recommended operating free-air temperature range (unless otherwise noted) (see Figure 7)

PARAMETER	FROM (INPUT)	TO (OUTPUT)	LOAD CAPACITANCE	V _{EE}	V _{CC}	T _A = 25°C			T _A = -40°C TO 125°C	UNIT
						MIN	TYP	MAX	MIN	
t _{pd}	IN	OUT	C _L = 15 pF		5 V	4			MAX	ns
			C _L = 50 pF	0 V	2 V	60			90	ns
					4.5 V	12			18	
					6 V	10			15	
					-4.5 V	4.5 V			8	
t _{en}	ADDRESS SEL or E ⁺	OUT	C _L = 15 pF		5 V	19				ns
			C _L = 50 pF	0 V	2 V	225			340	
					4.5 V	45			68	
					6 V	38			57	
					-4.5 V	4.5 V			32	
t _{dis}	ADDRESS SEL or E ⁺	OUT	C _L = 15 pF		5 V	19				ns
			C _L = 50 pF	0 V	2 V	225			340	
					4.5 V	45			68	
					6 V	38			57	
					-4.5 V	4.5 V			32	
C _i	Control		C _L = 50 pF					10	10	pF

operating characteristics, V_{CC} = 5 V, T_A = 25°C, Input t_r, t_f = 6 ns

PARAMETER	TYP	UNIT
C _{pd} Power dissipation capacitance (see Note 5)	50	pF

NOTE 5: C_{pd} is used to determine the dynamic power consumption, per package.

$$P_D = C_{pd} V_{CC}^2 f_i + \sum (C_L + C_S) V_{CC}^2 f_O$$

f_O = output frequency

f_i = input frequency

C_L = output load capacitance

C_S = switch capacitance

V_{CC} = supply voltage

analog channel characteristics, $T_A = 25^\circ\text{C}$

PARAMETER	TEST CONDITIONS	VEE	Vcc	MIN	TYP	MAX	UNIT
C_I	Switch input capacitance				5		pF
C_{COM}	Common output capacitance				25		pF
f_{max}	Minimum switch frequency response at -3 dB	See Figure 3 and Figure 9, and Notes 6 and 7	-2.25 V	2.25 V	145		MHz
			-4.5 V	4.5 V	180		
	Sine wave distortion Sine-wave	See Figure 4	-2.25 V	2.25 V	0.035		%
			-4.5 V	4.5 V	0.018		
E or ADDRESS SEL to switch feed-through noise	See Figure 55, and Notes 7 and 8		-2.25 V	2.25 V	(TBD)		mV
			-4.5 V	4.5 V	(TBD)		
Switch OFF signal feed through	See Figure 6 and Figure 10, and Notes 7 and 8		-2.25 V	2.25 V	-73		dB
			-4.5 V	4.5 V	-75		

- NOTES:
- Adjust input voltage to obtain 0 dBm at V_{OS} for $f_{IN} = 1$ MHz.
 - V_{IS} is centered at $(V_{CC} - V_{EE})/2$.
 - Adjust input for 0 dBm.

PARAMETER MEASUREMENT INFORMATION

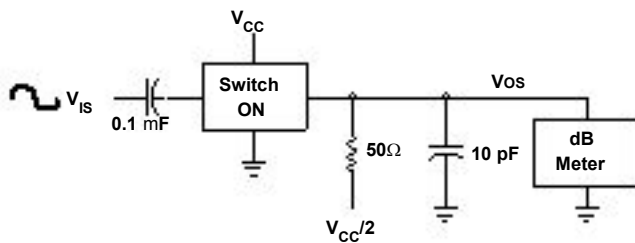

Figure 3. Frequency-Response Test Circuit

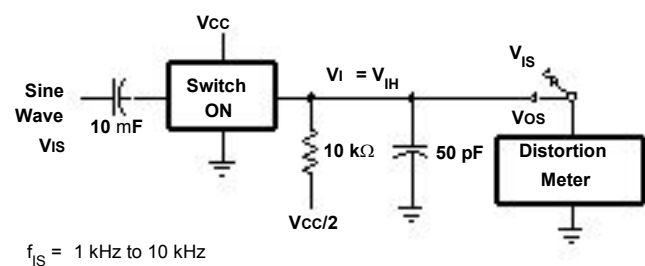

Figure 4. Sine-Wave Distortion Test Circuit

PARAMETER MEASUREMENT INFORMATION

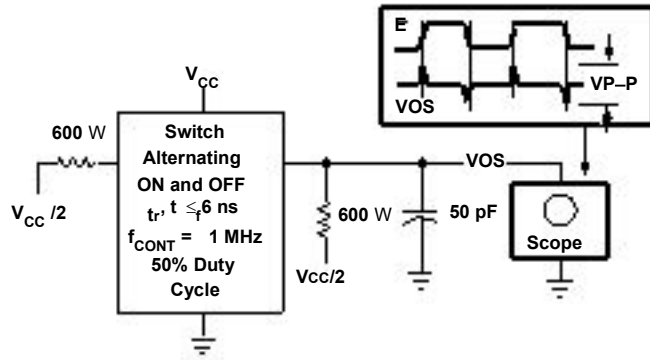

Figure 5. Control to Switch Feedthrough Noise Test Circuit

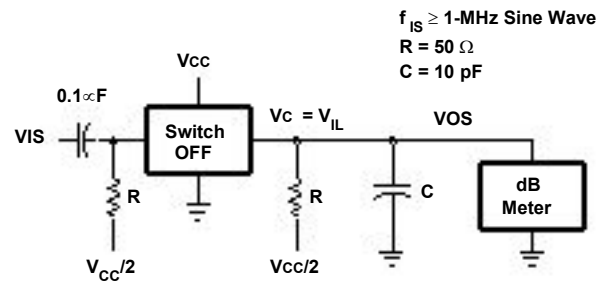
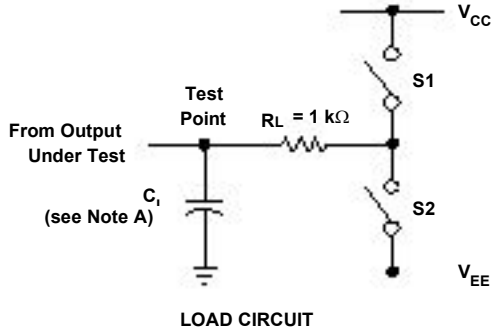
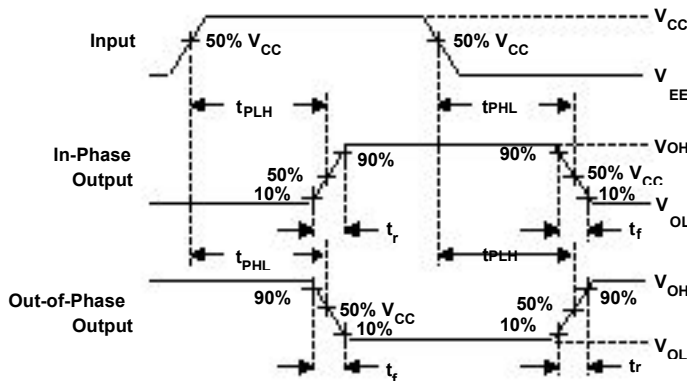

Figure 6. Switch OFF Signal Feedthrough Test Circuit

PARAMETER MEASUREMENT INFORMATION



PARAMETER		S1	S2
t_{en}	t_{DZH}	Open	Closed
	t_{PZL}	Closed	Open
t_{dis}	t_{PHZ}	Open	Closed
	t_{PLZ}	Closed	Open
t_{pd}		Open	Open



VOLTAGE WAVEFORMS
PROPAGATION DELAY AND OUTPUT TRANSITION TIMES

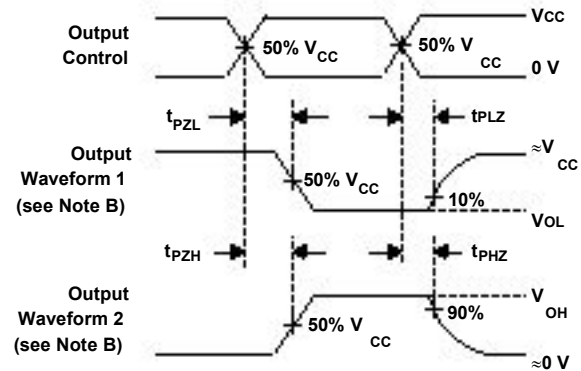

VOLTAGE WAVEFORMS
OUTPUT ENABLE AND DISABLE TIMES

- NOTES:
- A. C_1 includes probe and test-fixture capacitance.
 - B. Waveform 1 is for an output with internal conditions such that the output is low except when disabled by the output control. Waveform 2 is for an output with internal conditions such that the output is high except when disabled by the output control.
 - C. Phase relationships between waveforms were chosen arbitrarily. All input pulses are supplied by generators having the following characteristics: $PRR \leq 1\text{ MHz}$, $Z_O = 50\ \Omega$, $t_r = 6\text{ ns}$, $t_f = 6\text{ ns}$.
 - D. For clock inputs, f_{max} is measured with the input duty cycle at 50%.
 - E. The outputs are measured one at a time with one input transition per measurement.
 - F. t_{PLZ} and t_{PHZ} are the same as t_{dis} .
 - G. t_{PZL} and t_{PZH} are the same as t_{en} .
 - H. t_{PLH} and t_{PHL} are the same as t_{pd} .

Figure 7. Load Circuit and Voltage Wavefor

TYPICAL CHARACTERISTICS

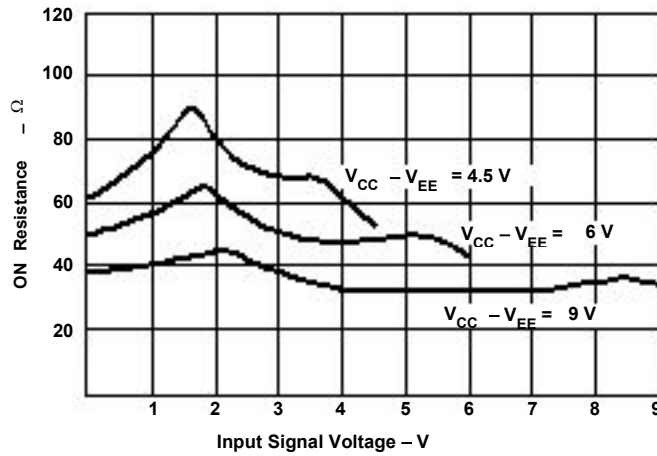

Figure 8. Typical ON Resistance vs Input Signal Voltage

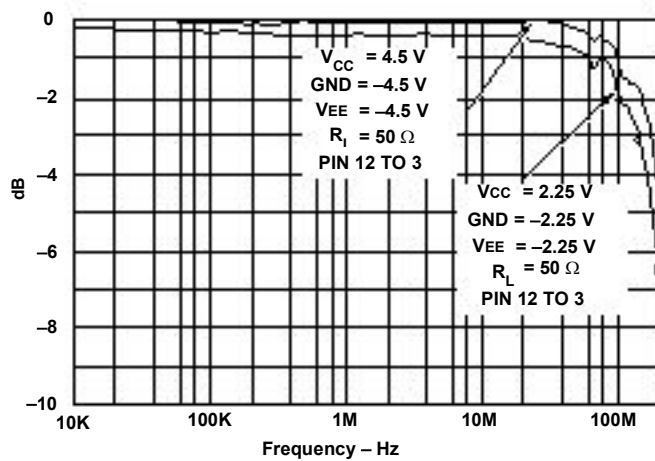

Figure 9. Channel ON Bandwidth

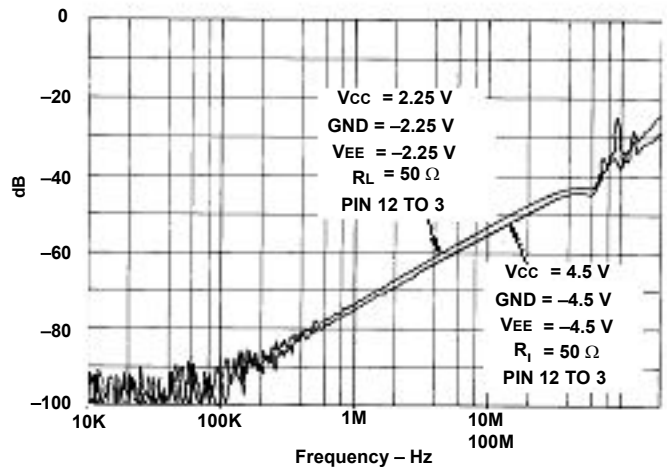

Figure 10. Channel OFF Feedthrough

X-ON Electronics

Largest Supplier of Electrical and Electronic Components

Click to view similar products for [Switch ICs](#) - Various category:

Click to view products by [HGSEMI](#) manufacturer:

Other Similar products are found below :

[BCM56226B0IPBG](#) [LC824206XA-VH](#) [80HCPS1432RM](#) [FSA806UMX](#) [BCM56152A0IFSBLG](#) [80HCPS1432CHMHI](#) [MAX4936ACTO+](#)
[80HSPS1616CHMGI](#) [NL3S325FCT2G](#) [BCM56152A0KFSBLG](#) [BCM56150A0KFSBLG](#) [BCM56024B0KPBG](#) [CPC7583BA](#) [NC7SZ157P6X](#)
[ACST12-7CG-TR](#) [FSA9280AUMX](#) [MAX14626ETT+T](#) [NL7SZ19DFT2G](#) [SRC0CS25D](#) [MAX14808ETK](#) [MAX4937CTN+](#) [DG2788ADN-](#)
[T1-GE4](#) [DGQ2788AEN-T1-GE4](#) [LTC6943IGN#PBF](#) [MCZ33999EKR2](#) [LTC1471CS#PBF](#) [LTC1472CS#PBF](#) [LTC1043CSW#PBF](#)
[PI4MSD5V9548ALEX](#) [NCX8200UKZ](#) [LTC6943HGN#PBF](#) [PI3CH480QE](#) [HT1204](#) [89H48T12G2ZCBLG](#) [PI3C3245QE](#) [ADG409BRZ-](#)
[REEL7](#) [ADG5462FBRUZ-RL7](#) [ADN4604ASVZ](#) [LTC1043CN](#) [LTC1043CN#PBF](#) [LTC1470ES8#PBF](#) [PI4MSD5V9548AZDEX](#) [AP2280-](#)
[2FMG-7](#) [AZV5001RA4-7](#) [PI3B3253QEX](#) [PI3CH480QEX](#) [74HC4053N](#) [74HC139N](#) [74HC138N](#) [XD74LS138](#)