

## CMOS 8-Input NOR/OR

High-Voltage Types(20-Volt Rating)

### DESCRIPTION

CD4078B NOR/OR Gate provides the system designer with direct implementation of the positive logic 8-input NOR and OR functions and supplements the existing family of CMOS gates.

The CD4078B types are supplied in 14-lead dual-in-line plastic packages (N suffix), 14-lead small-outline packages (M suffixes) and 14 lead thin shrink small-outline packages (MT suffixes).

### Features

- Medium-Speed Operation:  $t_{PHL}, t_{PLH} = 75\text{ns}$  (typ.) at  $V_{DD} = 10\text{V}$
- Buffered inputs and output
- 5V, 10V and 15V parametric ratings
- Standardized symmetrical output characteristics
- 100% tested for quiescent current at 20V
- Maximum input current of 1 $\mu\text{A}$  at 18V over full package-temperature range: 100nA at 18V and 25°C
- Noise margin (over full package-temperature range): 1V at  $V_{DD} = 5\text{V}$  2V at  $V_{DD} = 10\text{V}$  2.5V at  $V_{DD} = 15\text{V}$
- Meets all requirements of JEDEC Tentative Standard No. 13B "Standard Specifications for Description of B Series CMOS Devices"

### ORDERING INFORMATION

Device	Package Type	Marking	Packing	Packing Qty
CD4078BE	DIP14	CD4078BE	TUBE	1000pcs/box
CD4078BM /TR	SOP14	CD4078B	REEL	2500pcs/reel
CD4078BMT/TR	TSSOP14	CD4078B	REEL	2500pcs/reel

### CONNECTION DIAGRAM

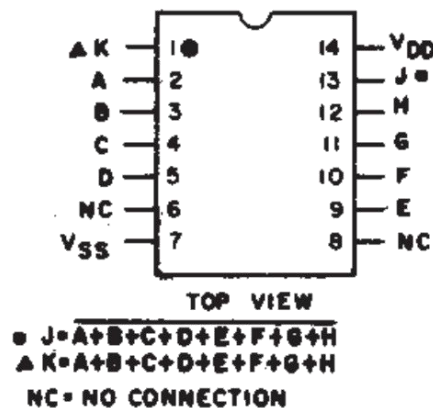

## FUNCTIONAL DIAGRAM

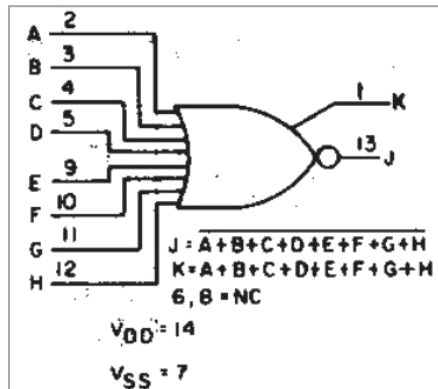

## ABSOLUTE MAXIMUM RATINGS

CONDITION		MIN	MAX
Voltages referenced to vss terminal		-0.5V	+20V
Input voltage range all inputs		-0.5V	$V_{dd}+0.5V$
DC input current any one input		±10mA	
Device dissipation per output transistor	for $t_a$ =full package-temperature range(all package types)	100mW	
	operating-temperature range( $T_A$ )	-40°C	+85°C
	storage temperature range( $T_{stg}$ )	-65°C	+150°C
Lead temperature(during soldering): at distance 1/16±1/32inch(1.59±0.79mm)from case for 10s max		+265°C	

## ORDERING INFORMATION

Device	Package Type	Marking	Packing	Packing Qty
CD4078BE	DIP14	CD4078BE	TUBE	1000pcs/box
CD4078BM /TR	SOP14	CD4078B	REEL	2500pcs/reel
CD4078BMT/TR	TSSOP14	CD4078B	REEL	2500pcs/reel

## RECOMMENDED OPERATING CONDIIIONS

For maximum reliability, nominal operating conditions should be selected so that operation is always within the following ranges:

CHARACTERISTIC	Min.	Max.	Units
Supply Voltage Range (For $T_A$ Full Package Temperature Range)	5	18	V

## DYNAMIC ELECTRICAL CHARACTERISTICS

At TA=25°C; Input tr tf=20ns, CL=50pf, RL=200kΩ

CHARACTERISTIC	TEST CONDITIONS	LIMITS		UNITS
	VDD VOLTSZ	TYP.	MAX.	
Propagation Delay Time, t <sub>PHL</sub> , t <sub>PLH</sub>	5	150	300	ns
	10	75	150	
	15	55	110	
Propagation Time, t <sub>PHL</sub> , t <sub>PLH</sub>	5	400	200	ns
	10	50	100	
	15	40	80	
Input Capacitance, C <sub>IN</sub>	Any Input	5	7.5	pF

## STATIC ELECTRICAL CHARACTERISTICS

CHARACTERISTIC	CONDITIONS			LIMITS AT INDICATED TEMPERATURES(°C)					UNITS
	V <sub>O</sub> (V)	V <sub>IN</sub> (V)	V <sub>DD</sub> (V)	+25					
				-40	+85	Min.		Typ.	
Quiescent Device Current, IDD Max.	—	0.5	5	0.25	7.5	—	0.01	0.25	μA
	—	0.10	10	0.5	15	—	0.01	0.5	
	—	0.15	15	1	30	—	0.01	1	
	—	0.20	20	5	150	—	0.02	5	
Output Low (Sink) Current I <sub>OL</sub> Min.	0.4	0.5	5	0.61	0.42	0.51	1		mA
	0.5	0.10	10	1.5	1.1	1.3	2.6		
	1.5	0.15	15	4	2.8	3.4	6.8		
Output High (Source) Current, I <sub>OH</sub> Min.	4.6	0.5	5	-0.61	-0.42	-0.51	-1		mA
	2.5	0.5	5	-1.8	-1.3	-1.6	-3.2		
	9.5	0.10	10	-1.5	-1.1	-1.3	-2.6		
	13.5	0.15	15	-4	-2.8	-3.4	-6.8		
Output Voltage Low Level, V <sub>OL</sub> Max.	—	0.5	5	0.05			0	0.05	V
	—	0.10	10	0.05			0	0.05	
	—	0.15	15	0.05			0	0.05	
Output Voltage High Level, V <sub>OH</sub> Min.	—	0.5	5	1.95		4.95	5		V
	—	0.10	10	9.95		9.95	10		
	—	0.15	15	14.95		14.95	15		
Input Low Voltage. V <sub>IL</sub> Max.	0.5	—	5	1.5		—	—	1.5	V
	4.5	—	5	1.5		—	—	1.5	
	1.9	—	10	3		—	—	3	
	1.5	—	15	4		—	—	4	
Input High Voltage. V <sub>IN</sub> Min.	0.5	—	5	3.5		3.5	—	—	V
	4.5	—	5	3.5		3.5	—	—	
	1.9	—	10	7		7	—	—	
	1.5	—	15	11		11	—	—	
Input Current V <sub>IN</sub> Max.		0.18	18	±0.1	±1	—	±10-5	±0.1	μA

TYPICAL CHARACTERISTIC

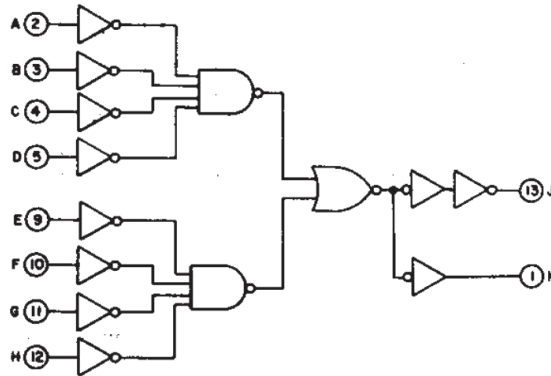

Fig.1-Logic diagram.

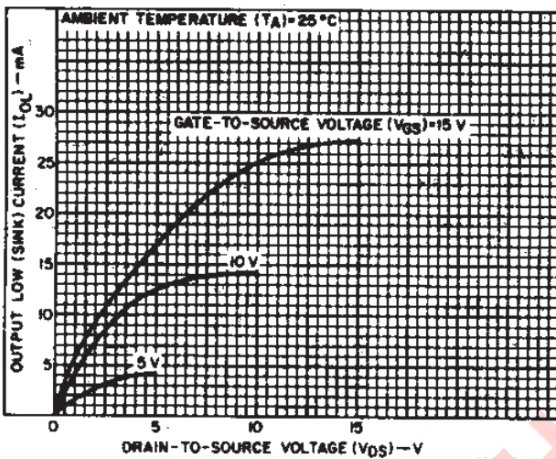

Fig.2-Typical output low(sink) current characteristics.

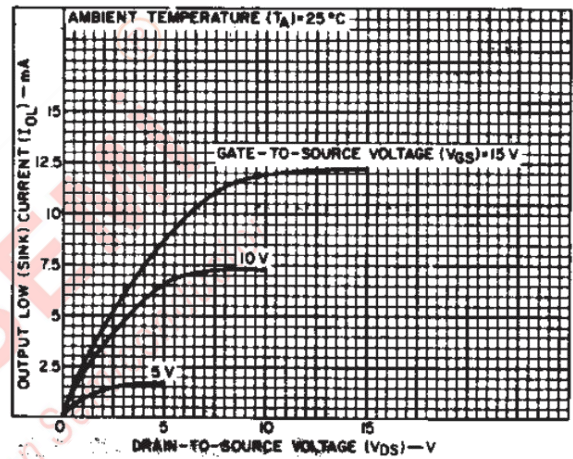

Fig.3-Minimum output low(sink) current characteristics.

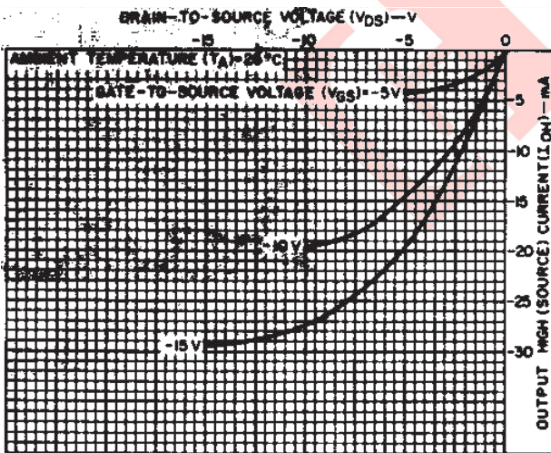

Fig.4 -Typical output high(souce)current characteristics.

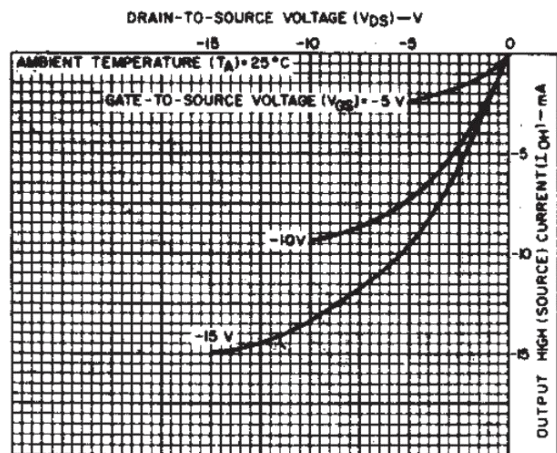

Fig.5 -Minimum output high(source)currnt characteristics.



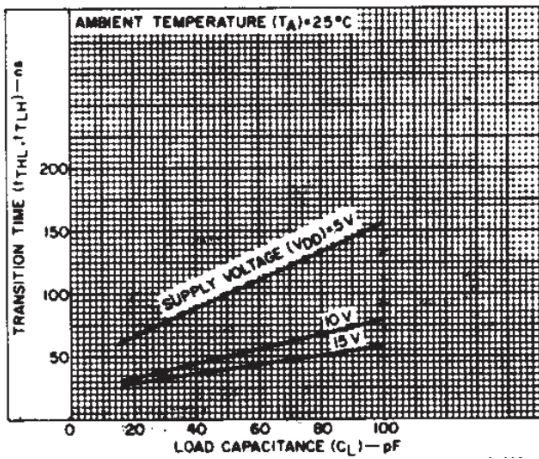

Fig.6 -Typical transition time as a function of load capacitance.

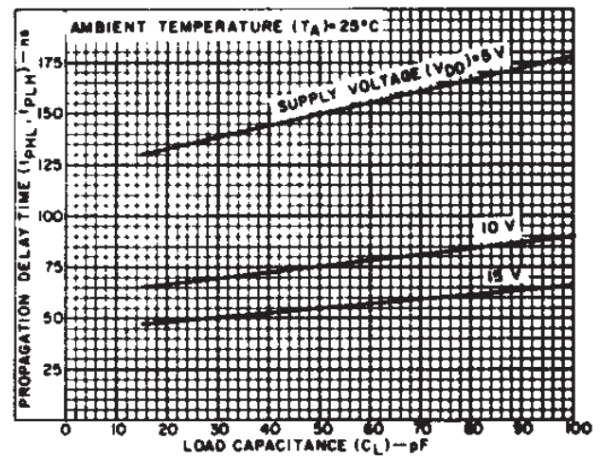

Fig.7 -Typical propagation delay time as a function of load capacitance.

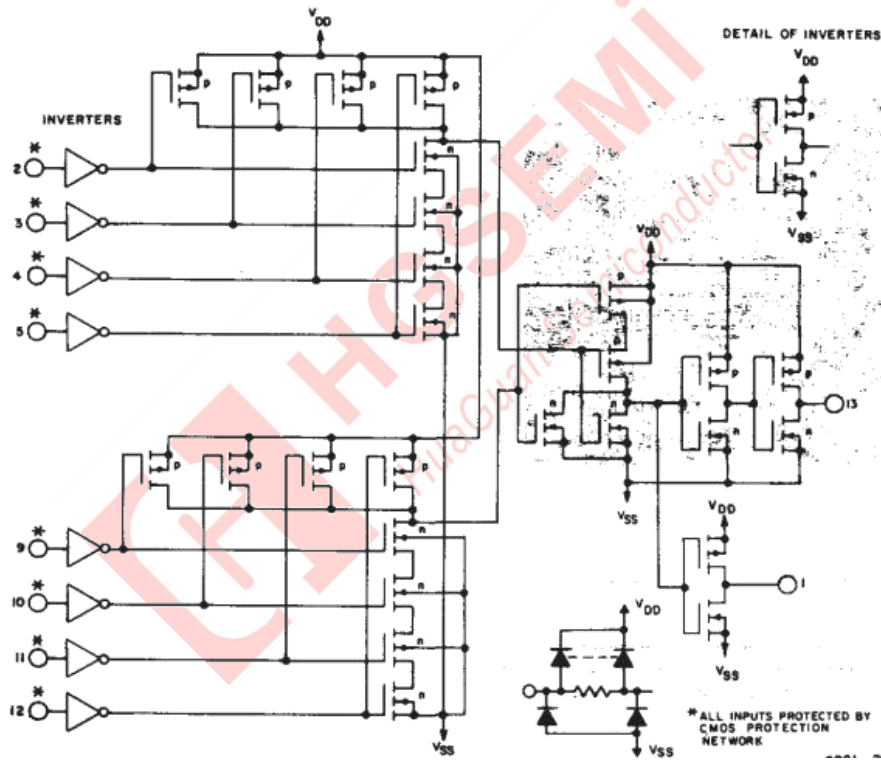

Fig.8 -Schematic diagram.

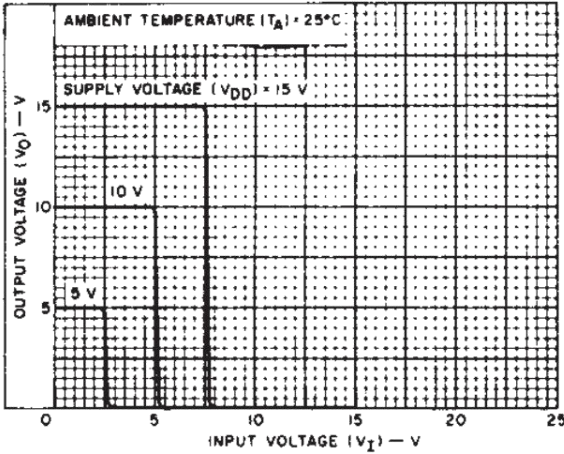

Fig.9 -Typical voltage transfer charac-teristics(NOR output).

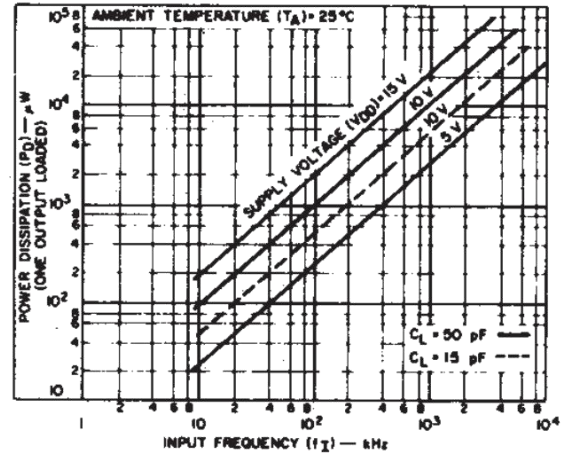

Fig.10 -Typical dynamic power dissipation as a function of frequency.

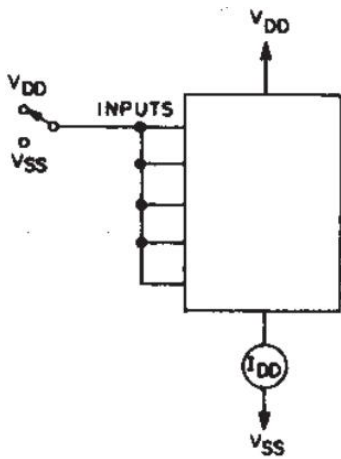

Fig.11 -Quiescent-device-current test circuit.

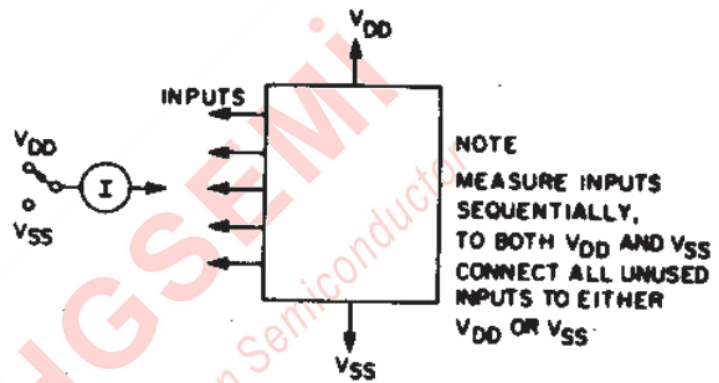

Fig.12 -Input current test circuit.

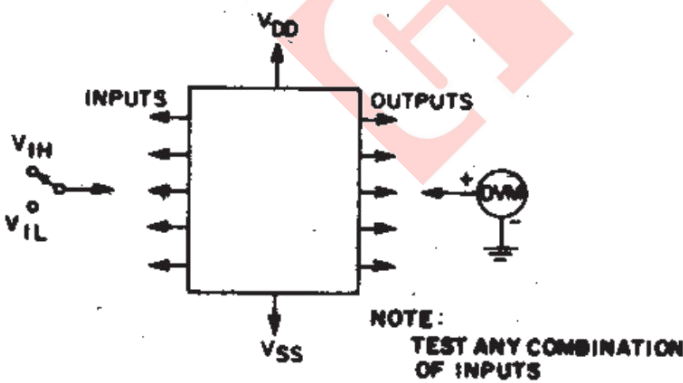

Fig.13 -Input voltage test circuit.

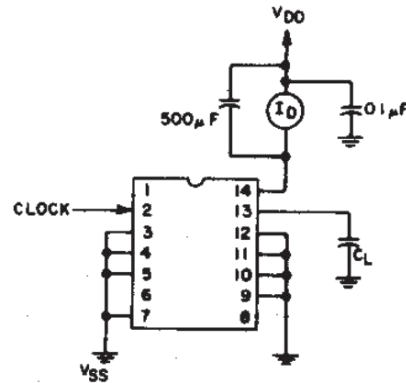
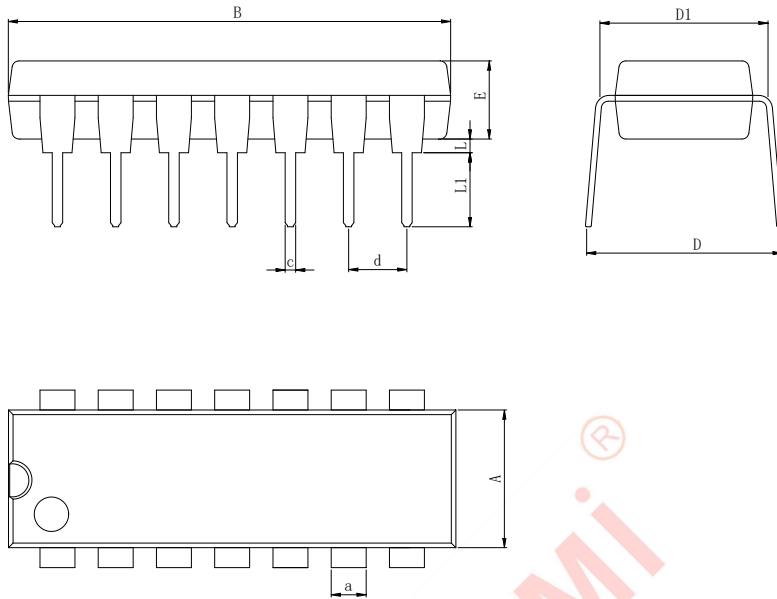

Fig.14 -Dynamic power dissipation test circuit

## Physical Dimensions

### DIP-14L



Dimensions In Millimeters(DIP14L)										
Symbol:	A	B	D	D1	E	L	L1	a	c	d
Min:	6.10	18.94	8.40	7.42	3.10	0.50	3.00	1.50	0.40	2.54 BSC
Max:	6.68	19.56	9.00	7.82	3.55	0.70	3.60	1.55	0.50	

### SOP14L

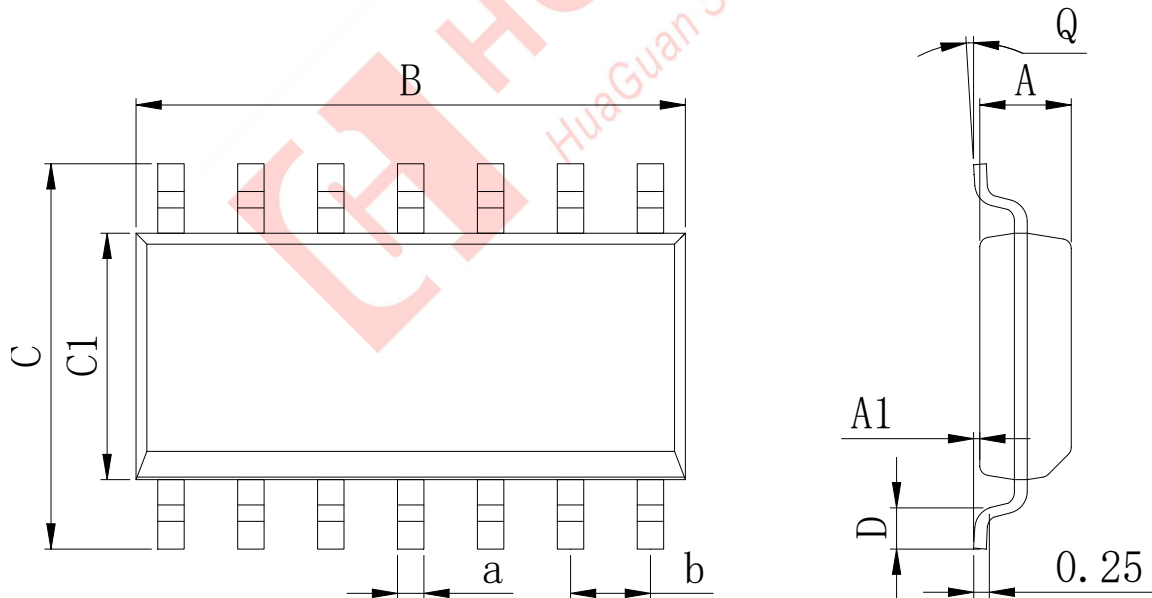

Dimensions In Millimeters(SOP14L)									
Symbol:	A	A1	B	C	C1	D	Q	a	b
Min:	1.35	0.05	8.55	5.80	3.80	0.40	0°	0.35	1.27 BSC
Max:	1.55	0.20	8.75	6.20	4.00	0.80	8°	0.45	

**Physical Dimensions**

TSSOP-14L

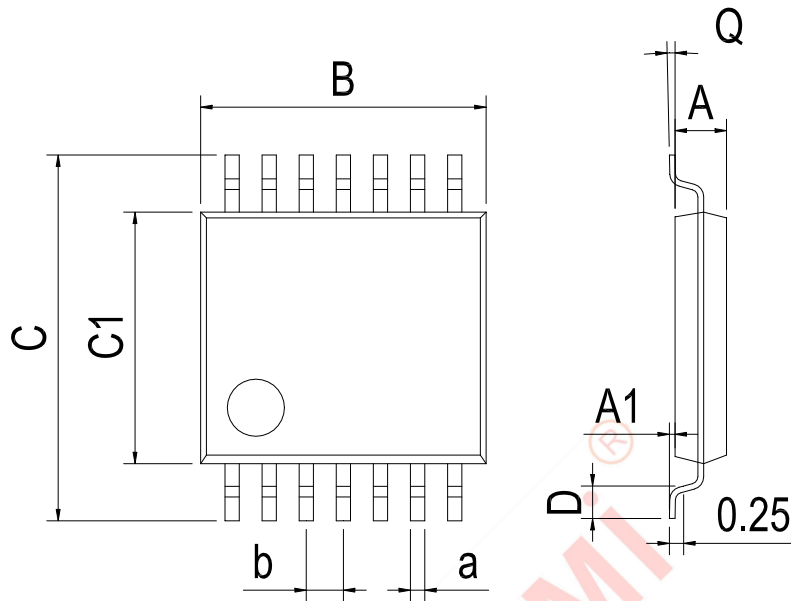

Dimensions In Millimeters(TSSOP14L)									
Symbol:	A	A1	B	C	C1	D	Q	a	b
Min:	0.85	0.05	4.90	6.20	4.30	0.40	0°	0.20	0.65 BSC
Max:	0.95	0.20	5.10	6.60	4.50	0.80	8°	0.25	



## **IMPORTANT STATEMENT:**

Huaguan Semiconductor Co,Ltd. reserves the right to change the products and services provided without notice. Customers should obtain the latest relevant information before ordering, and verify the timeliness and accuracy of this information.

Customers are responsible for complying with safety standards and taking safety measures when using our products for system design and machine manufacturing to avoid potential risks that may result in personal injury or property damage.

Our products are not licensed for applications in life support, military, aerospace, etc., so we do not bear the onsequences of the application of these products in these fields.

Huaguan Semiconductor Co,Ltd. the performance of the semiconductor products produced by the company can reach the performance indicators that can be applied at the time of sales. The use of testing and other quality control technologies is limited to the quality assurance scope of Huaguan semiconductor. Not all parameters of each device need to be tested. The above documents are for reference only, and all are subject to the physical parameters.

Our documentation is only permitted to be copied without any tampering with the content, so we do not accept any responsibility or liability for the altered documents.

## X-ON Electronics

Largest Supplier of Electrical and Electronic Components

*Click to view similar products for [Logic Gates](#) category:*

*Click to view products by [HGSEMI](#) manufacturer:*

Other Similar products are found below :

[74HC85N](#) [NL17SG32DFT2G](#) [NLV7SZ58DFT2G](#) [NLVHC1G08DFT1G](#) [CD4068BE](#) [TC7SET32FU\(T5L,JF\)](#) [NL17SG32P5T5G](#)  
[NL17SG86DFT2G](#) [NLV14001UBDR2G](#) [NLX1G11AMUTCG](#) [NLX1G97MUTCG](#) [74LS38](#) [74LVC1G08Z-7](#) [74LVC32ADTR2G](#) [CD4025BE](#)  
[MC74HCT20ADTR2G](#) [NLV17SZ00DFT2G](#) [NLV17SZ02DFT2G](#) [NLV17SZ126DFT2G](#) [NLV27WZ17DFT2G](#) [NLV74HC02ADR2G](#)  
[74HC32S14-13](#) [74LS133](#) [74LVC1G32Z-7](#) [74LVC1G86Z-7](#) [74LVC2G08RA3-7](#) [NLV74HC14ADR2G](#) [NLV74HC20ADR2G](#)  
[NLVVHC1G09DFT1G](#) [NLX2G86MUTCG](#) [NLU1G00AMUTCG](#) [74LVC2G32RA3-7](#) [74LVC2G00HD4-7](#) [NL17SG02P5T5G](#)  
[74LVC2G00HK3-7](#) [74LVC2G86HK3-7](#) [NL17SG08DFT2G](#) [NLVVHC1G14DFT2G](#) [NLX1G99DMUTWG](#) [NLVX1G11AMUTCG](#)  
[NLVVHC1G00DFT2G](#) [NLVHC1G08DFT2G](#) [NLV7SZ57DFT2G](#) [NLV74VHC04DTR2G](#) [NLV27WZ86USG](#) [NLV27WZ00USG](#)  
[NLU1G86CMUTCG](#) [NLU1G08CMUTCG](#) [NL17SZ32P5T5G](#) [NL17SZ00P5T5G](#)