

Features

- High Voltage Types (20V Rating)
- CD4518B Dual BCD Up Counter
- CD4520B Dual Binary Up Counter
- Medium Speed Operation: 6MHz Typical Clock Frequency at 10V
- Positive or Negative Edge Triggering
- Synchronous Internal Carry Propagation
- 100% Tested for Quiescent Current at 20V
- 5V, 10V and 15V Parametric Ratings
- Maximum Input Current of 1 μ A at 18V Over Full Package Temperature Range; 100nA at 18V and +25°C
- Noise Margin (Over Full Package/Temperature Range)
 - 1V at VDD = 5V
 - 2V at VDD = 10V
 - 2.5V at VDD = 15V
- Standardized Symmetrical Output Characteristics
- Meets All Requirements of JEDEC Tentative Standard No. 13B, "Standard Specifications for Description of 'B' Series CMOS Devices"

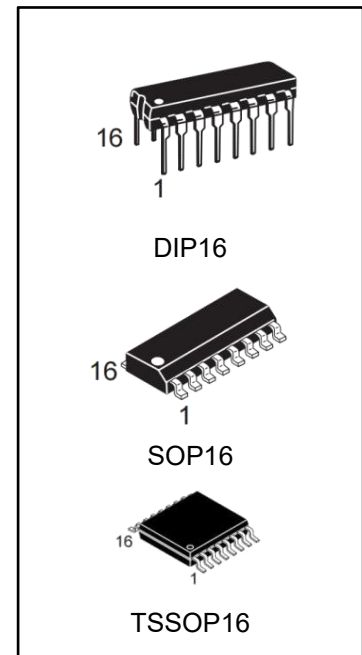

Ordering Information

DEVICE	Package Type	MARKING	Packing	Packing Qty
CD4518BE	DIP-16	CD4518B	TUBE	1000pcs/box
CD4520BE	DIP-16	CD4520B	TUBE	1000pcs/box
CD4518BM/TR	SOP-16	CD4518B	REEL	2500pcs/reel
CD4520BM/TR	SOP-16	CD4520B	REEL	2500pcs/reel
CD4518BMT/TR	TSSOP-16	CD4518B	REEL	2500pcs/reel
CD4520BMT/TR	TSSOP-16	CD4520B	REEL	2500pcs/reel

Description

CD4518B Dual BCD Up Counter and CD4520B Dual Binary Up Counter each consist of two identical, internally synchronous 4-stage counters. The counter stages are D-type flip-flops having interchangeable CLOCK and ENABLE lines for incrementing on either the positive-going or negative-going transition. For single unit operation the ENABLE input is maintained high and the counter advances on each positive-going transition of the CLOCK. The counters are cleared by high levels on their RESET lines.

The counter can be cascaded in the ripple mode by connecting Q4 to the enable input of the subsequent counter while the CLOCK input of the latter is held low.

Applications

- Multistage Synchronous Counting
- Multistage Ripple Counting
- Frequency Dividers

Pinout

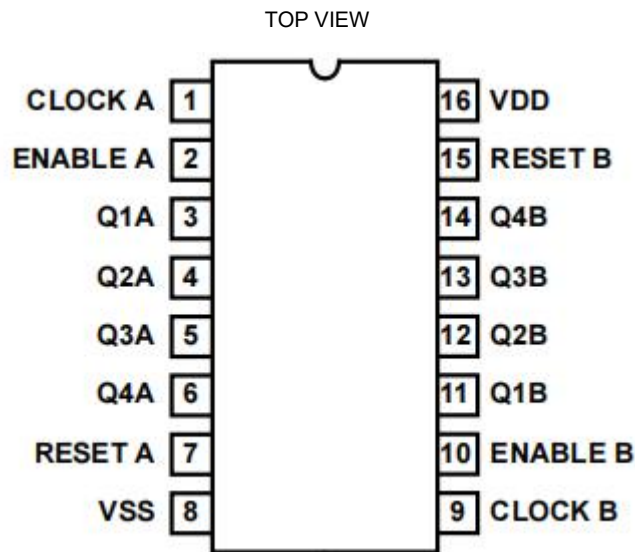

CD4518B/CD4520B

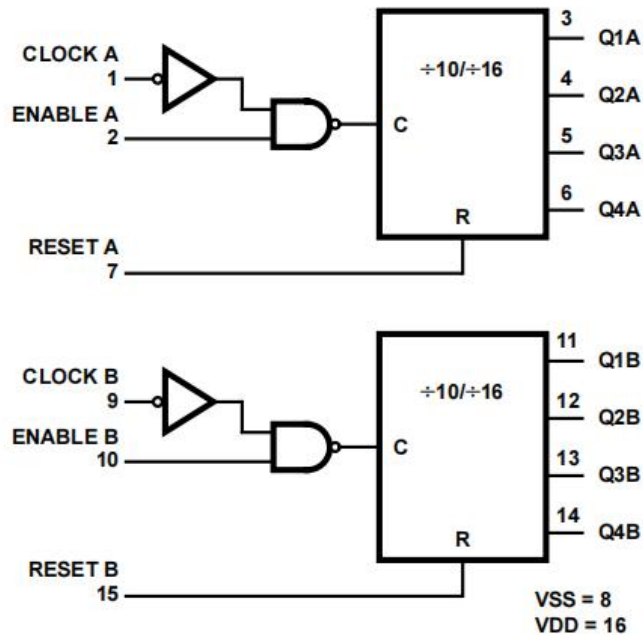
Functional Diagram

Absolute Maximum Ratings

Condition	Min	Max	UNITS
DC Supply Voltage Range, (VDD) (Voltage Referenced to VSS Terminals)	-0.5	+20	V
Input Voltage Range, All Inputs	-0.5	Vdd+0.5	V
DC Input Current, Any One Input	-10	+10	mA
Operating Temperature Range	-40	+85	°C
Storage Temperature Range (TSTG)	-65	+150	°C
Lead Temperature (During Soldering) At Distance (1.59mm ± 0.79mm) from case for 10s Maximum	-	+265	°C

DC ELECTRICAL PERFORMANCE CHARACTERISTICS

PARAMETER	SYMBOL	CONDITIONS (NOTE 1)		GROUP A SUBGROUPS	TEMPERATURE	LIMITS		UNITS
						MIN	MAX	
Supply Current	IDD	VDD = 20V, VIN = VDD or GND		1	+25°C	-	10	A
				2	+85°C	-	1000	A
		VDD = 18V, VIN = VDD or GND		3	-40°C	-	10	A
Input Leakage Current	IIL	VIN = VDD or GND	VDD = 20	1	+25°C	-100	-	nA
			VDD = 18V	2	+85°C	-1000	-	nA
				3	-40°C	-100	-	nA
Input Leakage Current	IIH	VIN = VDD or GND	VDD = 20	1	+25°C	-	100	nA
			VDD = 18V	2	+85°C	-	1000	nA
				3	-40°C	-	100	nA
Output Voltage	VOL15	VDD = 15V, No Load		1, 2, 3	+25°C, +85°C, -40°C	-	50	mV
Output Voltage	VOH15	VDD = 15V, No Load (Note 3)		1, 2, 3	+25°C, +85°C, -40°C	14.95	-	V
Output Current (Sink)	IOL5	VDD = 5V, VOUT = 0.4V		1	+25°C	0.53	-	mA
Output Current (Sink)	IOL10	VDD = 10V, VOUT = 0.5V		1	+25°C	1.4	-	mA
Output Current (Sink)	IOL15	VDD = 15V, VOUT = 1.5V		1	+25°C	3.5	-	mA
Output Current (Source)	IOH5A	VDD = 5V, VOUT = 4.6V		1	+25°C	-	-0.53	mA
Output Current (Source)	IOH5B	VDD = 5V, VOUT = 2.5V		1	+25°C	-	-1.8	mA
Output Current (Source)	IOH10	VDD = 10V, VOUT = 9.5V		1	+25°C	-	-1.4	mA
Output Current (Source)	IOH15	VDD = 15V, VOUT = 13.5V		1	+25°C	-	-3.5	mA
N Threshold Voltage	VNTH	VDD = 10V, ISS = -10μA		1	+25°C	-2.8	-0.7	V
P Threshold Voltage	VPTH	VSS = 0V, IDD = 10μA		1	+25°C	0.7	2.8	V
Functional	F	VDD = 2.8V, VIN = VDD or GND		7	+25°C	VOH > VDD/2	VOL < VDD/2	V
		VDD = 20V, VIN = VDD or GND		7	+25°C			
		VDD = 18V, VIN = VDD or GND		8A	+85°C			
		VDD = 3V, VIN = VDD or GND		8B	-40°C			
Input Voltage Low (Note 2)	VIL	VDD = 5V, VOH > 4.5V, VOL < 0.5V		1, 2, 3	+25°C, +85°C, -40°C	-	1.5	V
Input Voltage High (Note 2)	VIH	VDD = 5V, VOH > 4.5V, VOL < 0.5V		1, 2, 3	+25°C, +85°C, -40°C	3.5	-	V
Input Voltage Low (Note 2)	VIL	VDD = 15V, VOH > 13.5V, VOL < 1.5V		1, 2, 3	+25°C, +85°C, -40°C	-	4	V
Input Voltage High (Note 2)	VIH	VDD = 15V, VOH > 13.5V, VOL < 1.5V		1, 2, 3	+25°C, +85°C, -40°C	11	-	V

NOTES:

1. All voltages referenced to device GND, 100% testing being implemented.
2. Go/No Go test with limits applied to inputs.
3. For accuracy, voltage is measured differentially to VDD. Limit is 0.050V max.

AC ELECTRICAL PERFORMANCE CHARACTERISTICS

PARAMETER	SYMBOL	CONDITIONS (NOTE 1, 2)	GROUP A SUBGROUPS	TEMPERATURE	LIMITS		UNITS
					MIN	MAX	
Propagation Delay Clock to Output	TPHL1 TPLH1	VDD = 5V, VIN = VDD or GND	9	+25°C	-	560	ns
			10, 11	+85°C, -40°C	-	756	ns
Propagation Delay Reset to Output	TPHL2	VDD = 5V, VIN = VDD or GND	9	+25°C	-	650	ns
			10, 11	+85°C, -40°C	-	878	ns
Transition Time (Note 2)	TTHL TTLH	VDD = 5V, VIN = VDD or GND	9	+25°C	-	200	ns
			10, 11	+85°C, -40°C	-	270	ns
Maximum Clock Input Frequency	FCL	VDD = 5V, VIN = VDD or GND	9	+25°C	1.5	-	MHz
			10, 11	+85°C, -40°C	1.11	-	MHz

NOTES:

1. CL = 50pF, RL = 200K, Input TR, TF < 20ns.
2. -40°C and +85°C limits guaranteed, 100% testing being implemented.

ELECTRICAL PERFORMANCE CHARACTERISTICS

PARAMETER	SYMBOL	CONDITIONS	NOTES	TEMPERATURE	LIMITS		UNITS
					MIN	MAX	
Supply Current	IDD	VDD = 5V, VIN = VDD or GND	1, 2	-40°C, +25°C	-	5	A
				+85°C	-	150	A
		VDD = 10V, VIN = VDD or GND	1, 2	-40°C, +25°C	-	10	A
				+85°C	-	300	A
		VDD = 15V, VIN = VDD or GND	1, 2	-40°C, +25°C	-	10	A
				+85°C	-	600	A
Output Voltage	VOL	VDD = 5V, No Load	1, 2	+25°C, +85°C, -40°C	-	50	mV
Output Voltage	VOL	VDD = 10V, No Load	1, 2	+25°C, +85°C, -40°C	-	50	mV
Output Voltage	VOH	VDD = 5V, No Load	1, 2	+25°C, +85°C, -40°C	4.95	-	V
Output Voltage	VOH	VDD = 10V, No Load	1, 2	+25°C, +85°C, -40°C	9.95	-	V
Output Current (Sink)	IOL5	VDD = 5V, VOUT = 0.4V	1, 2	+85°C	0.36	-	mA
				-40°C	0.64	-	mA
Output Current (Sink)	IOL10	VDD = 10V, VOUT = 0.5V	1, 2	+85°C	0.9	-	mA
				-40°C	1.6	-	mA
Output Current (Sink)	IOL15	VDD = 15V, VOUT = 1.5V	1, 2	+85°C	2.4	-	mA
				-40°C	4.2	-	mA
Output Current (Source)	IOH5A	VDD = 5V, VOUT = 4.6V	1, 2	+85°C	-	-0.36	mA
				-40°C	-	-0.64	mA
Output Current (Source)	IOH5B	VDD = 5V, VOUT = 2.5V	1, 2	+85°C	-	-1.15	mA
				-40°C	-	-2.0	mA
Output Current (Source)	IOH10	VDD = 10V, VOUT = 9.5V	1, 2	+85°C	-	-0.9	mA
				-40°C	-	-1.6	mA
Output Current (Source)	IOH15	VDD = 15V, VOUT = 13.5V	1, 2	+85°C	-	-2.4	mA
				-40°C	-	-4.2	mA
Input Voltage Low	VIL	VDD=10V, VOH>9V, VOL<1V	1, 2	+25°C, +85°C, -40°C	-	3	V
Input Voltage High	VIH	VDD=10V, VOH>9V, VOL<1V	1, 2	+25°C, +85°C, -40°C	+7	-	V

ELECTRICAL PERFORMANCE CHARACTERISTICS (Continued)

PARAMETER	SYMBOL	CONDITIONS	NOTES	TEMPERATURE	LIMITS		UNITS
					MIN	MAX	
Propagation Delay Clock to Output	TPHL1 TPLH1	VDD = 10V VDD = 15V	1, 2, 3 1, 2, 3	+25°C +25°C	- -	230 160	ns ns
Propagation Delay Reset to Output	TPHL2	VDD = 10V VDD = 15V	1, 2, 3 1, 2, 3	+25°C +25°C	- -	225 170	ns ns
Transition Time	TTHL	VDD = 10V	1, 2, 3	+25°C	-	100	ns
	TTLH	VDD = 15V	1, 2, 3	+25°C	-	80	ns
Maximum Clock Input Frequency	FCL	VDD = 10V	1, 2, 3	+25°C	3	-	MHz
		VDD = 15V	1, 2, 3	+25°C	4	-	MHz
Maximum Clock Rise and Fall Time	TRCL TFCL	VDD = 5V	1, 2, 3, 4	+25°C	-	15	s
		VDD = 10V	1, 2, 3, 4	+25°C	-	5	s
		VDD = 15V	1, 2, 3, 4	+25°C	-	5	s
Minimum Enable Pulse Width	TW	VDD = 5V	1, 2, 3	+25°C	-	400	ns
		VDD = 10V	1, 2, 3	+25°C	-	200	ns
		VDD = 15V	1, 2, 3	+25°C	-	140	ns
Minimum Reset Pulse Width	TW	VDD = 5V	1, 2, 3	+25°C	-	250	ns
		VDD = 10V	1, 2, 3	+25°C	-	110	ns
		VDD = 15V	1, 2, 3	+25°C	-	80	ns
Minimum Clock Pulse Width	TW	VDD = 5V	1, 2, 3	+25°C	-	200	ns
		VDD = 10V	1, 2, 3	+25°C	-	100	ns
		VDD = 15V	1, 2, 3	+25°C	-	70	ns
Input Capacitance	CIN	Any Input	1, 2	+25°C	-	7.5	pF

NOTES:

1. All voltages referenced to device GND.
2. The parameters listed on Table 3 are controlled via design or process and are not directly tested. These parameters are characterized on initial design release and upon design changes which would affect these characteristics.
3. CL = 50pF, RL = 200K, Input TR, TF < 20ns.
4. If more than one unit is cascaded, TRCL should be made less than or equal to the sum of the transition time and the fixed propagation delay of the output of the driving stage for the estimated capacitive load.

Post Irradiation Electrical Performance Characteristics

PARAMETER	SYMBOL	CONDITIONS	NOTES	TEMPERATURE	LIMITS		UNITS
					MIN	MAX	
Supply Current	IDD	VDD = 20V, VIN = VDD or GND	1, 4	+25°C	-	25	μA
N Threshold Voltage	VNTH	VDD = 10V, ISS = -10μA	1, 4	+25°C	-2.8	-0.2	V
N Threshold Voltage Delta	ΔVTN	VDD = 10V, ISS = -10μA	1, 4	+25°C	-	1	V
P Threshold Voltage	VTP	VSS = 0V, IDD = 10μA	1, 4	+25°C	0.2	2.8	V
P Threshold Voltage Delta	ΔVTP	VSS = 0V, IDD = 10μA	1, 4	+25°C	-	1	V
Functional	F	VDD = 18V, VIN = VDD or GND	1	+25°C	VOH >	VOL <	V
		VDD = 3V, VIN = VDD or GND		+25°C	VDD/2	VDD/2	
Propagation Delay Time	TPHL TPLH	VDD = 5V	1, 2, 3, 4	+25°C	-	1.35 x +25°C Limit	ns

Logic Diagrams

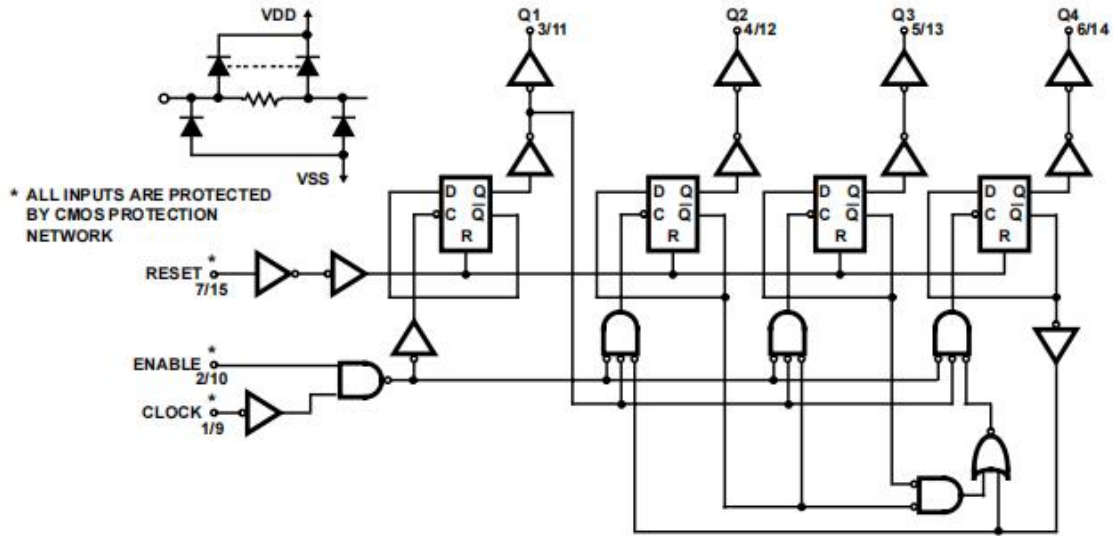

FIGURE 1. DECADE COUNTER (CD4518B) LOGIC DIAGRAM FOR ONE OF TWO IDENTICAL COUNTERS

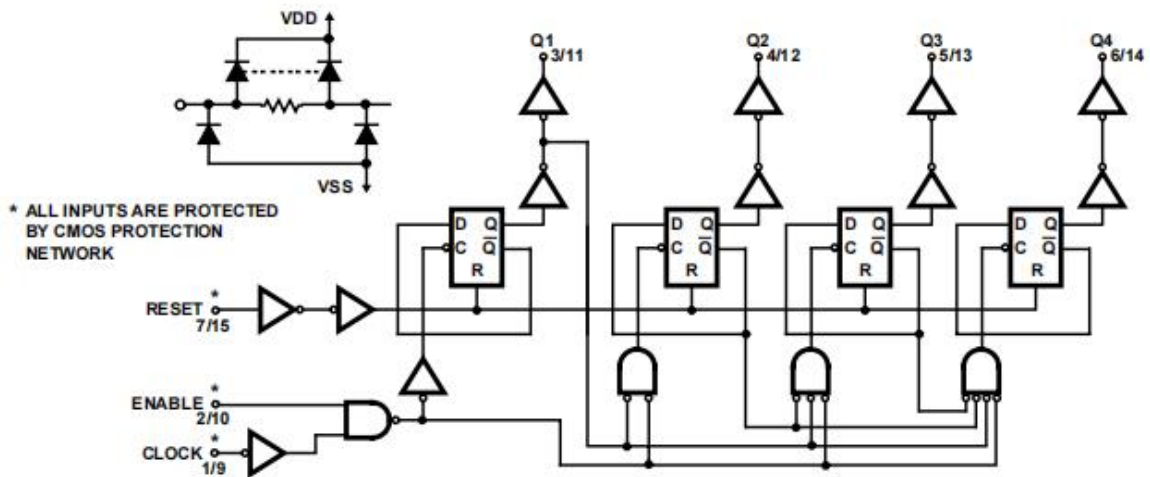

FIGURE 2. BINARY COUNTER (CD4520B) LOGIC DIAGRAM FOR ONE OF TWO IDENTICAL COUNTERS

TRUTH TABLE

CLOCK	ENABLE	RESET	ACTION
↗	1	0	Increment Counter
0	↘	0	Increment Counter
↘	X	0	No Change
X	↗	0	No Change
↗	0	0	No Change
1	↘	0	No Change
X	X	1	Q1 thru Q4 = 0

Typical Performance Curves

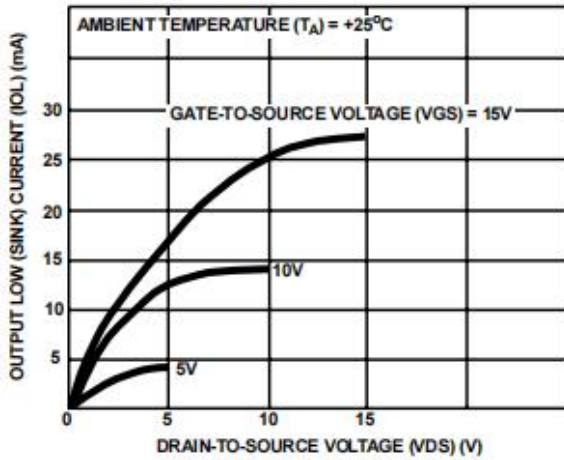

FIGURE 3. TYPICAL OUTPUT LOW (SINK) CURRENT CHARACTERISTICS

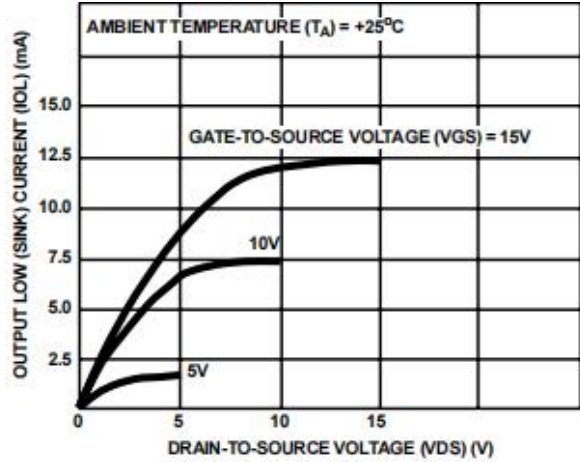

FIGURE 4. MINIMUM OUTPUT LOW (SINK) CURRENT CHARACTERISTICS

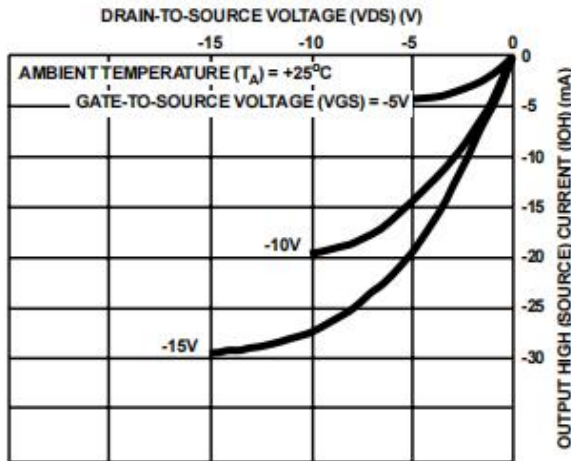

FIGURE 5. TYPICAL OUTPUT HIGH (SOURCE) CURRENT CHARACTERISTICS

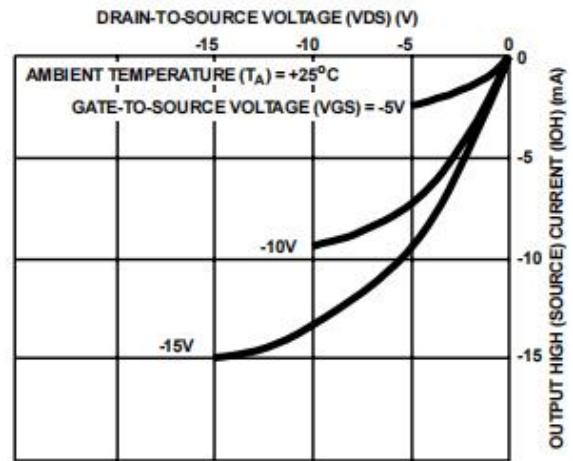

FIGURE 6. MINIMUM OUTPUT HIGH (SOURCE) CURRENT CHARACTERISTICS

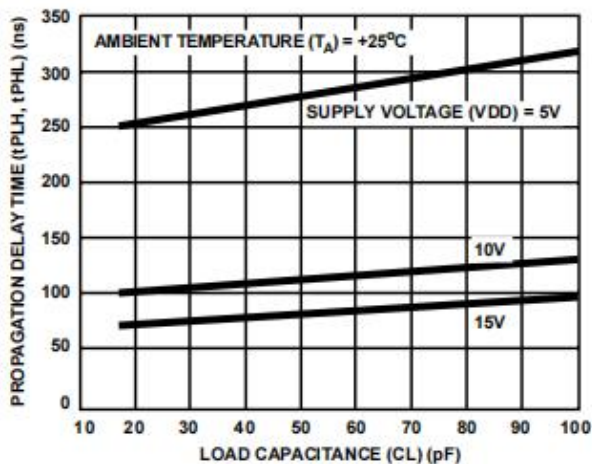

FIGURE 7. TYPICAL PROPAGATION DELAY vs LOAD CAPACITANCE, CLOCK OR ENABLE TO OUTPUT

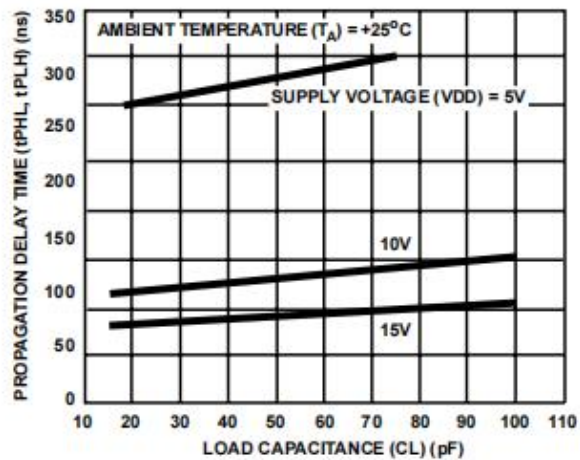

FIGURE 8. TYPICAL PROPAGATION DELAY TIME vs LOAD CAPACITANCE, RESET TO OUTPUT

Typical Performance Curves

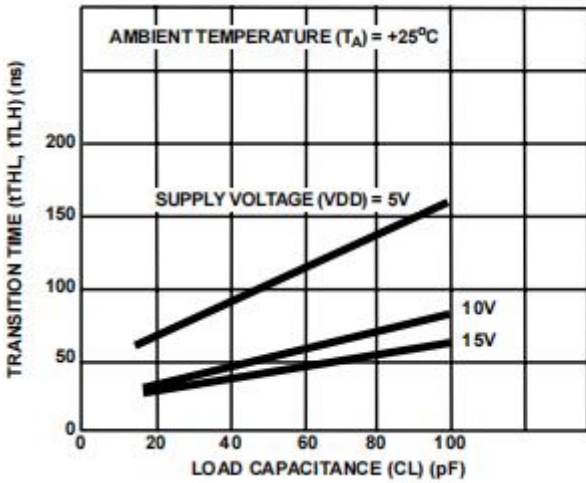

FIGURE 9. TYPICAL TRANSITION TIME vs LOAD CAPACITANCE

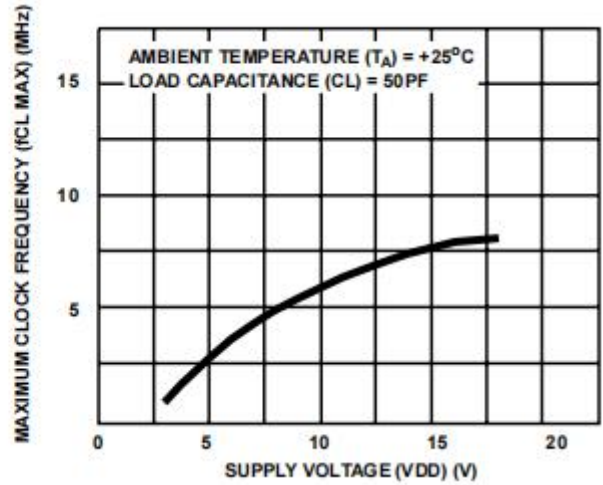

FIGURE 10. TYPICAL MAXIMUM CLOCK FREQUENCY vs SUPPLY VOLTAGE

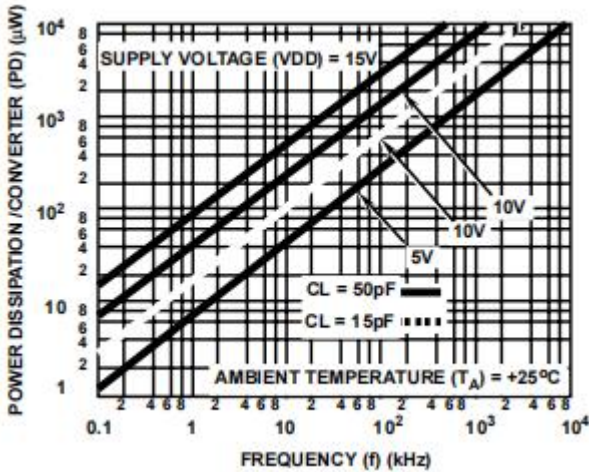

FIGURE 11. TYPICAL POWER DISSIPATION CHARACTERISTICS

Timing Diagrams

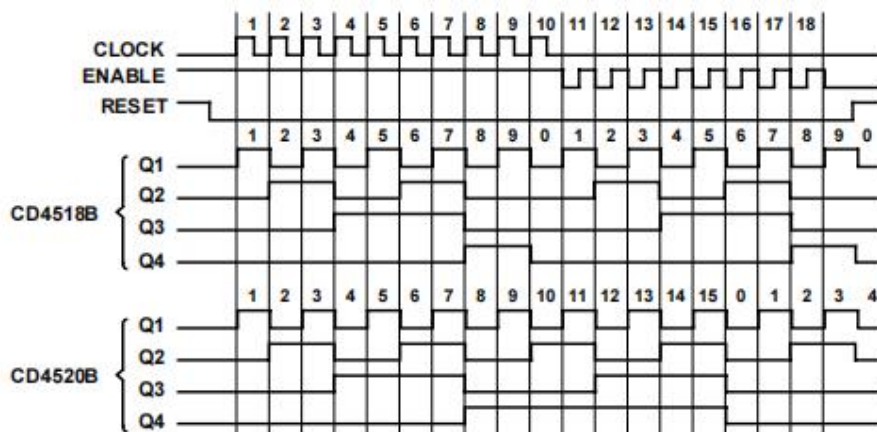

FIGURE 12. TIMING DIAGRAMS FOR CD4518B AND CD4520B

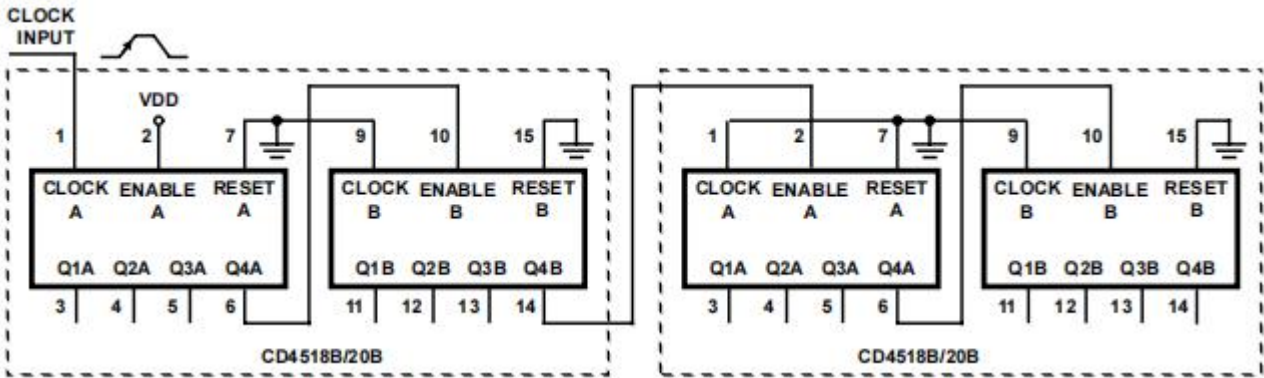
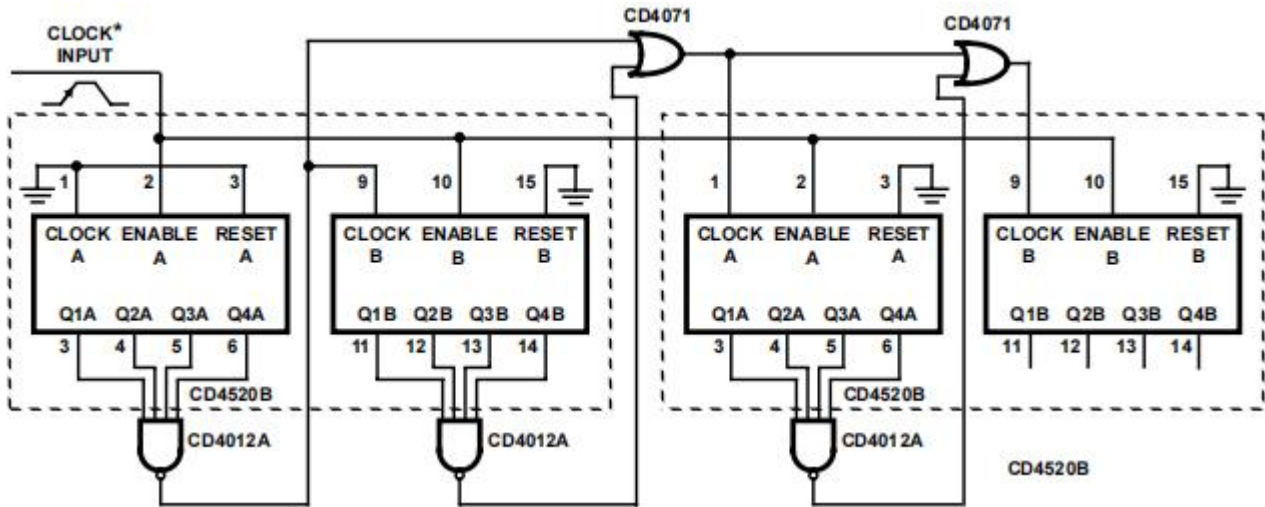
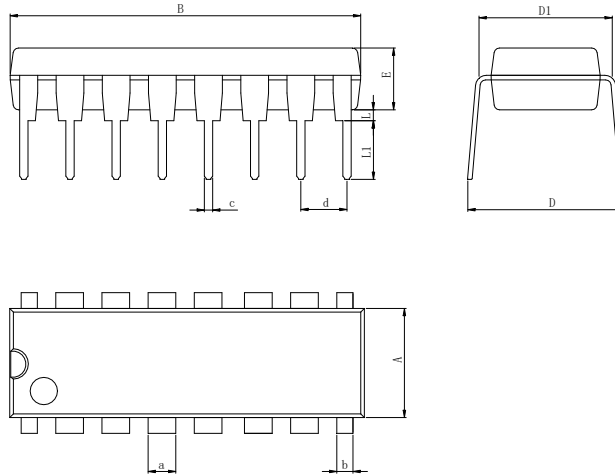

FIGURE 13. RIPPLE CASCADING OF FOUR COUNTERS WITH POSITIVE EDGE TRIGGERING



*For synchronous cascading, the clock transition time should be made less than or equal to the sum of the fixed propagation delay at 15pF and the transition time of the output driver stage for the estimated capacitive load.

FIGURE 14. SYNCHRONOUS CASCADING OF FOUR BINARY COUNTERS WITH NEGATIVE EDGE TRIGGERING

Physical Dimensions
DIP16

Dimensions In Millimeters(DIP16)											
Symbol:	A	B	D	D1	E	L	L1	a	b	c	d
Min:	6.10	18.94	8.40	7.42	3.10	0.50	300	1.50	0.85	0.40	2.54 BSC
Max:	6.68	19.56	9.00	7.82	3.55	0.70	3.60	1.55	0.90	0.50	

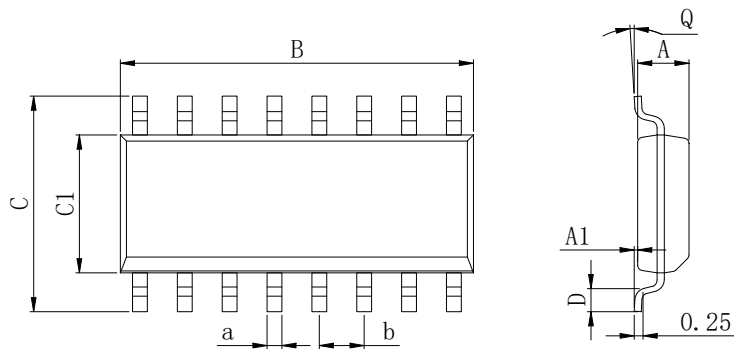
SOP16

Dimensions In Millimeters(SOP16)									
Symbol:	A	A1	B	C	C1	D	Q	a	b
Min:	1.35	0.05	9.80	5.80	3.80	0.40	0°	0.35	1.27 BSC
Max:	1.55	0.20	10.0	6.20	4.00	0.80	8°	0.45	

Physical Dimensions

TSSOP16

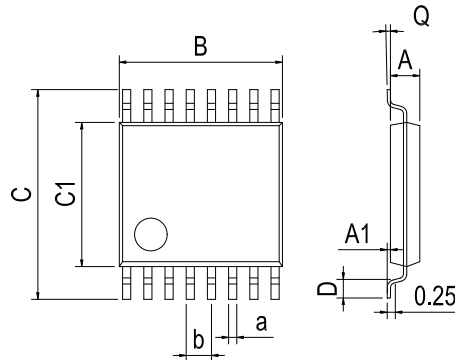

Dimensions In Millimeters(TSSOP16)									
Symbol:	A	A1	B	C	C1	D	Q	a	b
Min:	0.85	0.05	4.90	6.20	4.30	0.40	0°	0.20	0.65 BSC
Max:	0.95	0.20	5.10	6.60	4.50	0.80	8°	0.25	

IMPORTANT STATEMENT:

Huaguan Semiconductor reserves the right to change its products and services without notice. Before ordering, the customer shall obtain the latest relevant information and verify whether the information is up to date and complete. Huaguan Semiconductor does not assume any responsibility or obligation for the altered documents.

Customers are responsible for complying with safety standards and taking safety measures when using Huaguan Semiconductor products for system design and machine manufacturing. You will bear all the following responsibilities: select the appropriate Huaguan Semiconductor products for your application; Design, validate and test your application; Ensure that your application meets the appropriate standards and any other safety, security or other requirements. To avoid the occurrence of potential risks that may lead to personal injury or property loss.

Huaguan Semiconductor products have not been approved for applications in life support, military, aerospace and other fields, and Huaguan Semiconductor will not bear the consequences caused by the application of products in these fields.

The technical and reliability data (including data sheets), design resources (including reference designs), application or other design suggestions, network tools, safety information and other resources provided for the performance of semiconductor products produced by Huaguan Semiconductor are not guaranteed to be free from defects and no warranty, express or implied, is made. The use of testing and other quality control technologies is limited to the quality assurance scope of Huaguan Semiconductor. Not all parameters of each device need to be tested.

The documentation of Huaguan Semiconductor authorizes you to use these resources only for developing the application of the product described in this document. You have no right to use any other Huaguan Semiconductor intellectual property rights or any third party intellectual property rights. It is strictly forbidden to make other copies or displays of these resources. You should fully compensate Huaguan Semiconductor and its agents for any claims, damages, costs, losses and debts caused by the use of these resources. Huaguan Semiconductor accepts no liability for any loss or damage caused by infringement.

X-ON Electronics

Largest Supplier of Electrical and Electronic Components

Click to view similar products for [Counter ICs](#) category:

Click to view products by [HGSEMI](#) manufacturer:

Other Similar products are found below :

[CD4018BE](#) [CD4033BE](#) [CD4060BE](#) [CD4040BE](#) [NLV14040BDR2G](#) [RFDIP1607ALM9T21](#) [RFDIP1606L708D1T](#) [RFTIP2510T12A8Q1C](#)
[74HC161DT](#) [CD4028BM/TR](#) [CD4060DM/TR](#) [CD4022BE](#) [CD4060DMT/TR](#) [CD4020BE](#) [CD4060BMT/TR](#) [74HC192M/TR](#)
[CD4020BMT/TR](#) [CD4017CMT/TR](#) [74HC193M/TR](#) [CD4017CM/TR](#) [AiP74HC193SA16.TB](#) [CD4518BM/TR](#) [CD4060TA16.TB](#) [CD4060DE](#)
[CD4017CN](#) [CD4017BMT/TR](#) [U74HC4060G-S16-R](#) [CD4017SA.TB](#) [XD74LS160](#) [CD4017BM-MS](#) [CD4022BM/TR](#) [CD4022BMT/TR](#)
[CD4028BDRG](#) [CD4060BDRG](#) [CD4017DA.TB](#) [CD4520BDRG](#) [CD4520BM\(LX\)](#) [CD4518BM\(LX\)](#) [SN74HC393DR\(LX\)](#) [SN74HC393N\(LX\)](#)
[CD4060BM\(LX\)](#) [CD4060BE\(LX\)](#) [CD4518BE\(LX\)](#) [CD4520BE\(LX\)](#) [74VHC393FT\(BJ\)](#) [74VHC161FT\(BJ\)](#) [74VHC163FT\(BJ\)](#)
[74HC4040D.653](#) [74HC4060D.653](#) [74HCT4040D.653](#)