

## Dual Precision Monostable

### General Description

The CD4538B is a dual, precision monostable multivibrator with independent trigger and reset controls. The device is retriggerable and resettable, and the control inputs are internally latched. Two trigger inputs are provided to allow either rising or falling edge triggering. The reset inputs are active low and prevent triggering while active. Precise control of output pulse-width has been achieved using linear CMOS techniques. The pulse duration and accuracy are determined by external components RX and CX. The device does not allow the timing capacitor to discharge through the timing pin on power-down condition. For this reason, no external protection resistor is required in series with the timing pin. Input protection from static discharge is provided on all pins.

### Features

- Wide supply voltage range: 5.0V to 15V
- High noise immunity: 0.45 V<sub>CC</sub> (typ.)
- Low power TTL compatibility: Fan out of 2 driving 74L or 1 driving 74LS
- New formula:  $PW_{OUT} = RC$  (PW in seconds, R in Ohms, C in Farads)
- ±1.0% pulse-width variation from part to part (typ.)
- Wide pulse-width range: 1 μS to ∞
- Separate latched reset inputs
- Symmetrical output sink and source capability
- Low standby current: 5 nA (typ.) @ 5 V<sub>DC</sub>
- Pin compatible to CD4528B

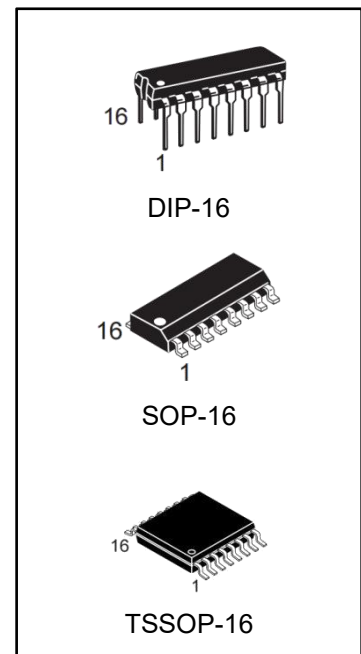

### Ordering Information

DEVICE	Package Type	MARKING	Packing	Packing Qty
CD4538BE	DIP-16	CD4538B	TUBE	1000pcs/box
CD4538BM/TR	SOP-16	CD4538B	REEL	2500pcs/reel
CD4538BMT/TR	TSSOP-16	CD4538B	REEL	2500pcs/reel

## Block and Connection Diagrams

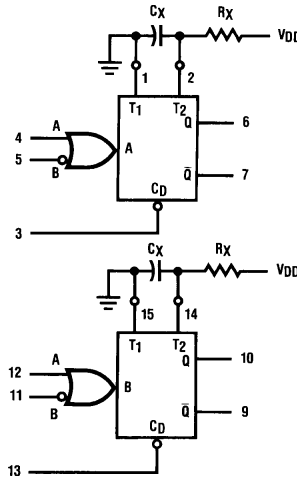

RX and CX are External Components

$V_{DD}$ —Pin 16

$V_{SS}$ —Pin 8

## Dual-In-Line Package

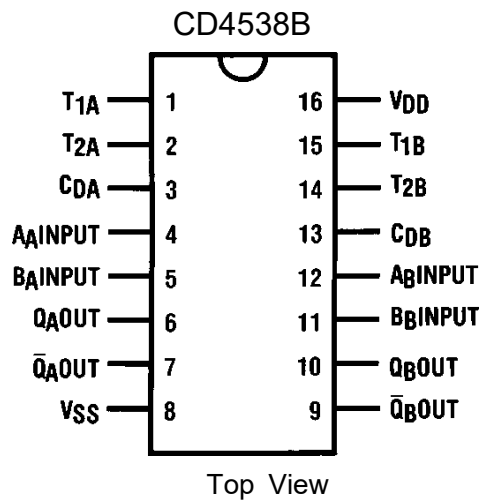

## Truth Table

Inputs			Outputs	
Clear	A	B	Q	Q
L	X	X	L	H
X	H	X	L	H
X	X	L	L	H
H	L	↓	M	W
H	↑	H	M	W

H= High Level L

L= Low Level

↑= Transition from Low to High

↓= Transition from High to Low

M= One High Level Pulse

W= One Low Level Pulse

X= Irrelevant

## Maximum Ratings

Symbol	Parameter	Min	Max	Unit	
VDD	DC Supply Voltage	-0.5	+18	V <sub>DC</sub>	
V <sub>IN</sub>	Input Voltage	-0.5	0.5	V <sub>DC</sub>	
T <sub>S</sub>	Storage Temperature Range	-65	+150	°C	
P <sub>D</sub>	Power Dissipation	Dual-In-Line	700	mW	
		Small Outline	500	mW	
T <sub>L</sub>	Lead Temperature	Soldering, 10 seconds		260	°C

Note 1: "Absolute Maximum Ratings" are those values beyond which the safety of the device cannot be guaranteed, they are not meant to imply that the devices should be operated at these limits. The tables of "Recommended Operating Conditions" and "Electrical Characteristics" provide conditions for actual device operation.

Note 2: VSS e 0V unless otherwise specified.

## Recommended Operating Conditions

Symbol	Parameter	Min	Max	Unit
VDD	DC Supply Voltage	5	15	V <sub>DC</sub>
V <sub>IN</sub>	Input Voltage	0	-	V <sub>DC</sub>
T <sub>A</sub>	Operating Temperature Range	-40	+85	°C

## DC Electrical Characteristics

Symbol	Parameter	Conditions	-40°C		+25°C			+85°C		Units	
			Min	Max	Min	Typ	Max	Min	Max		
IDD	Quiescent Device Current	VDD=5V } VIH=VDD		20		0.005	20		150	μA	
		VDD=10V } VIL=VSS		40		0.010	40		300		
		VDD=15V } All Outputs Open		80		0.015	80		600		
VOL	Low Level Output Voltage	VDD=5V } I <sub>OL</sub> <1 μA		0.05		0	0.05		0.05	V	
		VDD=10V } VIH=VDD, VIL=VSS		0.05		0	0.05		0.05		
		VDD=15V }		0.05		0	0.05		0.05		
VOH	High Level Output Voltage	VDD=5V } I <sub>OL</sub> <1 μA	4.95		4.95	5		4.95		V	
		VDD=10V } VIH=VDD, VIL=VSS	9.95		9.95	10		9.95			
		VDD=15V }	14.95		14.95	15		14.95			
VIL	Low Level Input Voltage	I <sub>OL</sub> <1 μA		1.5		2.25	1.5		1.5	V	
		VDD=5V, VO=0.5V of 4.5V		3.0		4.50	3.0		3.0		
		VDD=10V, VO=1.0V of 9.0V		4.0		6.75	4.0		4.0		
VIH	High Level Input Voltage	I <sub>OL</sub> <1 μA	3.5		3.5	2.75		3.5		V	
		VDD=5V, VO=0.5V of 4.5V	7.0		7.0	5.50		7.0			
		VDD=10V, VO=1.0V of 9.0V	11.0		11.0	8.25		11.0			
IOL	Low Level Output Current (Note 3)	VDD=5V, VO=0.4V } VIH=VDD	0.52		0.44	0.88		0.36		mA	
		VDD=10V, VO=0.5V } VIL=VSS	1.3		1.1	2.25		0.9			
		VDD=15V, VO=1.5V }	3.6		3.0	8.8		2.4			
IOH	High Level Output Current (Note 3)	VDD=5V, VO=4.6 } VIL=VSS	-0.52		-0.44	-0.88		-0.36		mA	
		VDD=10V, VO=9.5V }	-1.3		-1.1	-2.25		-0.9			
		VDD=15V, VO=13.5V }	-3.6		-3.0	-8.8		-2.4			
IIN	Input Current, Pin2 or 14	VDD=15V, VIN=0V or 15V			±0.02		±10 <sup>-5</sup>	±0.05		±0.5	μA
IIN	Input Current Other Inputs	VDD=15V, VIN=0V or 15V			±0.3		±10 <sup>-5</sup>	±0.3		±1.0	μA

Note 3: IOH and IOL are tested one output at a time.

## AC Electrical Characteristics

\* TA = 25°C, CL = 50 pF, and tr = tf = 20 ns unless otherwise specified

Symbol	Parameter	Conditions	Min	Typ	Max	Units
tTLH, tTHL	Output Transition Time	V <sub>DD</sub> =5V V <sub>DD</sub> =10V V <sub>DD</sub> =15V		100 50 40	200 100 80	ns
tPLH, tPHL	Propagation Delay Time	Trigger Operation— A or B to Q or Q̄ V <sub>DD</sub> =5V V <sub>DD</sub> =10V V <sub>DD</sub> =15V		300 150 100	600 300 220	ns
		Reset Operation— C <sub>D</sub> to Q or Q̄ V <sub>DD</sub> =5V V <sub>DD</sub> =10V V <sub>DD</sub> =15V		250 125 95	500 250 190	ns
tWL, tWH	Minimum Input Pulse Width A, B, or C <sub>D</sub>	V <sub>DD</sub> =5V V <sub>DD</sub> =10V V <sub>DD</sub> =15V		35 30 25	70 60 50	ns
tRR	Minimum Retrigger Time	V <sub>DD</sub> =5V V <sub>DD</sub> =10V V <sub>DD</sub> =15V		0	0 0 0	ns
C <sub>IN</sub>	Input Capacitance	Pin 2 or 14 Other Inputs		10 5	7.5	pF
PW <sub>OUT</sub>	Output Pulse Width (Q or Q̄) (Note: For Typical Distribution, see Figure 9)	R <sub>X</sub> =100 kΩ V <sub>DD</sub> =5V V <sub>DD</sub> =10V V <sub>DD</sub> =15V	208 211 216	226 230 235	244 248 254	μS
		R <sub>X</sub> =100 kΩ C <sub>X</sub> =0.1 μF V <sub>DD</sub> =5V V <sub>DD</sub> =10V V <sub>DD</sub> =15V	8.83 9.02 9.20	9.60 9.80 10.00	10.37 10.59 10.80	ms
		R <sub>X</sub> =100kΩ C <sub>X</sub> =10.0 μF V <sub>DD</sub> =5V V <sub>DD</sub> =10V V <sub>DD</sub> =15V	0.87 0.89 0.91	0.95 0.97 0.99	1.03 1.05 1.07	S
Pulse Width Match between Circuits in the Same Package C <sub>X</sub> =0.1 μF, R <sub>X</sub> =100 kΩ		R <sub>X</sub> =100 kΩ C <sub>X</sub> =0.1 μF V <sub>DD</sub> =5V V <sub>DD</sub> =10V V <sub>DD</sub> =15V		±1 ±1 ±1		%
Operating Conditions						
R <sub>X</sub>	External Timing Resistance		5.0		**	kΩ
C <sub>X</sub>	External Timing Capacitance		0		No Limit	pF

Note 4: AC parameters are guaranteed by DC correlated testing.

Note 5: The maximum usable resistance R<sub>X</sub> is a function of the leakage of the Capacitor C<sub>X</sub>, leakage of the CD4538B, and leakage due to board layout, surface resistance, etc.

## Logic Diagram

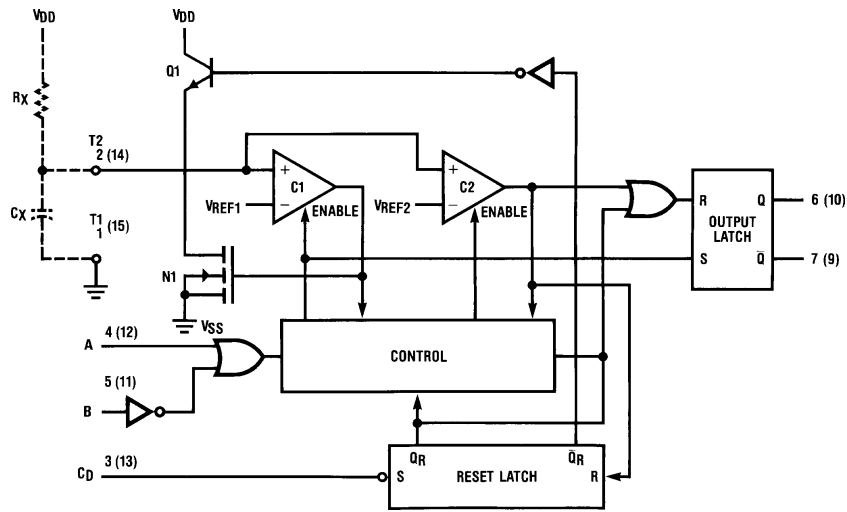

FIGURE 1

## Theory of Operation

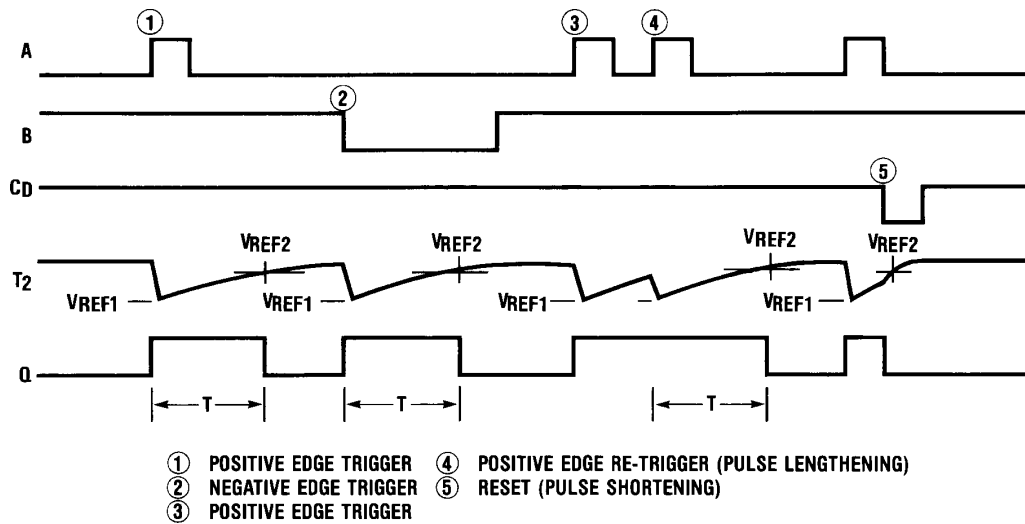

FIGURE 2

## Trigger Operation

The block diagram of the CD4538B is shown in Figure 1, with circuit operation following.

As shown in Figures 1 and 2, before an input trigger occurs, the monostable is in the quiescent state with the Q output low, and the timing capacitor  $C_X$  completely charged to  $V_{DD}$ . When the trigger input A goes from  $V_{SS}$  to  $V_{DD}$  (while inputs B and  $C_D$  are held to  $V_{DD}$ ) a valid trigger is recognized, which turns on comparator C1 and N-Channel transistor N1<sup>①</sup>. At the same time the output latch is set. With transistor N1 on, the capacitor  $C_X$  rapidly discharges toward  $V_{SS}$  until  $V_{REF1}$  is reached. At this point the output of comparator C1 changes state and transistor N1 turns off. Comparator C1 then turns off while at the same time comparator C2 turns on. With transistor N1 off, the capacitor  $C_X$  begins to charge through the timing resistor,  $R_X$ , toward  $V_{DD}$ . When the voltage across  $C_X$  equals  $V_{REF2}$ , comparator C2 changes state causing the output latch to reset (Q goes low) while at the same time disabling comparator C2. This ends the timing cycle with the monostable in the quiescent state, waiting for the next trigger.

A valid trigger is also recognized when trigger input B goes from  $V_{DD}$  to  $V_{SS}$  (while input A is at  $V_{SS}$  and input  $C_D$  is at  $V_{DD}$ )<sup>②</sup>.

It should be noted that in the quiescent state  $C_X$  is fully charged to  $V_{DD}$ , causing the current through resistor  $R_X$  to be zero. Both comparators are "off" with the total device current due only to reverse junction leakages. An added feature of the CD4538B is that the output latch is set via the input trigger without regard to the capacitor voltage. Thus, propagation delay from trigger to Q is independent of the value of  $C_X$ ,  $R_X$ , or the duty cycle of the input waveform.

## Retrigger Operation

The CD4538B is retriggered if a valid trigger occurs<sup>③</sup> followed by another valid trigger<sup>④</sup> before the Q output has returned to the quiescent (zero) state. Any retrigger, after the timing node voltage at pin 2 or 14 has begun to rise from  $V_{REF1}$ , but has not yet reached  $V_{REF2}$ , will cause an increase in output pulse width T. When a valid retrigger is initiated<sup>④</sup>, the voltage at T2 will again drop to  $V_{REF1}$  before progressing along the RC charging curve toward  $V_{DD}$ . The Q output will remain high until time T, after the last valid retrigger.

## Reset Operation

The CD4538B may be reset during the generation of the output pulse. In the reset mode of operation, an input pulse on  $C_D$  sets the reset latch and causes the capacitor to be fast charged to  $V_{DD}$  by turning on transistor Q1<sup>⑤</sup>. When the voltage on the capacitor reaches  $V_{REF2}$ , the reset latch will clear and then be ready to accept another pulse. If the  $C_D$  input is held low, any trigger inputs that occur will be inhibited and the Q and  $\bar{Q}$  outputs of the output latch will not change. Since the Q output is reset when an input low level is detected on the  $C_D$  input, the output pulse T can be made significantly shorter than the minimum pulse width specification

Typical Applications

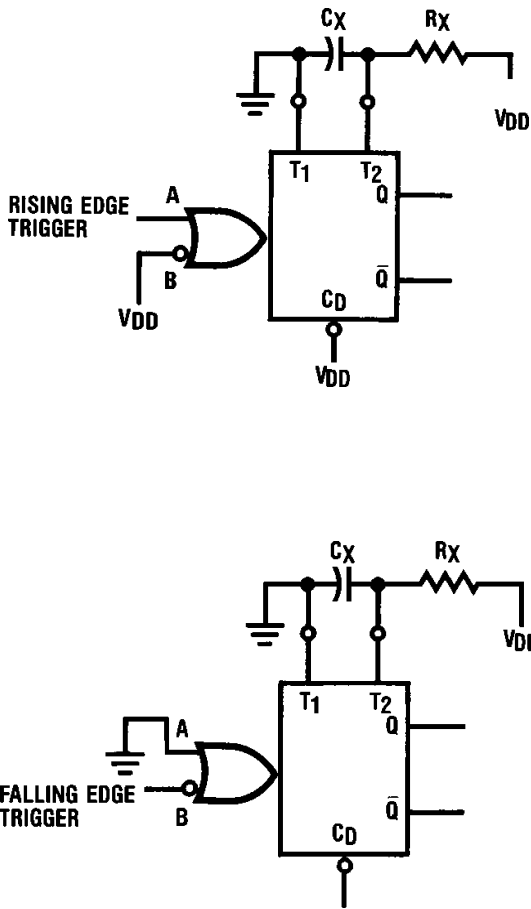

FIGURE 3. Retriggerable Monostables Circuitry

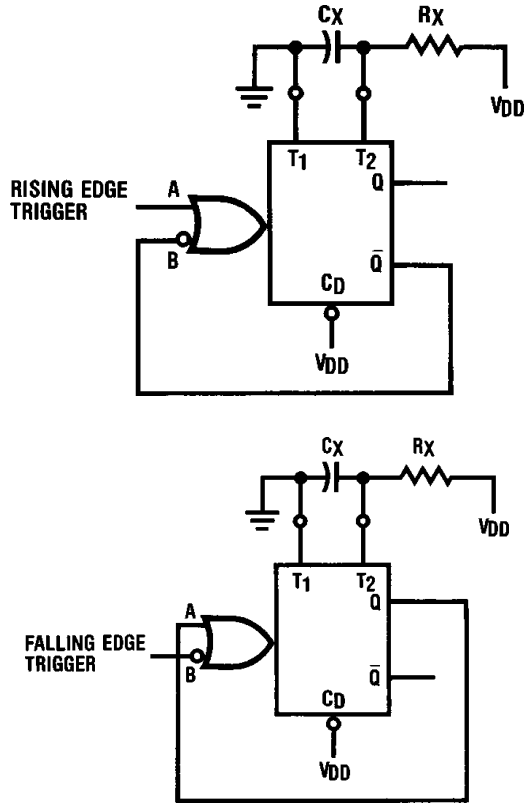

FIGURE 4. Non-Retriggerable Monostables Circuitry

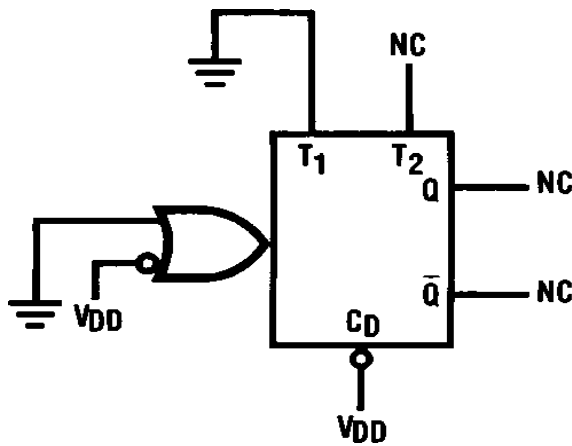

FIGURE 5. Connection of Unused Sections

## Typical Applications

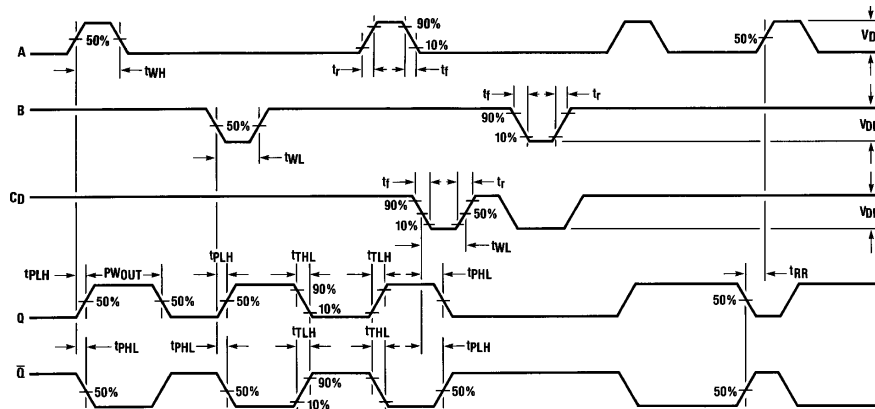
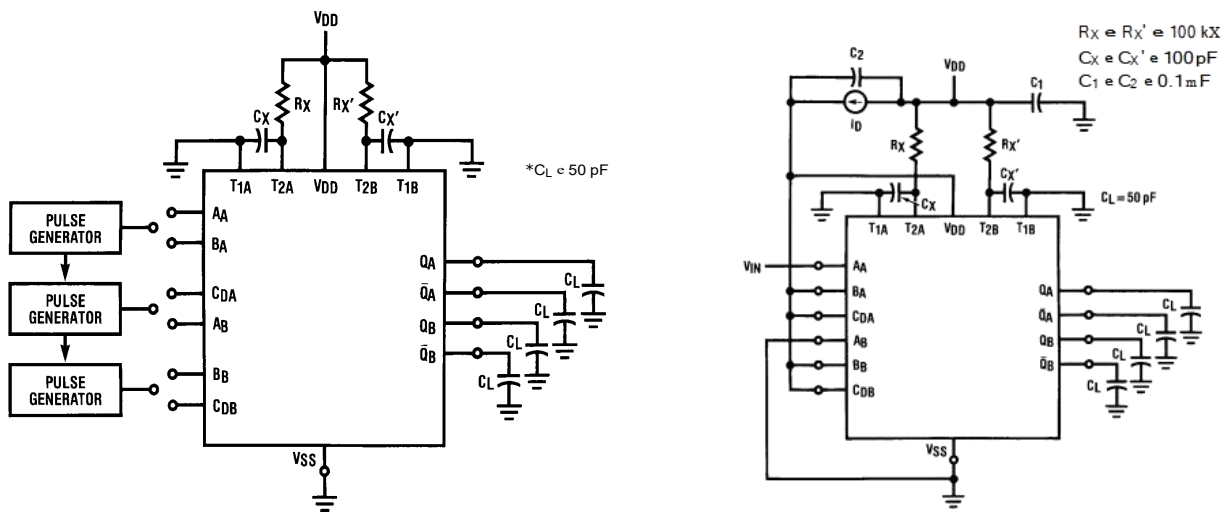

FIGURE 6. Switching Test Waveforms



### Input Connections

Characteristics	CD	A	B
$t_{PLH}$ , $t_{PHL}$ , $t_{TLH}$ , $t_{THL}$ $PW_{OUT}$ , $t_{WH}$ , $t_{WL}$	VDD	PG1	VDD
$t_{PLH}$ , $t_{PHL}$ , $t_{TLH}$ , $t_{THL}$ $PW_{OUT}$ , $t_{WH}$ , $t_{WL}$	VDD	VSS	PG2
$t_{PLH(R)}$ , $t_{PHL(R)}$ , $t_{WH}$ , $t_{WL}$	PG3	PG1	PG2

\*Includes capacitance of probes, wiring, and fixture parasitic  
Note: Switching test waveforms for PG1, PG2, PG3 are shown in Figure 6.

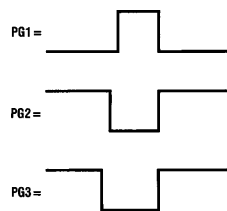

FIGURE 7. Switching Test Circuit

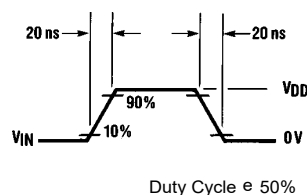

FIGURE 8. Power Dissipation Test Circuit and Waveforms



Typical Applications

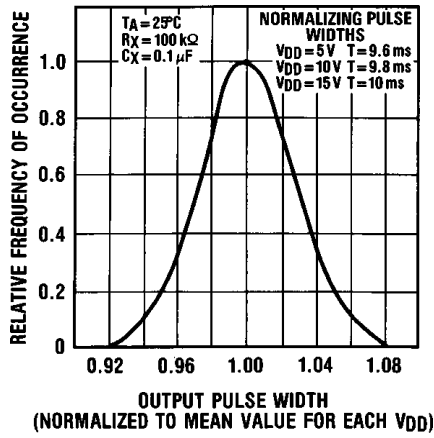

FIGURE 9. Typical Normalized Distribution of Units for Output Pulse Width

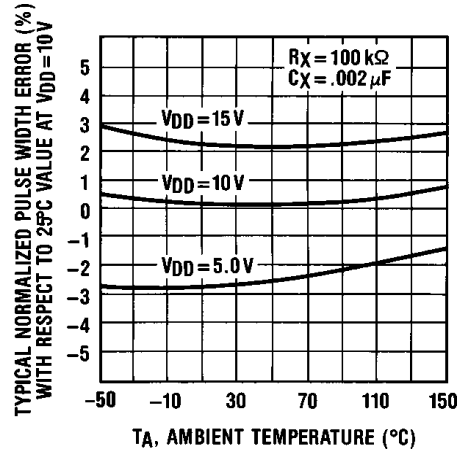

FIGURE 12. Typical Pulse Width Error Versus Temperature

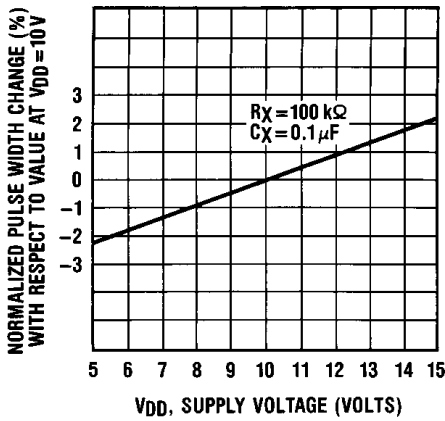

FIGURE 10. Typical Pulse Width Variation as a Function of Supply Voltage  $V_{DD}$

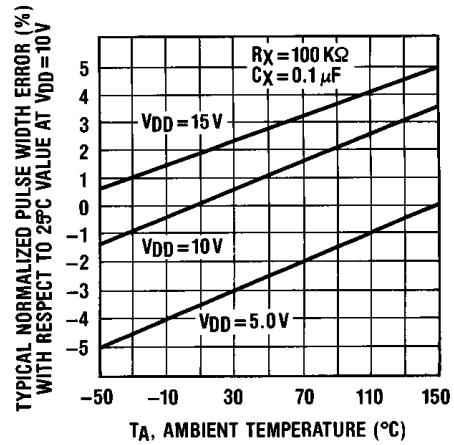

FIGURE 13. Typical Pulse Width Error Versus Temperature

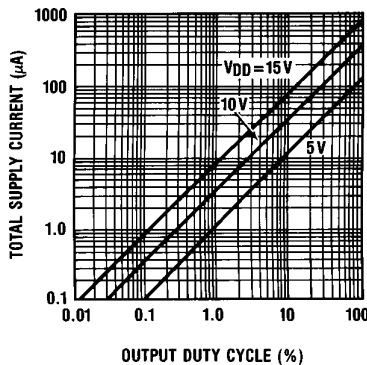

FIGURE 11. Typical Total Supply Current Versus Output Duty Cycle,  $R_X = 100\text{ k}\Omega$ ,  $C_L = 50\text{ pF}$ ,  $C_X = 100\text{ pF}$ , One Monostable Switching Only

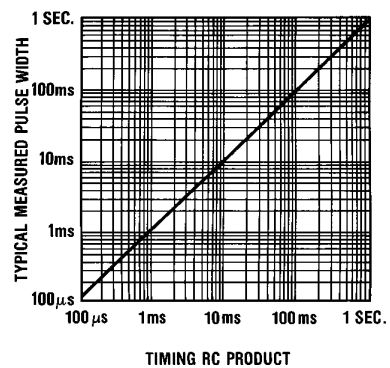
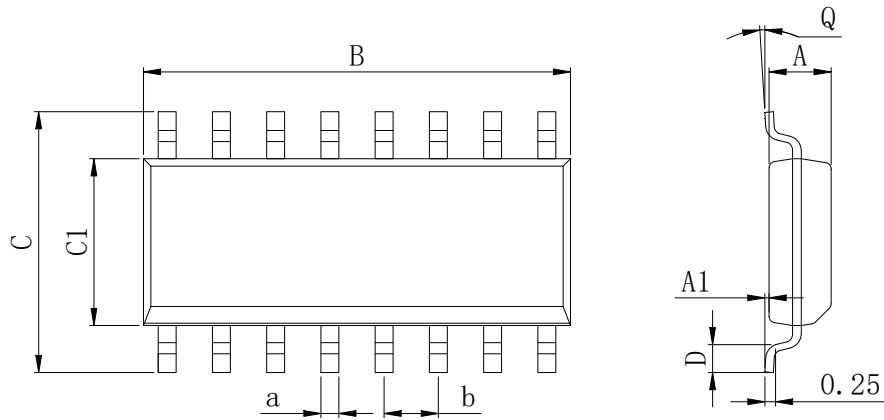

FIGURE 14. Typical Pulse Width Versus Timing RC Product

## Physical Dimensions

SOP16



Dimensions In Millimeters(SOP16)									
Symbol:	A	A1	B	C	C1	D	Q	a	b
Min:	1.35	0.05	9.80	5.80	3.80	0.40	0°	0.35	1.27 BSC
Max:	1.55	0.20	10.0	6.20	4.00	0.80	8°	0.45	

DIP16

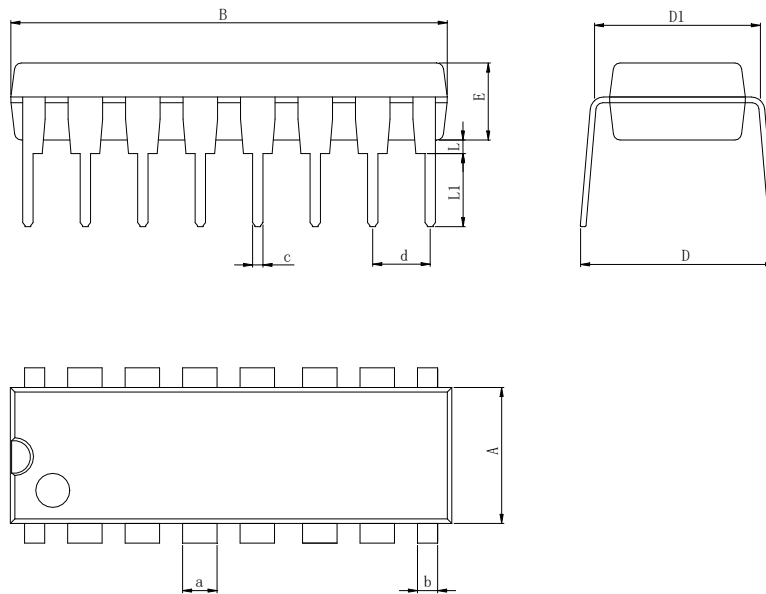

Dimensions In Millimeters(DIP16)											
Symbol:	A	B	D	D1	E	L	L1	a	b	c	d
Min:	6.10	18.94	8.40	7.42	3.10	0.50	3.00	1.50	0.85	0.40	2.54 BSC
Max:	6.68	19.56	9.00	7.82	3.55	0.70	3.60	1.55	0.90	0.50	

**Physical Dimensions**

TSSOP16

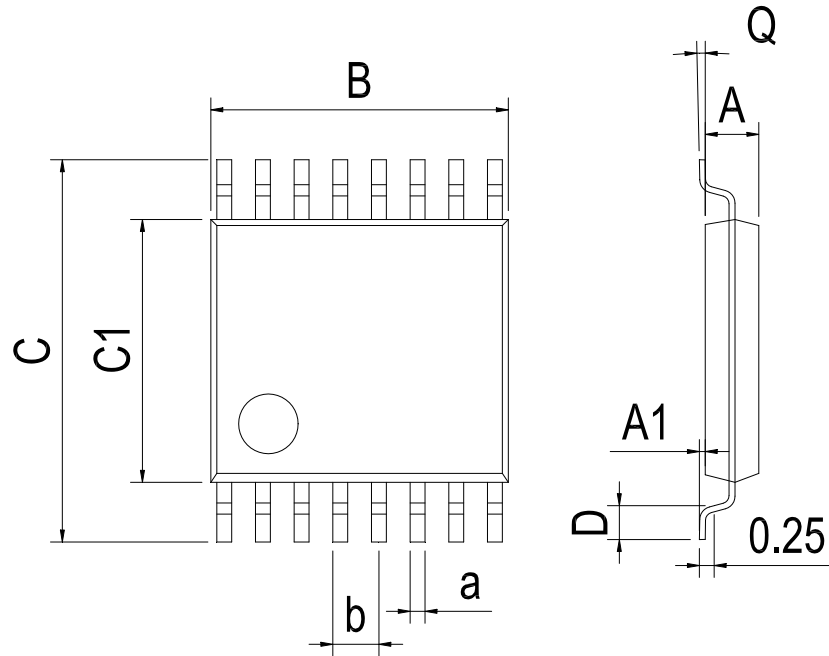

Dimensions In Millimeters(TSSOP16)									
Symbol:	A	A1	B	C	C1	D	Q	a	b
Min:	0.85	0.05	4.90	6.20	4.30	0.40	0°	0.20	0.65 BSC
Max:	0.95	0.20	5.10	6.60	4.50	0.80	8°	0.25	

**IMPORTANT STATEMENT:**

Huaguan Semiconductor reserves the right to change its products and services without notice. Before ordering, the customer shall obtain the latest relevant information and verify whether the information is up to date and complete. Huaguan Semiconductor does not assume any responsibility or obligation for the altered documents.

Customers are responsible for complying with safety standards and taking safety measures when using Huaguan Semiconductor products for system design and machine manufacturing. You will bear all the following responsibilities: Select the appropriate Huaguan Semiconductor products for your application; Design, validate and test your application; Ensure that your application meets the appropriate standards and any other safety, security or other requirements. To avoid the occurrence of potential risks that may lead to personal injury or property loss.

Huaguan Semiconductor products have not been approved for applications in life support, military, aerospace and other fields, and Huaguan Semiconductor will not bear the consequences caused by the application of products in these fields. All problems, responsibilities and losses arising from the user's use beyond the applicable area of the product shall be borne by the user and have nothing to do with Huaguan Semiconductor, and the user shall not claim any compensation liability against Huaguan Semiconductor by the terms of this Agreement.

The technical and reliability data (including data sheets), design resources (including reference designs), application or other design suggestions, network tools, safety information and other resources provided for the performance of semiconductor products produced by Huaguan Semiconductor are not guaranteed to be free from defects and no warranty, express or implied, is made. The use of testing and other quality control technologies is limited to the quality assurance scope of Huaguan Semiconductor. Not all parameters of each device need to be tested.

The documentation of Huaguan Semiconductor authorizes you to use these resources only for developing the application of the product described in this document. You have no right to use any other Huaguan Semiconductor intellectual property rights or any third party intellectual property rights. It is strictly forbidden to make other copies or displays of these resources. You should fully compensate Huaguan Semiconductor and its agents for any claims, damages, costs, losses and debts caused by the use of these resources. Huaguan Semiconductor accepts no liability for any loss or damage caused by infringement.

## X-ON Electronics

Largest Supplier of Electrical and Electronic Components

*Click to view similar products for [Flip-Flops](#) category:*

*Click to view products by [HGSEMI](#) manufacturer:*

Other Similar products are found below :

[74F574SC](#) [TC7W74FUTE12LF](#) [NLV74HC74ADR2G](#) [MC10EP131MNG](#) [MC74AC74DTR2](#) [CD4013BMT/TR](#) [74VHC574FT\(BJ\)](#)  
[U74AHC14G-P14-R](#) [U74HC14G-S14-R](#) [CD40106BE](#) [HT4093ARZ](#) [74LVC1G80GW-Q100,1](#) [CD4013](#) [U74HC74G-P14-R](#)  
[AIP74HC574SA20.TR](#) [74HC123MT/TR](#) [74HC374M/TR](#) [74HC123M/TR](#) [CD40106DMT/TR](#) [CD40106DE](#) [CD4538BMT/TR](#)  
[MC74HC73ADG](#) [MC74HC73ADR2G](#) [74LCX16374MTDX](#) [74LVT74D,118](#) [74VHCT9273FT\(BJ\)](#) [JM38510/37202BEA](#) [MM74HC374WM](#)  
[74ALVCH162374PAG](#) [74LVC1G175GS,132](#) [74LVX74MTCX](#) [TC7WZ74FK,LJ\(CT](#) [JM38510/30106BEA](#) [JM38510/00204BEA](#)  
[MM74HCT273WM](#) [SN74LVC74AD](#) [MC74HC73ADTR2G](#) [SN74HC273DWR](#) [M74HC374RM13TR](#) [M74HC175B1R](#) [M74HC174RM13TR](#)  
[74ALVTH32374ZKER](#) [74AUP1G74DC,125](#) [74VHC374FT\(BJ\)](#) [74VHCV374FT\(BJ\)](#) [74VHCV574FT\(BJ\)](#) [SN74LVC74ADR](#)  
[SN74HC574PWR](#) [SN74HC374AN](#) [SN74AS574DWR](#)