

3-Pin Microprocessor Reset Monitors

The HG809 and HG810 are cost-effective system supervisor circuits designed to monitor V_{CC} in digital systems and provide a reset signal to the host processor when necessary. No external components are required.

The reset output is driven active within 20 μ sec of V_{CC} falling through the reset voltage threshold. Reset is maintained active for a minimum of 140msec after V_{CC} rises above the reset threshold. The

HG810 has an active-high $\overline{\text{RESET}}$ output while the HG809 has an active-low $\overline{\text{RESET}}$ output. The output of the HG809 is guaranteed valid down to $V_{CC} = 1\text{V}$. Both devices are available in a SOT-23 package.

The HG809/810 are optimized to reject fast transient glitches on the V_{CC} line. Low supply current of 17 μA ($V_{CC} = 3.3\text{V}$) makes these devices suitable for battery powered applications.

Features

- Precision V_{CC} Monitor for 3.0V, 3.3V, and 5.0V Supplies
- 140msec Guaranteed Minimum $\overline{\text{RESET}}$, $\overline{\text{RESET}}$ Output Duration
- $\overline{\text{RESET}}$ Output Guaranteed to $V_{CC} = 1.0\text{V}$ (HG809)
- Low 17 μA Supply Current
- V_{CC} Transient Immunity
- Small SOT-23 Package
- No External Components
- Wide Operating Temperature: -40°C to 85°C

Typical Applications

- Computers
- Embedded Systems
- Battery Powered Equipment
- Critical μP Power Supply Monitoring

TYPICAL APPLICATION DIAGRAM

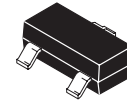
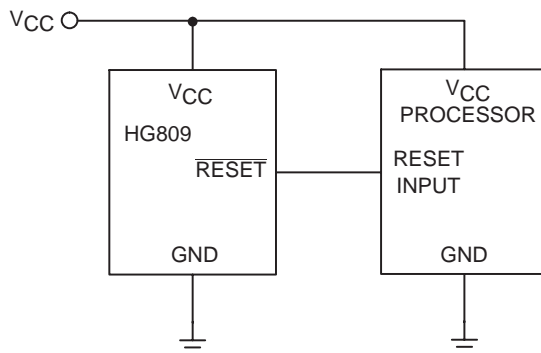

**SOT-23
(TO-236)
CASE 318**

PIN CONFIGURATION

(Top View)

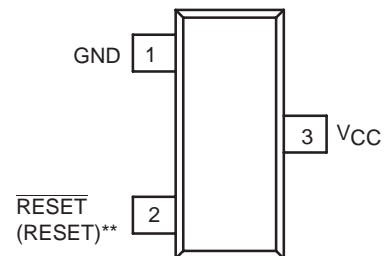

SOT-23*

NOTE: *SOT-23 is equivalent to JEDEC (TO-236)

** $\overline{\text{RESET}}$ is for HG809

** $\overline{\text{RESET}}$ is for HG810

NOTE: The "x" denotes a suffix for V_{CC} threshold – see table below

Suffix	Reset V_{CC} Threshold (V)
L	4.63
M	4.38
J*	4.00
T	3.08
S	2.93
R	2.63

NOTE: *J version is available for HG809 only

ABSOLUTE MAXIMUM RATINGS*

Symbol	Parameter	Value	Unit
	Supply Voltage (V_{CC} to GND)	6.0	V
	\overline{RESET} , RESET	-0.3 to ($V_{CC} + 0.3$)	V
	Input Current, V_{CC}	20	mA
	Output Current, \overline{RESET} , RESET	20	mA
	dV/dt (V_{CC})	100	V/ μ sec
P_D	Power Dissipation ($T_A \leq 70^\circ\text{C}$) SOT-23 (derate 4mW/ $^\circ\text{C}$ above $+70^\circ\text{C}$)	230	mW
T_A	Operating Temperature Range	-40 to +85	$^\circ\text{C}$
T_{stg}	Storage Temperature Range	-65 to +150	$^\circ\text{C}$
T_{sol}	Lead Temperature (Soldering, 10 Seconds)	+260	$^\circ\text{C}$

* Maximum Ratings are those values beyond which damage to the device may occur.

ELECTRICAL CHARACTERISTICS (V_{CC} = Full Range, T_A = -40°C to $+85^{\circ}\text{C}$ unless otherwise noted. typical values are at T_A = $+25^{\circ}\text{C}$, V_{CC} = 5V for L/M/J, 3.3V for T/S, 3.0V for R) (Note NO TAG)

Symbol	Characteristic	Min	Typ	Max	Unit
	V_{CC} Range				V
	$T_A = 0^{\circ}\text{C}$ to $+70^{\circ}\text{C}$	1.0	—	5.5	
	$T_A = -40^{\circ}\text{C}$ to $+85^{\circ}\text{C}$	1.2	—	5.5	
I_{CC}	Supply Current				μA
	HG8xxL/M/J: $V_{CC} < 5.5\text{V}$	—	24	60	
	HG8xxR/S/T: $V_{CC} < 3.6\text{V}$	—	17	50	
V_{TH}	Reset Threshold (Note NO TAG)				V
	HG8xxL: $T_A = 25^{\circ}\text{C}$	4.56	4.63	4.70	
	$T_A = -40^{\circ}\text{C}$ to $+85^{\circ}\text{C}$	4.50	—	4.75	
	HG8xxM: $T_A = 25^{\circ}\text{C}$	4.31	4.38	4.45	
	$T_A = -40^{\circ}\text{C}$ to $+85^{\circ}\text{C}$	4.25	—	4.50	
	HG809J: $T_A = 25^{\circ}\text{C}$	3.93	4.00	4.06	
	$T_A = -40^{\circ}\text{C}$ to $+85^{\circ}\text{C}$	3.89	—	4.10	
	HG8xxT: $T_A = 25^{\circ}\text{C}$	3.04	3.08	3.11	
	$T_A = -40^{\circ}\text{C}$ to $+85^{\circ}\text{C}$	3.00	—	3.15	
	HG8xxS: $T_A = 25^{\circ}\text{C}$	2.89	2.93	2.96	
	$T_A = -40^{\circ}\text{C}$ to $+85^{\circ}\text{C}$	2.85	—	3.00	
	HG8xxR: $T_A = 25^{\circ}\text{C}$	2.59	2.63	2.66	
	$T_A = -40^{\circ}\text{C}$ to $+85^{\circ}\text{C}$	2.55	—	2.70	
	Reset Threshold Temperature Coefficient	—	30	—	ppm/ $^{\circ}\text{C}$
	V_{CC} to Reset Delay $V_{CC} = V_{TH}$ to $(V_{TH} - 100\text{mV})$	—	20	—	μsec
	Reset Active Timeout Period	140	240	560	msec
V_{OL}	RESET Output Voltage Low (HG809)				V
	HG809R/S/T: $V_{CC} = V_{TH}$ min, $I_{SINK} = 1.2\text{mA}$	—	—	0.3	
	HG809L/M/J: $V_{CC} = V_{TH}$ min, $I_{SINK} = 3.2\text{mA}$	—	—	0.4	
	$V_{CC} > 1.0\text{V}$, $I_{SINK} = 50\mu\text{A}$	—	—	0.3	
V_{OH}	RESET Output Voltage High (HG809)				V
	HG809R/S/T: $V_{CC} > V_{TH}$ max, $I_{SOURCE} = 500\mu\text{A}$	$0.8 V_{CC}$	—	—	
	HG809L/M/J: $V_{CC} > V_{TH}$ max, $I_{SOURCE} = 800\mu\text{A}$	$V_{CC} - 1.5$	—	—	
V_{OL}	RESET Output Voltage Low (HG810)				V
	HG810R/S/T: $V_{CC} = V_{TH}$ max, $I_{SINK} = 1.2\text{mA}$	—	—	0.3	
	HG810L/M/J: $V_{CC} = V_{TH}$ max, $I_{SINK} = 3.2\text{mA}$	—	—	0.4	
V_{OH}	RESET Output Voltage High (HG810)				V
	$1.8 < V_{CC} < V_{TH}$ min, $I_{SOURCE} = 150\mu\text{A}$	$0.8 V_{CC}$	—	—	

1. Production testing done at $T_A = 25^{\circ}\text{C}$, over temperature limits guaranteed by design.

PIN DESCRIPTION

Pin No.	Symbol	Description
1	GND	Ground
2	RESET (HG809)	RESET output remains low while V_{CC} is below the reset voltage threshold, and for 240msec (typ.) after V_{CC} rises above reset threshold
2	RESET (HG810)	RESET output remains high while V_{CC} is below the reset voltage threshold, and for 240msec (typ.) after V_{CC} rises above reset threshold
3	V_{CC}	Supply Voltage (typ.)

APPLICATIONS INFORMATION

V_{CC} Transient Rejection

The HG809/810 provides accurate V_{CC} monitoring and reset timing during power-up, power-down, and brownout/sag conditions, and rejects negative-going transients (glitches) on the power supply line. Figure 1 shows the maximum transient duration vs. maximum negative excursion (overdrive) for glitch rejection. Any combination of duration and overdrive which lies **under** the curve will **not** generate a reset signal. Combinations above the curve are detected as a brownout or power-down. Transient immunity can be improved by adding a capacitor in close proximity to the V_{CC} pin of the HG809/810.

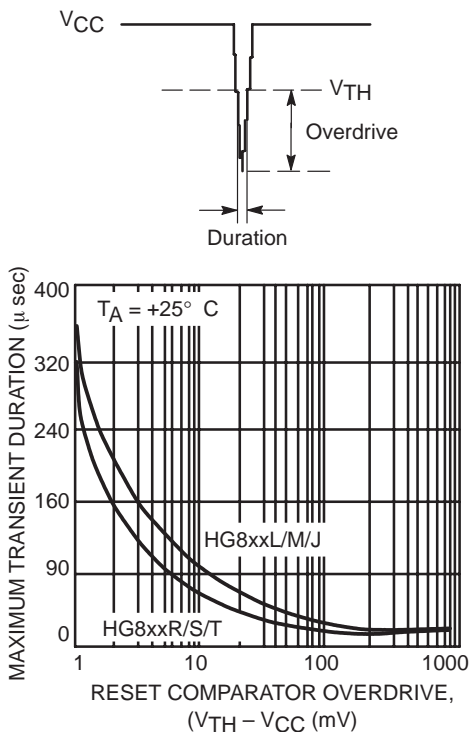

Figure 1. Maximum Transient Duration vs. Overdrive for Glitch Rejection at 25° C

RESET Signal Integrity During Power-Down

The HG809 RESET output is valid to V_{CC} = 1.0V. Below this voltage the output becomes an "open circuit" and does not sink current. This means CMOS logic inputs to the μP will be floating at an undetermined voltage. Most digital systems are completely shutdown well above this voltage. However, in situations where RESET must be maintained valid to V_{CC} = 0V, a pull-down resistor must be connected from RESET to ground to discharge stray capacitances and

hold the output low (Figure 2). This resistor value, though not critical, should be chosen such that it does not appreciably load RESET under normal operation (100kΩ will be suitable for most applications). Similarly, a pull-up resistor to V_{CC} is required for the HG810 to ensure a valid high RESET for V_{CC} below 1.0V.

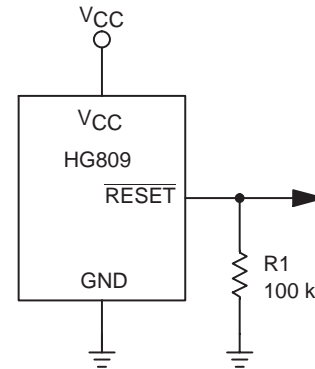

Figure 2. Ensuring RESET Valid to V_{CC} = 0 V

Processors With Bidirectional I/O Pins

Some μP's (such as Motorola 68HC11) have bi-directional reset pins. Depending on the current drive capability of the processor pin, an indeterminate logic level may result if there is a logic conflict. This can be avoided by adding a 4.7kΩ resistor in series with the output of the HG809/810 (Figure 3). If there are other components in the system which require a reset signal, they should be buffered so as not to load the reset line. If the other components are required to follow the reset I/O of the μP, the buffer should be connected as shown with the solid line.

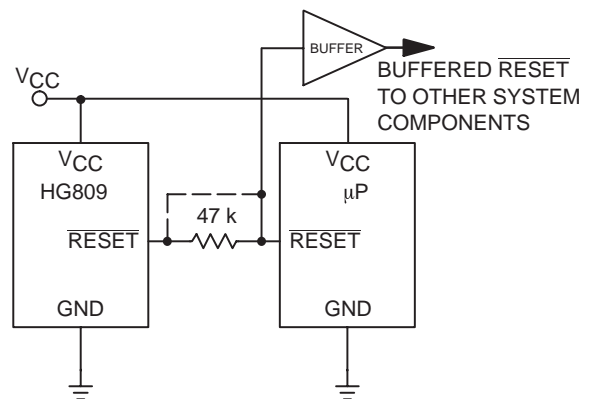

Figure 3. Interfacing to Bidirectional Reset I/O

TYPICAL CHARACTERISTICS

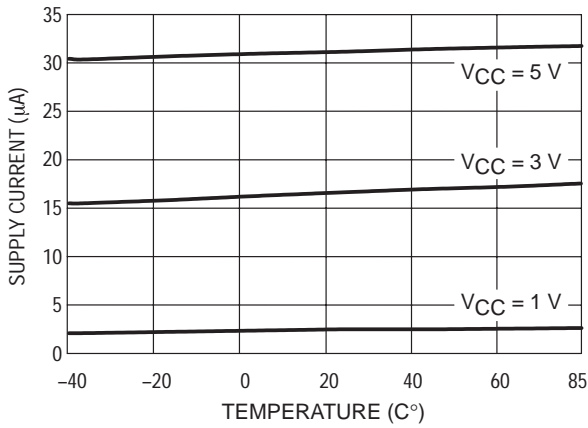

Figure 4. Supply Current vs Temperature (No Load, HG8xxR/S/T)

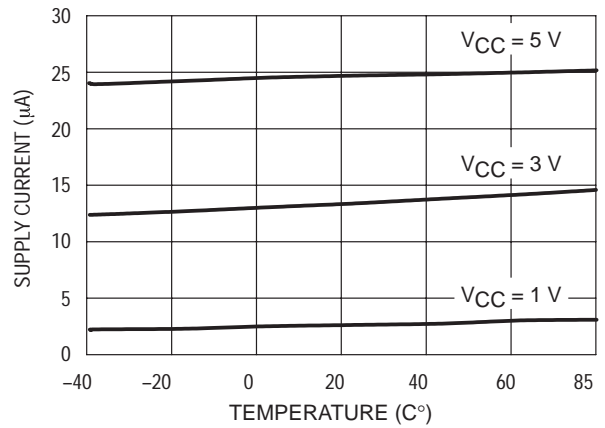

Figure 5. Supply Current vs Temperature (No Load, HG8xxL/M/J)

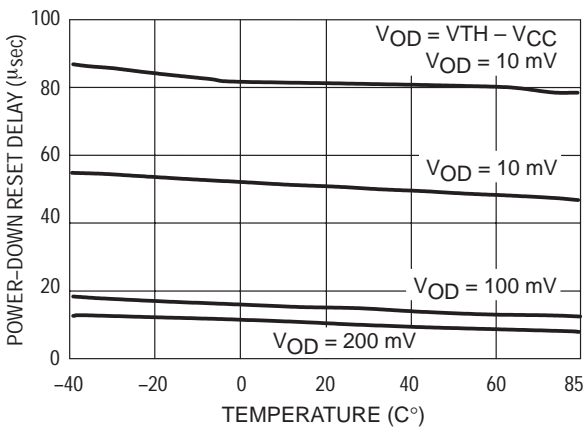

Figure 6. Power-Down Reset Delay vs Temperature and Overdrive (HG8xxR/S/T)

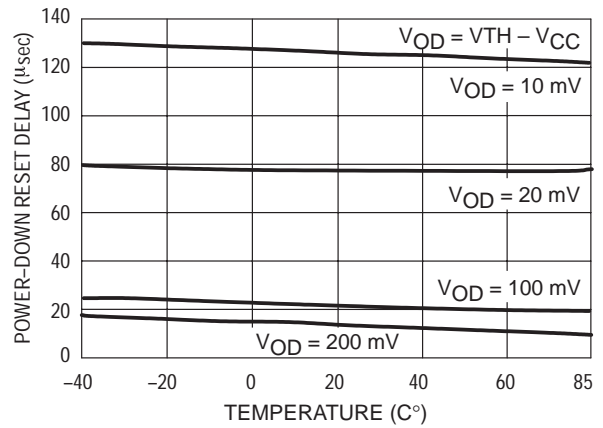

Figure 7. Power-Down Reset Delay vs Temperature and Overdrive (HG8xxL/M/J)

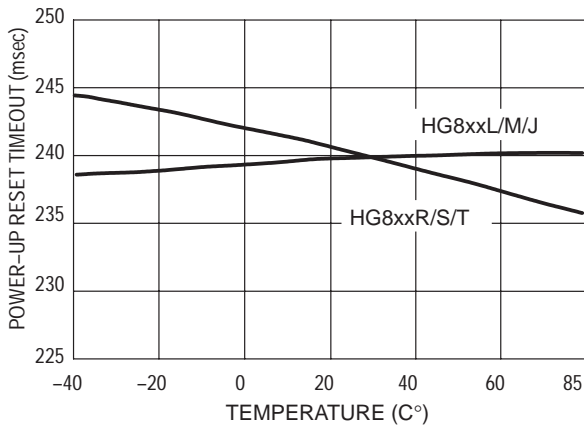

Figure 8. Power-Up Reset Timeout vs Temperature

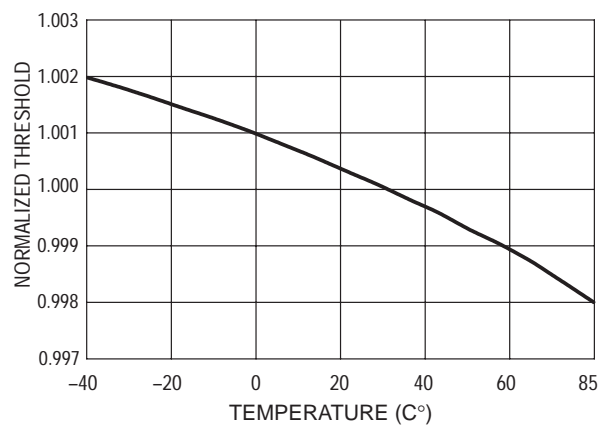

Figure 9. Normalized Reset Threshold vs Temperature

Important statement:

Huaguan Semiconductor Co,Ltd. reserves the right to change the products and services provided without notice. Customers should obtain the latest relevant information before ordering, and verify the timeliness and accuracy of this information.

Customers are responsible for complying with safety standards and taking safety measures when using our products for system design and machine manufacturing to avoid potential risks that may result in personal injury or property damage.

Our products are not licensed for applications in life support, military, aerospace, etc., so we do not bear the consequences of the application of these products in these fields.

Our documentation is only permitted to be copied without any tampering with the content, so we do not accept any responsibility or liability for the altered documents.

X-ON Electronics

Largest Supplier of Electrical and Electronic Components

Click to view similar products for [Supervisory Circuits](#) category:

Click to view products by [HGSEMI](#) manufacturer:

Other Similar products are found below :

[NCP304LSQ40T1G](#) [CAT1161LI-25-G](#) [CAT853STBI-T3](#) [TC54VN2402EMB713](#) [MCP1316MT-45GE/OT](#) [MCP1316MT-23LI/OT](#)
[MCP1316T-26LE/OT](#) [DS1232L](#) [NCV302HSN45T1G](#) [MCP1316T-23LI/OT](#) [PT7M6130NLTA3EX](#) [S-1000N28-I4T1U](#) [CAT1161LI-28-G](#)
[MCP1321T-29AE/OT](#) [MCP1320T-31KE/OT](#) [S-1000N23-I4T1U](#) [S-1000N19-I4T1U](#) [CAT824UTDI-GT3](#) [TC54VC2502ECB713](#) [MCP1317T-25LE/OT](#) [PT7M6133NLTA3EX](#) [PT7M6127NLTA3EX](#) [BD48E23G-TR](#) [BD48E49G-TR](#) [BD48E52G-TR](#) [MP6412GQGU-Z](#)
[XC61GN2502HR-G](#) [HG810RM3/TR](#) [ME2808A33XG](#) [ME2801A33M3G](#) [SGM809B-RXN3LG/TR](#) [HT7033S](#) [UM803RS](#) [UM805RE](#)
[BL8506-40CRM](#) [SSP61CN1902MR](#) [MAX809C263NR](#) [HE61CN2402MR](#) [SL61CC2702MR-G](#) [UM810MS](#) [MAX809C293NR](#)
[MAX809C308NR](#) [HE61CN2702MR](#) [UM811SE](#) [XC61CN1902MR](#) [BD48K34G-TL](#) [BL8506-20CRM](#) [XC61CC1502MR](#) [XC61CN1802MR](#)
[BL8509CCB3TR263DC](#)