

## High speed CAN transceiver

### FEATURES

- Fully compatible with the ISO 11898 standard
- High speed (up to 1 MBaud)
- Very low-current standby mode with remote wake-up capability via the bus
- Very low ElectroMagnetic Emission (EME)
- Differential receiver with high common-mode range for ElectroMagnetic Immunity (EMI)
- Transceiver in unpowered state disengages from the bus (zero load)
- Input levels compatible with 3.3 V and 5 V devices
- Voltage source for stabilizing the recessive bus level if split termination is used (further improvement of EME)
- At least 110 nodes can be connected
- Transmit Data (TXD) dominant time-out function
- Bus pins protected against transients in automotive environments
- Bus pins and pin SPLIT short-circuit proof to battery and ground
- Thermally protected.

### GENERAL DESCRIPTION

The HGA1040 is the interface between the Controller Area Network (CAN) protocol controller and the physical bus. It is primarily intended for high speed applications, up to 1 MBaud, in passenger cars. The device provides differential transmit capability to the bus and differential receive capability to the CAN controller.

The HGA1040 is the next step up from the HGA1050 high speed CAN transceiver. Being pin compatible and offering the same excellent EMC performance, the HGA1040 also features:

- An ideal passive behaviour when supply voltage is off
- A very low-current standby mode with remote wake-up capability via the bus.

This makes the HGA1040 an excellent choice in nodes which can be in power-down or standby mode in partially powered networks.

### QUICK REFERENCE DATA

SYMBOL	PARAMETER	CONDITIONS	MIN.	MAX.	UNIT
$V_{CC}$	supply voltage	operating range	4.75	5.25	V
$I_{CC}$	supply current	standby mode	5	15	$\mu$ A
$V_{CANH}$	DC voltage on pin CANH	$0 < V_{CC} < 5.25$ V; no time limit	-27	+40	V
$V_{CANL}$	DC voltage on pin CANL	$0 < V_{CC} < 5.25$ V; no time limit	-27	+40	V
$V_{SPLIT}$	DC voltage on pin SPLIT	$0 < V_{CC} < 5.25$ V; no time limit	-27	+40	V
$V_{esd}$	electrostatic discharge voltage	Human Body Model (HBM) pins CANH, CANL and SPLIT all other pins	-6 -4	+6 +4	kV kV
$t_{PD(TXD-RXD)}$	propagation delay TXD to RXD	$V_{STB} = 0$ V	40	255	ns
$T_{vj}$	virtual junction temperature		-40	+150	$^{\circ}$ C

**BLOCK DIAGRAM**

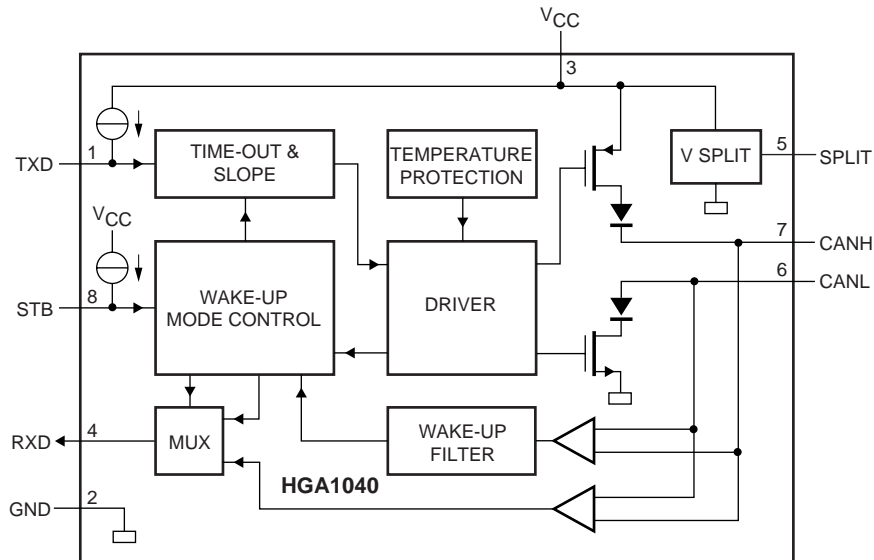

Fig.1 Block diagram.

**PINNING**

SYMBOL	PIN	DESCRIPTION
TXD	1	transmit data input
GND	2	ground supply
V <sub>CC</sub>	3	supply voltage
RXD	4	receive data output; reads out data from the bus lines
SPLIT	5	common-mode stabilization output
CANL	6	LOW-level CAN bus line
CANH	7	HIGH-level CAN bus line
STB	8	standby mode control input

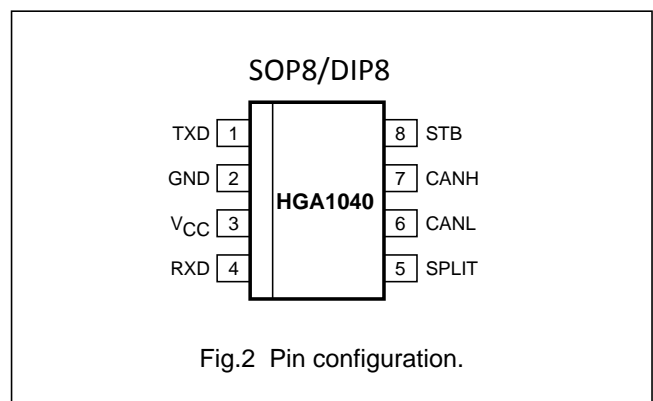

Fig.2 Pin configuration.

**FUNCTIONAL DESCRIPTION**

**Operating modes**

The HGA1040 provides two modes of operation which are selectable via pin STB.

**Table 1** Operating modes

MODE	PIN STB	PIN RXD	
		LOW	HIGH
normal	LOW	bus dominant	bus recessive
standby	HIGH	wake-up request detected	no wake-up request detected

**NORMAL MODE**

In this mode the transceiver is able to transmit and receive data via the bus lines CANH and CANL. See Fig.1 for the block diagram. The differential receiver converts the analog data on the bus lines into digital data which is output to pin RXD via the multiplexer (MUX). The slope of the output signals on the bus lines is fixed and optimized in a way that lowest ElectroMagnetic Emission (EME) is guaranteed.

**STANDBY MODE**

In this mode the transmitter and receiver are switched off, and the low-power differential receiver will monitor the bus lines. A HIGH level on pin STB activates this low-power receiver and the wake-up filter, and after  $t_{BUS}$  the state of the CAN bus is reflected on pin RXD.

The supply current on  $V_{CC}$  is reduced to a minimum in such a way that ElectroMagnetic Immunity (EMI) is guaranteed and a wake-up event on the bus lines will be recognized.

In this mode the bus lines are terminated to ground to reduce the supply current ( $I_{CC}$ ) to a minimum. A diode is added in series with the high-side driver of RXD to prevent a reverse current from RXD to  $V_{CC}$  in the unpowered state. In normal mode this diode is bypassed. This diode is not bypassed in standby mode to reduce current consumption.

**Split circuit**

Pin SPLIT provides a DC stabilized voltage of  $0.5V_{CC}$ . It is turned on only in normal mode. In standby mode pin SPLIT is floating. The  $V_{SPLIT}$  circuit can be used to stabilize the recessive common-mode voltage by connecting pin SPLIT

to the centre tap of the split termination (see Fig.4). In case of a recessive bus voltage  $<0.5V_{CC}$  due to the presence of an unpowered transceiver in the network with a significant leakage current from the bus lines to ground, the split circuit will stabilize this recessive voltage to  $0.5V_{CC}$ . So a start of transmission does not cause a step in the common-mode signal which would lead to poor ElectroMagnetic Emission (EME) behaviour.

**Wake-up**

In the standby mode the bus lines are monitored via a low-power differential comparator. Once the low-power differential comparator has detected a dominant bus level for more than  $t_{BUS}$ , pin RXD will become LOW.

**Over-temperature detection**

The output drivers are protected against over-temperature conditions. If the virtual junction temperature exceeds the shutdown junction temperature  $T_{j(sd)}$ , the output drivers will be disabled until the virtual junction temperature becomes lower than  $T_{j(sd)}$  and TXD becomes recessive again. By including the TXD condition, the occurrence of output driver oscillation due to temperature drifts is avoided.

**TXD dominant time-out function**

A 'TXD dominant time-out' timer circuit prevents the bus lines from being driven to a permanent dominant state (blocking all network communication) if pin TXD is forced permanently LOW by a hardware and/or software application failure. The timer is triggered by a negative edge on pin TXD.

If the duration of the LOW level on pin TXD exceeds the internal timer value ( $t_{dom}$ ), the transmitter is disabled, driving the bus lines into a recessive state. The timer is reset by a positive edge on pin TXD. The TXD dominant time-out time  $t_{dom}$  defines the minimum possible bit rate of 40 kBaud.

**Fail-safe features**

Pin TXD provides a pull-up towards  $V_{CC}$  in order to force a recessive level in case pin TXD is unpowered.

Pin STB provides a pull-up towards  $V_{CC}$  in order to force the transceiver into standby mode in case pin STB is unpowered.

In the event that the  $V_{CC}$  is lost, pins TXD, STB and RXD will become floating to prevent reverse supplying conditions via these pins.

**LIMITING VALUES**

In accordance with the Absolute Maximum Rating System.

SYMBOL	PARAMETER	CONDITIONS	MIN.	MAX.	UNIT
V <sub>CC</sub>	supply voltage	no time limit	-0.3	+6	V
		operating range	4.75	5.25	V
V <sub>TXD</sub>	DC voltage on pin TXD		-0.3	V <sub>CC</sub> + 0.3	V
V <sub>RXD</sub>	DC voltage on pin RXD		-0.3	V <sub>CC</sub> + 0.3	V
V <sub>STB</sub>	DC voltage on pins STB		-0.3	V <sub>CC</sub> + 0.3	V
V <sub>CANH</sub>	DC voltage on pin CANH	0 < V <sub>CC</sub> < 5.25 V; no time limit	-27	+40	V
V <sub>CANL</sub>	DC voltage on pin CANL	0 < V <sub>CC</sub> < 5.25 V; no time limit	-27	+40	V
V <sub>SPLIT</sub>	DC voltage on pin SPLIT	0 < V <sub>CC</sub> < 5.25 V; no time limit	-27	+40	V
V <sub>trt</sub>	transient voltages on pins CANH, CANL and SPLIT	according to ISO 7637; see Fig.5	-200	+200	V
V <sub>esd</sub>	electrostatic discharge voltage	Human Body Model (HBM); note 1			
		pins CANH and CANL and SPLIT	-6	+6	kV
		all other pins	-4	+4	kV
		Machine Model (MM); note 2	-200	+200	V
T <sub>vj</sub>	virtual junction temperature	note 3	-40	+150	°C
T <sub>stg</sub>	storage temperature		-55	+150	°C

**Notes**

- Equivalent to discharging a 100 pF capacitor via a 1.5 kΩ series resistor.
- Equivalent to discharging a 200 pF capacitor via a 0.75 μH series inductor and a 10 Ω series resistor.
- Junction temperature in accordance with IEC 60747-1. An alternative definition of T<sub>vj</sub> is:  $T_{vj} = T_{amb} + P \times R_{th(vj-amb)}$ , where R<sub>th(vj-amb)</sub> is a fixed value to be used for the calculating of T<sub>vj</sub>. The rating for T<sub>vj</sub> limits the allowable combinations of power dissipation (P) and ambient temperature (T<sub>amb</sub>).

**THERMAL CHARACTERISTICS**

In accordance with IEC 60747-1.

SYMBOL	PARAMETER	CONDITIONS	VALUE	UNIT
R <sub>th(vj-a)</sub>	thermal resistance from virtual junction to ambient in SO8 package	in free air	145	K/W
R <sub>th(vj-s)</sub>	thermal resistance from virtual junction to substrate of bare die	in free air	50	K/W

## CHARACTERISTICS

$V_{CC} = 4.75$  to  $5.25$  V,  $T_{vj} = -40$  to  $+150$  °C and  $R_L = 60$   $\Omega$  unless specified otherwise; all voltages are defined with respect to ground; positive currents flow into the IC; note 1.

SYMBOL	PARAMETER	CONDITIONS	MIN.	TYP.	MAX.	UNIT
<b>Supply (pin V<sub>CC</sub>)</b>						
I <sub>CC</sub>	supply current	standby mode	5	10	15	$\mu$ A
		normal mode recessive; $V_{TXD} = V_{CC}$ dominant; $V_{TXD} = 0$ V	2.5 30	5 50	10 70	mA mA
<b>Transmit data input (pin TXD)</b>						
V <sub>IH</sub>	HIGH-level input voltage		2	–	$V_{CC} + 0.3$	V
V <sub>IL</sub>	LOW-level input voltage		–0.3	–	+0.8	V
I <sub>IH</sub>	HIGH-level input current	$V_{TXD} = V_{CC}$	–5	0	+5	$\mu$ A
I <sub>IL</sub>	LOW-level input current	normal mode; $V_{TXD} = 0$ V	–100	–200	–300	$\mu$ A
C <sub>i</sub>	input capacitance	not tested	–	5	10	pF
<b>Standby mode control input (pin STB)</b>						
V <sub>IH</sub>	HIGH-level input voltage		2	–	$V_{CC} + 0.3$	V
V <sub>IL</sub>	LOW-level input voltage		–0.3	–	+0.8	V
I <sub>IH</sub>	HIGH-level input current	$V_{STB} = V_{CC}$	–	0	–	$\mu$ A
I <sub>IL</sub>	LOW-level input current	$V_{STB} = 0$ V	–1	–4	–10	$\mu$ A
<b>Receive data output (pin RXD)</b>						
V <sub>OH</sub>	HIGH-level output voltage	standby mode; $I_{RXD} = -100$ $\mu$ A	$V_{CC} - 1.1$	$V_{CC} - 0.7$	$V_{CC} - 0.4$	V
I <sub>OH</sub>	HIGH-level output current	normal mode; $V_{RXD} = V_{CC} - 0.4$ V	–0.1	–0.4	–1	mA
I <sub>OL</sub>	LOW-level output current	$V_{RXD} = 0.4$ V	2	6	12	mA
<b>Common-mode stabilization output (pin SPLIT)</b>						
V <sub>O</sub>	output voltage	normal mode; $-500$ $\mu$ A $< I_O < +500$ $\mu$ A	$0.3V_{CC}$	$0.5V_{CC}$	$0.7V_{CC}$	V
I <sub>L</sub>	leakage current	standby mode; $-22$ V $< V_{SPLIT} < +35$ V	–	0	5	$\mu$ A
<b>Bus lines (pins CANH and CANL)</b>						
V <sub>O(dom)</sub>	dominant output voltage	$V_{TXD} = 0$ V pin CANH	3	3.6	4.25	V
		pin CANL	0.5	1.4	1.75	V
V <sub>O(dom)(m)</sub>	matching of dominant output voltage ( $V_{CC} - V_{CANH} - V_{CANL}$ )		–100	0	+150	mV
V <sub>O(dif)(bus)</sub>	differential bus output voltage ( $V_{CANH} - V_{CANL}$ )	$V_{TXD} = 0$ V; dominant; $45$ $\Omega < R_L < 65$ $\Omega$	1.5	–	3.0	V
		$V_{TXD} = V_{CC}$ ; recessive; no load	–50	–	+50	mV

SYMBOL	PARAMETER	CONDITIONS	MIN.	TYP.	MAX.	UNIT
V <sub>O(reces)</sub>	recessive output voltage	normal mode; V <sub>TXD</sub> = V <sub>CC</sub> ; no load	2	0.5V <sub>CC</sub>	3	V
		standby mode; no load	-0.1	0	+0.1	V
I <sub>O(sc)</sub>	short-circuit output current	V <sub>TXD</sub> = 0 V pin CANH; V <sub>CANH</sub> = 0 V	-40	-70	-95	mA
		pin CANL; V <sub>CANL</sub> = 40 V	40	70	100	mA
I <sub>O(reces)</sub>	recessive output current	-27 V < V <sub>CAN</sub> < +32 V	-2.5	-	+2.5	mA
V <sub>dif(th)</sub>	differential receiver threshold voltage	-12 V < V <sub>CANL</sub> < +12 V; -12 V < V <sub>CANH</sub> < +12 V normal mode (see Fig.6)	0.5	0.7	0.9	V
		standby mode	0.4	0.7	1.15	V
V <sub>hys(dif)</sub>	differential receiver hysteresis voltage	normal mode; -12 V < V <sub>CANL</sub> < +12 V; -12 V < V <sub>CANH</sub> < +12 V	50	70	100	mV
I <sub>LI</sub>	input leakage current	V <sub>CC</sub> = 0 V; V <sub>CANH</sub> = V <sub>CANL</sub> = 5 V	-5	0	+5	μA
R <sub>i(cm)</sub>	common-mode input resistance	standby or normal mode	15	25	35	kΩ
R <sub>i(cm)(m)</sub>	common-mode input resistance matching	V <sub>CANH</sub> = V <sub>CANL</sub>	-3	0	+3	%
R <sub>i(dif)</sub>	differential input resistance	standby or normal mode	25	50	75	kΩ
C <sub>i(cm)</sub>	common-mode input capacitance	V <sub>TXD</sub> = V <sub>CC</sub> ; not tested	-	-	20	pF
C <sub>i(dif)</sub>	differential input capacitance	V <sub>TXD</sub> = V <sub>CC</sub> ; not tested	-	-	10	pF
<b>Timing characteristics; see Fig.8</b>						
t <sub>d(TXD-BUSon)</sub>	delay TXD to bus active	normal mode	25	70	110	ns
t <sub>d(TXD-BUSoff)</sub>	delay TXD to bus inactive		10	50	95	ns
t <sub>d(BUSon-RXD)</sub>	delay bus active to RXD		15	65	115	ns
t <sub>d(BUSoff-RXD)</sub>	delay bus inactive to RXD		35	100	160	ns
t <sub>PD(TXD-RXD)</sub>	propagation delay TXD to RXD	V <sub>STB</sub> = 0 V	40	-	255	ns
t <sub>dom(TXD)</sub>	TXD dominant time-out	V <sub>TXD</sub> = 0 V	300	600	1000	μs
t <sub>BUS</sub>	dominant time for wake-up via bus	standby mode	0.75	1.75	5	μs
t <sub>d(stb-norm)</sub>	delay standby mode to normal mode	normal mode	5	7.5	10	μs
<b>Thermal shutdown</b>						
T <sub>J(sd)</sub>	shutdown junction temperature		155	165	180	°C

**Note**

1. All parameters are guaranteed over the virtual junction temperature range by design, but only 100% tested at 125 °C ambient temperature for dies on wafer level, and in addition to this 100% tested at 25 °C ambient temperature for cased products; unless specified otherwise. For bare dies, all parameters are only guaranteed with the backside of the die connected to ground.

**APPLICATION AND TEST INFORMATION**

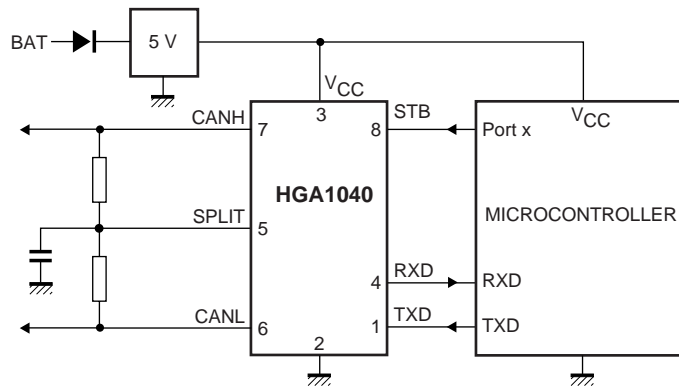

Fig.3 Typical application for 5 V microcontroller.

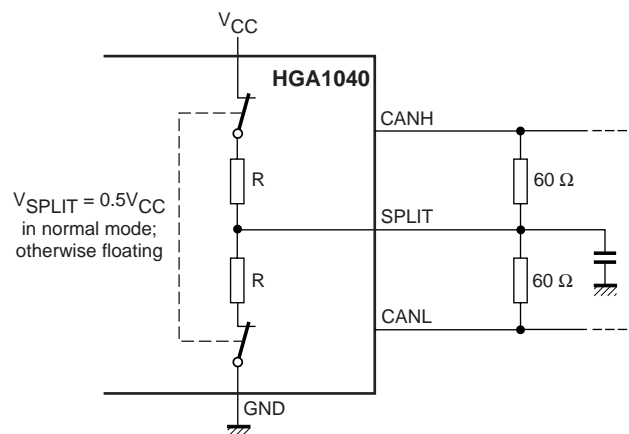

Fig.4 Stabilization circuitry and application.

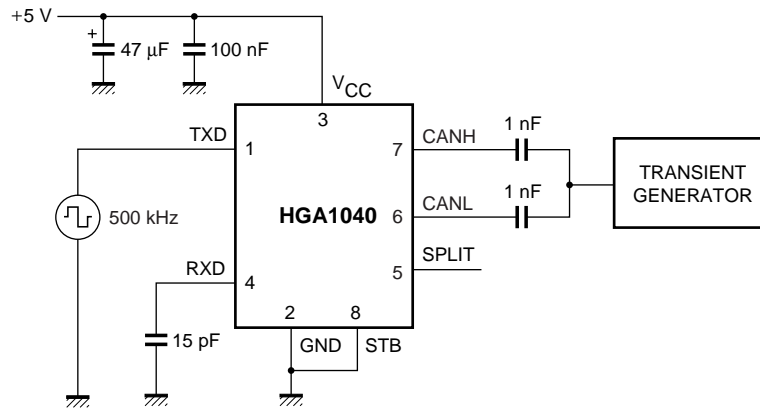

Fig.5 Test circuit for automotive transients.

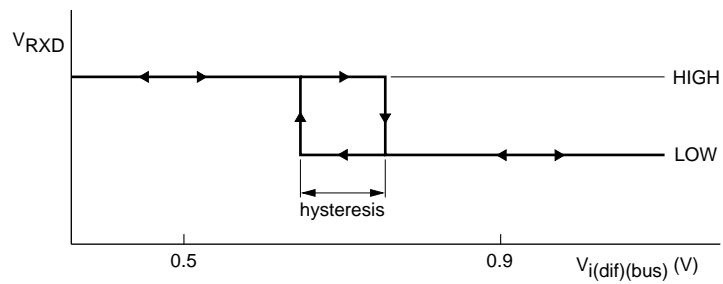

Fig.6 Hysteresis of the receiver.



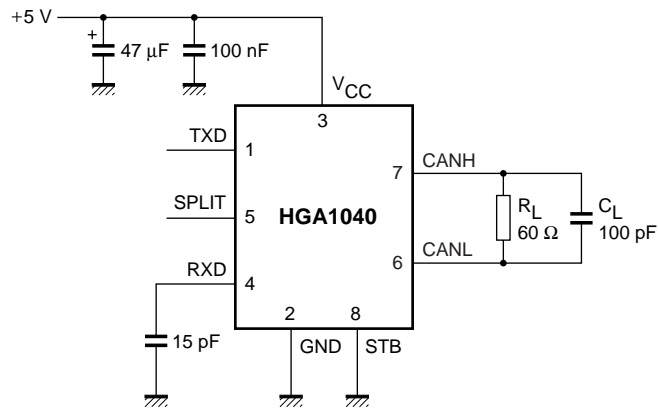
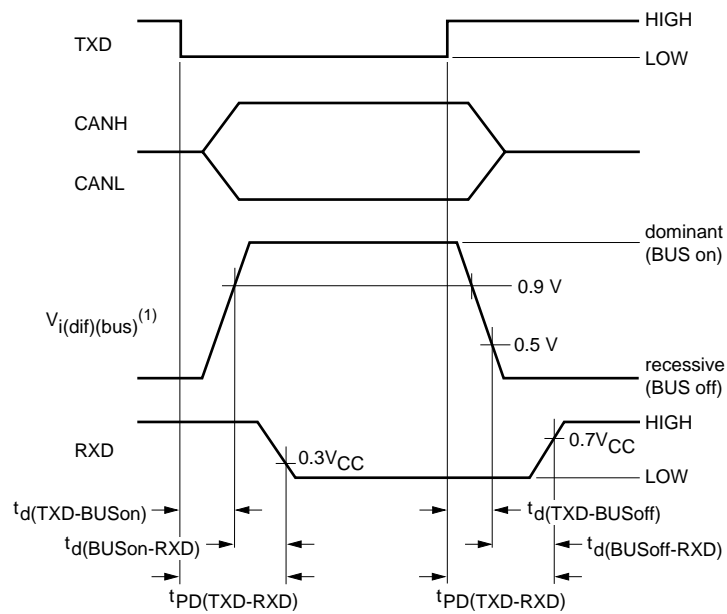

Fig.7 Test circuit for timing characteristics.



(1)  $V_{i(dif)(bus)} = V_{CANH} - V_{CANL}$

Fig.8 Timing diagram.

PACKAGE

SOP8

UNIT: mm							
DIM.	MIN	TYP	MAX	DIM.	MIN	TYP	MAX
A	4.520	4.570	4.620	a	0.400	0.420	0.440
A1	0.100	-	0.250	b	1.260	1.270	1.280
B	4.800	4.920	5.100	Q	0°	-	8°
C	5.800	6.100	6.250				
C1	3.800	3.900	4.000				
D	0.400	-	0.950				

DIP8

UNIT: mm							
DIM.	MIN	TYP	MAX	DIM.	MIN	TYP	MAX
A	6.100	6.300	6.680	a	1.504	1.524	1.544
B	9.000	9.200	9.500	b	-	0.889	-
D	8.400	8.700	9.000	c	0.437	0.457	0.477
D1	7.42	7.62	7.82	d	2.530	2.540	2.550
E	3.100	3.300	3.550	L	0.500	-	0.700
				L1	3.000	3.200	3.600

Important statement:

Huaguan Semiconductor Co,Ltd. reserves the right to change the products and services provided without notice. Customers should obtain the latest relevant information before ordering, and verify the timeliness and accuracy of this information.

Customers are responsible for complying with safety standards and taking safety measures when using our products for system design and machine manufacturing to avoid potential risks that may result in personal injury or property damage.

Our products are not licensed for applications in life support, military, aerospace, etc., so we do not bear the consequences of the application of these products in these fields.

Our documentation is only permitted to be copied without any tampering with the content, so we do not accept any responsibility or liability for the altered documents.

## X-ON Electronics

Largest Supplier of Electrical and Electronic Components

*Click to view similar products for [CAN Interface IC category](#):*

*Click to view products by [HGSEMI manufacturer](#):*

Other Similar products are found below :

[IFX1040SJ](#) [416694H](#) [MAX13052ASAT](#) [MAX3057ASAT](#) [MC33742PEP](#) [MCP25025-I/P](#) [MCP25055-I/SL](#) [MCP2561FD-EMF](#) [MCP2561-HMF](#) [MCP2515T-ESO](#) [MCP2561FD-HSN](#) [TJA1042T,118](#) [TJA1050T/CM](#) [TJA1052IT2Y](#) [IL41050TA-1E](#) [AMIS42770ICAW1G](#) [ATA6560-GBQW](#) [TJA1042T/1J](#) [TJA1042T/3/1J](#) [TJA1042TCM,118](#) [TJA1042T/CM,118](#) [TJA1051T/CM,118](#) [TJA1051T/E,118](#) [TJA1052IT/5Y](#) [UJA1078ATW/5V0/WDJ](#) [ATA6560-GAQW](#) [ATA6560-GAQW](#) [MCP2561FD-E/SN](#) [MCP25050-E/P](#) [MCP2515-I/ML](#) [SN65LBC031QD](#) [SN65LBC031DG4](#) [SN65HVD267DR](#) [MAX3050ASA+](#) [NCV7342D13R2G](#) [MAX13054ESA+](#) [TJA1050T/CM,118](#) [TJA1040T/CM,118](#) [SJA1000T/N1.118](#) [TJA1051TCM,118](#) [TJF1052IT5Y](#) [TJA1042T31J](#) [TJA1042T/3/CM,118](#) [MCP2562FD-E/P](#) [MAX13052ASA+T](#) [MCP2561-EMF](#) [MCP2561FD-E/P](#) [MCP2562FD-EMF](#) [MCP25025-I/SL](#) [MCP2561FD-H/SN](#)