

600nA 14.5KHZ CMOS Rail-to-Rail IO Opamp with RF Filter

Features

- Single-Supply Operation from +1.4V ~ +5.5V
- Rail-to-Rail Input / Output
- Gain-Bandwidth Product: 14.5KHz (Typ)
- Low Input Bias Current: 1pA (Typ)
- Low Offset Voltage: 3mV (Max)
- Quiescent Current: 600nA per Amplifier (Typ)
- Chip Select with HGV6043NH(active High) and HGV6043NL(active Low)
- Operating Temperature: -40°C ~ +125°C
- Embedded RF Anti-EMI Filter
- Small Package:
HGV6041 Available in SOT23-5 and SC70-5 Packages
HGV6042 Available in SOP-8 and MSOP-8 Packages
HGV6043NH Available in SOT23-6 and SC70-6 Packages
HGV6043NL Available in SOT23-6 and SC70-6 Packages

General Description

The HGV604X family has a high gain-bandwidth product of 14.5KHz, a slew rate of 6V/ms, and a quiescent current of 600nA/amplifier at 5V. The HGV604X family is designed to provide optimal performance in low voltage and low noise systems. They provide rail-to-rail output swing into heavy loads. The input common mode voltage range includes ground, and the maximum input offset voltage is 3mV for HGV604X family. They are specified over the extended industrial temperature range (-40°C to +125°C). The operating range is from 1.4V to 5.5V. The HGV6041 single is available in Green SC70-5 and SOT23-5 packages. The HGV6042 Dual is available in Green SOP-8 and MSOP-8 packages. The HGV6043 single is available in Green SC70-6 and SOT23-6 packages.

Applications

- ASIC Input or Output Amplifier
- Sensor Interface
- Medical Communication
- Smoke Detectors
- Audio Output
- Piezoelectric Transducer Amplifier
- Medical Instrumentation
- Portable Systems

Pin Configuration

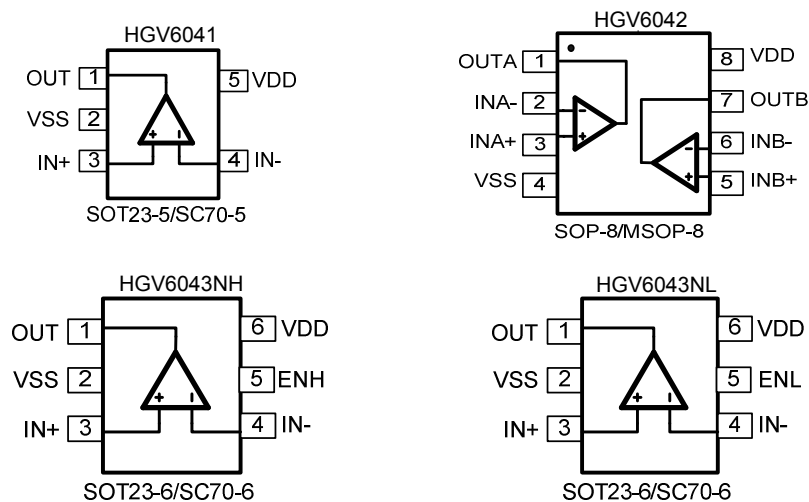

Figure 1. Pin Assignment Diagram

ORDERING INFORMATION

DEVICE	Package Type	MARKING	Packing	Packing Qty
HGV6041M5/TR	SOT23-5	6041	REEL	3000pcs/reel
HGV6041M7/TR	SC70-5	6041	REEL	3000pcs/reel
HGV6042M/TR	SOP8L	HGV6042	REEL	2500pcs/reel
HGV6042MM/TR	MSOP8L	HGV6042	REEL	3000pcs/reel
HGV6043NHM6/TR	SOT23-6	043H	REEL	3000pcs/reel
HGV6043NHM7/TR	SC70-6	043H	REEL	3000pcs/reel
HGV6043NLM6/TR	SOT23-6	043L	REEL	3000pcs/reel
HGV6043NLM7/TR	SC70-6	043L	REEL	3000pcs/reel

Absolute Maximum Ratings

Condition	Min	Max
Power Supply Voltage (V _{DD} to V _{SS})	-0.5V	+7.5V
Analog Input Voltage (IN+ or IN-)	V _{SS} -0.5V	V _{DD} +0.5V
PDB Input Voltage	V _{SS} -0.5V	+7V
Operating Temperature Range	-40°C	+125°C
Junction Temperature	+160°C	
Storage Temperature Range	-55°C	+150°C
Lead Temperature (soldering, 10sec)	+260°C	
Package Thermal Resistance (T_A=+25°C)		
SOP-8, θ_{JA}	125°C/W	
MSOP-8, θ_{JA}	216°C/W	
SOT23-5, θ_{JA}	190°C/W	
SOT23-6, θ_{JA}	190°C/W	
SC70-5, θ_{JA}	333°C/W	
SC70-6, θ_{JA}	333°C/W	
ESD Susceptibility		
HBM	6KV	
MM	300V	

Note: Stress greater than those listed under Absolute Maximum Ratings may cause permanent damage to the device. This is a stress rating only and functional operation of the device at these or any other conditions outside those indicated in the operational sections of this specification are not implied. Exposure to absolute maximum rating conditions for extended periods may affect reliability.

Electrical Characteristics

(At $V_S = +5V$, $R_L = 1M\Omega$ connected to $V_S/2$, and $V_{OUT} = V_S/2$, unless otherwise noted.)

PARAMETER	SYMBOL	CONDITIONS	HGV6041/6042/6043			
			TYP	MIN	MAX	UNITS
INPUT CHARACTERISTICS						
Input Offset Voltage	V_{OS}	$V_{CM} = V_S/2$	0.4		3	mV
Input Bias Current	I_B		1			pA
Input Offset Current	I_{OS}		1			pA
Common-Mode Voltage Range	V_{CM}	$V_S = 5.5V$	-0.1 to +5.6			V
Common-Mode Rejection Ratio	CMRR	$V_S = 5V, V_{CM} = -0.1V$ to 2.5V	78	66		dB
		$V_S = 5V, V_{CM} = -0.1V$ to 5.1V	84	67		
Open-Loop Voltage Gain	A_{OL}	$V_S=1.4V, R_L = 50k\Omega, V_O = V_S-0.1V$	86	75		dB
		$V_S=5V, R_L = 50k\Omega, V_O = V_S-0.1V$	93	84		
Input Offset Voltage Drift	$\Delta V_{OS}/\Delta T$		2.5			$\mu V/^\circ C$
OUTPUT CHARACTERISTICS						
Output Voltage Swing from Rail	V_{OH}	$V_S=1.4V, R_L = 50k\Omega$	1.395	1.390		V
	V_{OL}		4.5		10	mV
	V_{OH}	$V_S=5V, R_L = 50k\Omega$	4.997	4.990		V
	V_{OL}		3.5		10	mV
Output Current	I_{SOURCE}	$R_L = 10\Omega$ to $V_S/2$	20			mA
	I_{SINK}		20			
POWER SUPPLY						
Operating Voltage Range			1.4			V
			5.5			V
Power Supply Rejection Ratio	PSRR	$V_S = +1.4V$ to +5.5V, $V_{CM} = +0.5V$	80	77		dB
Quiescent Current / Amplifier	I_Q		600			nA
Shutdown Current / Amplifier	I_{Q_off}	HGV6043NH / HGV6043NL	54			nA
DYNAMIC PERFORMANCE (CL = 100pF)						
Gain-Bandwidth Product	GBP		14.5			KHz
Slew Rate	SR	$G = +1, 2V$ Output Step	6			V/ms

Typical Performance characteristics

At $T_A=+25^{\circ}\text{C}$, $V_S=+5\text{V}$, and $R_L=100\text{K}\Omega$ connected to $V_S/2$, unless otherwise noted.

Large Signal Inverting Pulse Response

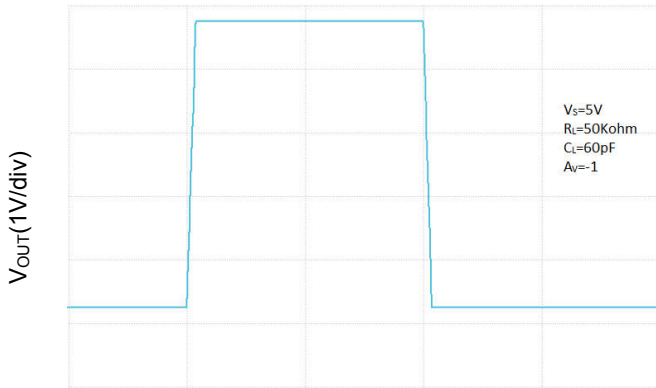

Large Signal Non-Inverting Pulse Response

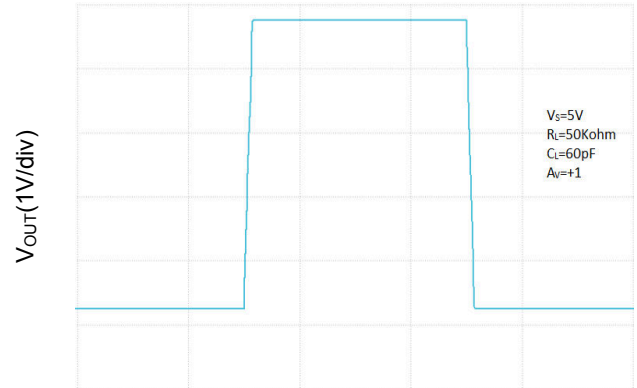

Time(10ms/div)

Small Signal Inverting Pulse Response

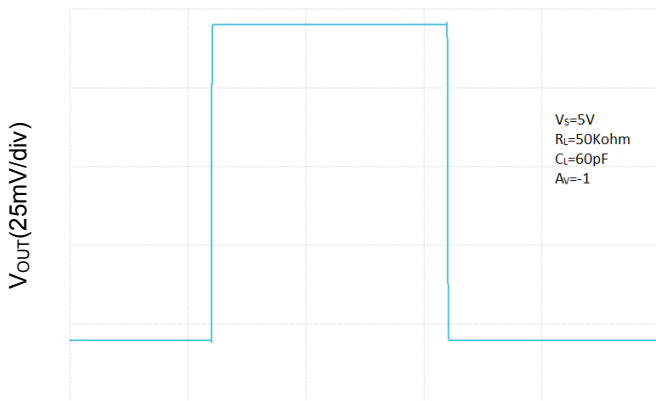

Time(10ms/div)

Small Signal Non-Inverting Pulse Response

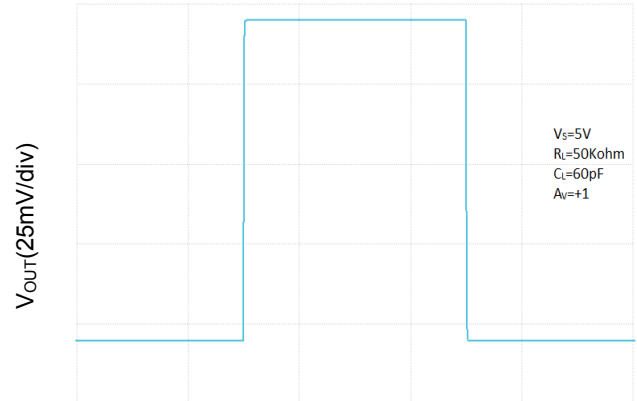

Time(10ms/div)

Typical Performance characteristics

At $T_A=+25^{\circ}\text{C}$, $V_S=+5\text{V}$, and $R_L=100\text{K}\Omega$ connected to $V_S/2$, unless otherwise noted.

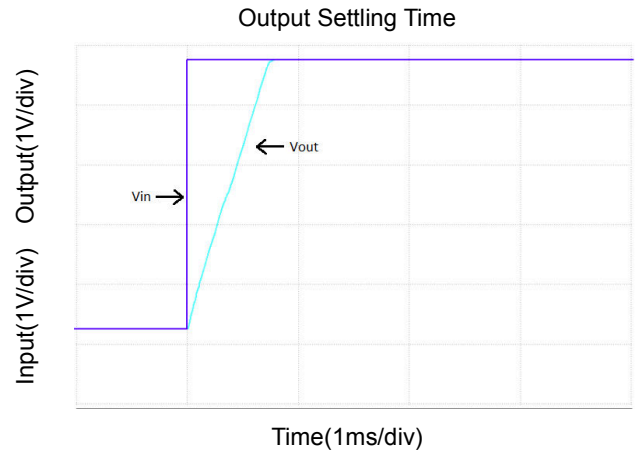
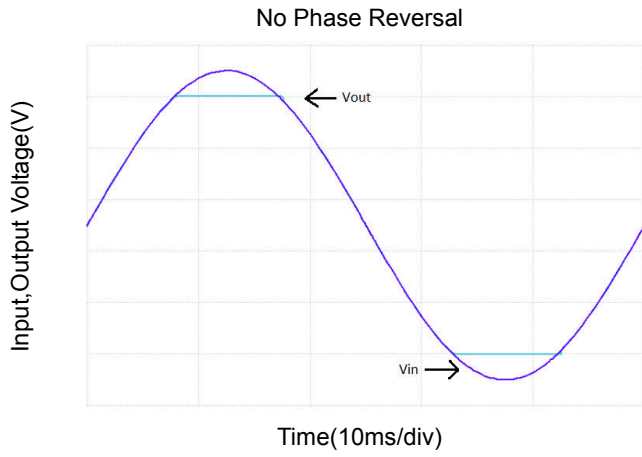

Application Note

Size

HGV604X family series op amps are unity-gain stable and suitable for a wide range of general-purpose applications. The small footprints of the HGV604X family packages save space on printed circuit boards and enable the design of smaller electronic products.

Power Supply Bypassing and Board Layout

HGV604X family series operates from a single 1.4V to 5.5V supply or dual $\pm 0.7V$ to $\pm 2.75V$ supplies. For best performance, a $0.1\mu F$ ceramic capacitor should be placed close to the V_{DD} pin in single supply operation. For dual supply operation, both V_{DD} and V_{SS} supplies should be bypassed to ground with separate $0.1\mu F$ ceramic capacitors.

Low Supply Current

The low supply current (typical 600nA per channel) of HGV604X family will help to maximize battery life. They are ideal for battery powered systems.

Operating Voltage

HGV604X family operates under wide input supply voltage (1.4V to 5.5V). In addition, all temperature specifications apply from $-40^{\circ}C$ to $+125^{\circ}C$. Most behavior remains unchanged throughout the full operating voltage range. These guarantees ensure operation throughout the single Li-Ion battery lifetime.

Rail-to-Rail Input

The input common-mode range of HGV604X family extends 100mV beyond the supply rails ($V_{SS}-0.1V$ to $V_{DD}+0.1V$). This is achieved by using complementary input stage. For normal operation, inputs should be limited to this range.

Rail-to-Rail Output

Rail-to-Rail output swing provides maximum possible dynamic range at the output. This is particularly important when operating in low supply voltages. The output voltage of HGV604X family can typically swing to less than 50mV from supply rail in light resistive loads ($>50k\Omega$).

Capacitive Load Tolerance

The HGV604X family is optimized for bandwidth and speed, not for driving capacitive loads. Output capacitance will create a pole in the amplifier's feedback path, leading to excessive peaking and potential oscillation. If dealing with load capacitance is a requirement of the application, the two strategies to consider are (1) using a small resistor in series with the amplifier's output and the load capacitance and (2) reducing the bandwidth of the amplifier's feedback loop by increasing the overall noise gain. Figure 2. shows a unity gain follower using the series resistor strategy. The resistor isolates the output from the capacitance and, more importantly, creates a zero in the feedback path that compensates for the pole created by the output capacitance.

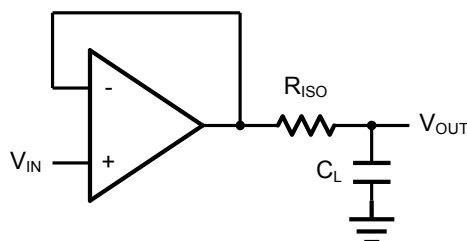

Figure 2. Indirectly Driving a Capacitive Load Using Isolation Resistor

The bigger the R_{ISO} resistor value, the more stable V_{OUT} will be. However, if there is a resistive load R_L in parallel with the capacitive load, a voltage divider (proportional to R_{ISO}/R_L) is formed, this will result in a gain error.

The circuit in Figure 3 is an improvement to the one in Figure 2. R_F provides the DC accuracy by feed-forward the V_{IN} to R_L . C_F and R_{ISO} serve to counteract the loss of phase margin by feeding the high frequency component of the output signal back to the amplifier's inverting input, thereby preserving the phase margin in the overall feedback loop. Capacitive drive can be increased by increasing the value of C_F . This in turn will slow down the pulse response.

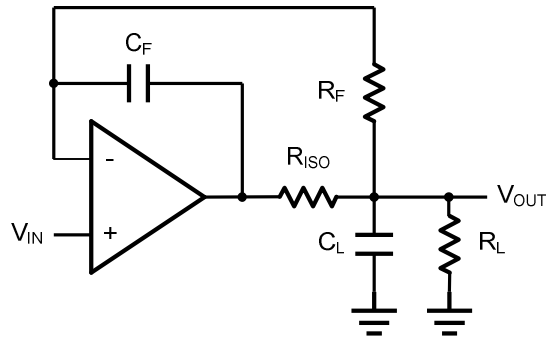

Figure 3. Indirectly Driving a Capacitive Load with DC Accuracy

Typical Application Circuits

Differential amplifier

The differential amplifier allows the subtraction of two input voltages or cancellation of a signal common to the two inputs. It is useful as a computational amplifier in making a differential to single-end conversion or in rejecting a common mode signal. Figure 4. shows the differential amplifier using HGV604X family.

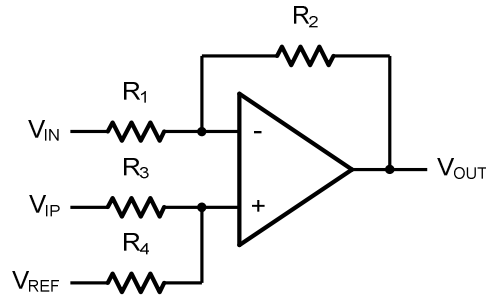

Figure 4. Differential Amplifier

$$V_{OUT} = \left(\frac{R_1 + R_2}{R_3 + R_4} \right) \frac{R_4}{R_1} V_{IN} - \frac{R_2}{R_1} V_{IP} + \left(\frac{R_1 + R_2}{R_3 + R_4} \right) \frac{R_3}{R_1} V_{REF}$$

If the resistor ratios are equal (i.e. $R_1 = R_3$ and $R_2 = R_4$), then

$$V_{OUT} = \frac{R_2}{R_1} (V_{IP} - V_{IN}) + V_{REF}$$

Low Pass Active Filter

The low pass active filter is shown in Figure 5. The DC gain is defined by $-R_2/R_1$. The filter has a -20dB/decade roll-off after its corner frequency $f_c = 1/(2\pi R_3 C_1)$.

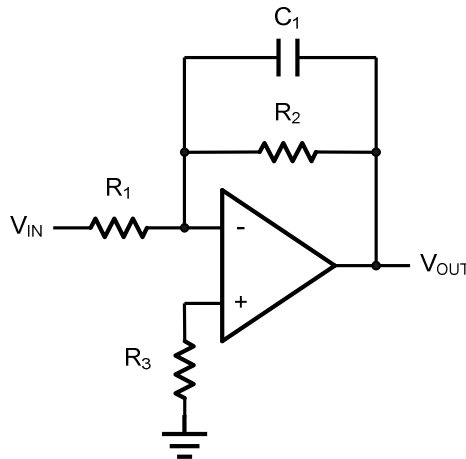

Figure 5. Low Pass Active Filter

Instrumentation Amplifier

The triple HGV604X family can be used to build a three-op-amp instrumentation amplifier as shown in Figure 6. The amplifier in Figure 6 is a high input impedance differential amplifier with gain of R_2/R_1 . The two differential voltage followers assure the high input impedance of the amplifier.

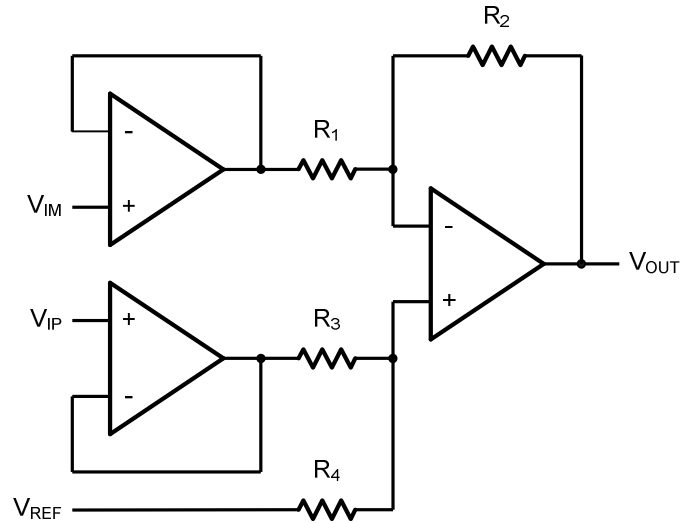

Figure 6. Instrument Amplifier

Package Information

SC70-5

Dimensions In Millimeters					
Symbol :	Min :	Max :	Symbol :	Min :	Max :
A	0.900	1.000	D	0.260	0.460
A1	0.000	0.100	Q	0°	8°
B	2.000	2.200	a	0.250 TYP	
C	2.150	2.450	b	0.650 TYP	
C1	1.150	1.350	e	1.300 TYP	

SC70-6

Dimensions In Millimeters					
Symbol :	Min :	Max :	Symbol :	Min :	Max :
A	0.900	1.000	D	0.260	0.460
A1	0.000	0.100	Q	0°	8°
B	2.000	2.200	a	0.250 TYP	
C	2.150	2.450	b	0.650 TYP	
C1	1.150	1.350			

Package Information

SOT23-5

Dimensions In Millimeters					
Symbol :	Min :	Max :	Symbol :	Min :	Max :
A	1.050	1.150	D	0.300	0.600
A1	0.000	0.100	Q	0°	8°
B	2.820	3.020	a	0.400 TYP	
C	2.650	2.950	b	0.950 TYP	
C1	1.500	1.700	e	1.900 TYP	

SOT23-6

Dimensions In Millimeters					
Symbol :	Min :	Max :	Symbol :	Min :	Max :
A	1.050	1.150	D	0.300	0.600
A1	0.000	0.100	Q	0°	8°
B	2.820	3.020	a	0.400 TYP	
C	2.650	2.950	b	0.950 TYP	
C1	1.500	1.700			

Package Information

SOP8

Dimensions In Millimeters					
Symbol :	Min :	Max :	Symbol :	Min :	Max :
A	1.225	1.570	D	0.400	0.950
A1	0.100	0.250	Q	0°	8°
B	4.800	5.100	a	0.420 TYP	
C	5.800	6.250	b	1.270 TYP	
C1	3.800	4.000			

MSOP8

Dimensions In Millimeters					
Symbol :	Min :	Max :	Symbol :	Min :	Max :
A	0.800	1.200	E1	4.700	5.100
A1	0	0.200	L1	0.410	0.650
A2	0.760	0.970	θ	0°	6°
D	2.900	3.100	b	0.300 TYP	
E	2.900	3.100	e	0.650 TYP	

Important statement:

Huaguan Semiconductor Co,Ltd. reserves the right to change the products and services provided without notice. Customers should obtain the latest relevant information before ordering, and verify the timeliness and accuracy of this information.

Customers are responsible for complying with safety standards and taking safety measures when using our products for system design and machine manufacturing to avoid potential risks that may result in personal injury or property damage.

Our products are not licensed for applications in life support, military, aerospace, etc., so we do not bear the consequences of the application of these products in these fields.

Our documentation is only permitted to be copied without any tampering with the content, so we do not accept any responsibility or liability for the altered documents.

X-ON Electronics

Largest Supplier of Electrical and Electronic Components

Click to view similar products for [Operational Amplifiers - Op Amps](#) category:

Click to view products by [HGSEMI](#) manufacturer:

Other Similar products are found below :

[430227FB](#) [UPC451G2-A](#) [UPC824G2-A](#) [LT1678IS8](#) [042225DB](#) [058184EB](#) [UPC822G2-A](#) [UPC258G2-A](#) [NCS5651MNTXG](#)
[NCV33202DMR2G](#) [NJM324E](#) [NTE925](#) [5962-9080901MCA*](#) [AZV358MTR-G1](#) [AP4310AUMTR-AG1](#) [HA1630D02MMEL-E](#)
[HA1630S01LPEL-E](#) [AZV358MMTR-G1](#) [SCY33178DR2G](#) [NJU77806F3-TE1](#) [NCV5652MUTWG](#) [NCV20034DR2G](#) [NTE778S](#) [NTE871](#)
[NTE924](#) [NTE937](#) [MCP6V16UT-E/OT](#) [MCP6V17T-E/MS](#) [MCP6V19T-E/ST](#) [SCY6358ADR2G](#) [NCS20282FCTTAG](#) [LM4565FVT-GE2](#)
[EL5420CRZ-T7A](#) [TSV772IQ2T](#) [TSV792IYST](#) [NJM2100M-TE1](#) [COS2262MR](#) [COS2252MR](#) [COS5532SRB](#) [COS2272MR](#) [LMV358MR](#)
[COS6002MR](#) [LMV358SR](#) [LM358SR](#) [RC4580MM/TR](#) [HGV8544M/TR](#) [HGV8541M/TR](#) [HGV8634M/TR](#) [HGV8542M/TR](#)
[HGV8544MT/TR](#)