

1.8MHz Zero-Drift CMOS Rail IO Opamp with

Features

- Single-Supply Operation from +1.8V ~ +5.5V
- Rail-to-Rail Input / Output
- Gain-Bandwidth Product: 1.8MHz (Typ@25°C)
- Low Input Bias Current: 20pA (Typ@25°C)
- Low Offset Voltage: 30μV (Max@25°C)
- Zero Drift: 0.01μV/°C(Typ)
- Quiescent Current: 180μA per Amplifier (Typ)
- Operating Temperature: -40°C ~ +85°C
- Embedded RF Anti-EMI Filter
- Small Package:
 HGV8551 Available in SOT23-5 and SOP-8 Packages
 HGV8552 Available in MSOP-8 and SOP-8 Packages
 HGV8554 Available in SOP-14 and TSSOP-14 Packages

General Description

The HGV855X amplifier is single/dual/quad supply, micro-power, zero-drift CMOS operational amplifiers, the amplifiers offer bandwidth of 1.8MHz, rail-to-rail inputs and outputs, and single-supply operation from 1.8V to 5.5V. HGV855X uses chopper stabilized technique to provide very low offset voltage (less than 30μV maximum) and near zero drift over temperature. Low quiescent supply current of 180μA per amplifier and very low input bias current of 20pA make the devices an ideal choice for low offset, low power consumption and high impedance applications. The HGV855X offers excellent CMRR without the crossover associated with traditional complementary input stages. This design results in superior performance for driving analog-to-digital converters (ADCs) without degradation of differential linearity.

The HGV8551 is available in SOT23-5 and SOP-8 packages. And the HGV8552 is available in MSOP-8 and SOP-8 packages. The HGV8554 Quad is available in Green SOP-14 and TSSOP-14 packages. The extended temperature range of -40°C to +85°C over all supply voltages offers additional design flexibility.

Applications

- Transducer Application
- Temperature Measurements
- Electronics Scales
- Handheld Test Equipment
- Battery-Powered Instrumentation

Pin Configuration

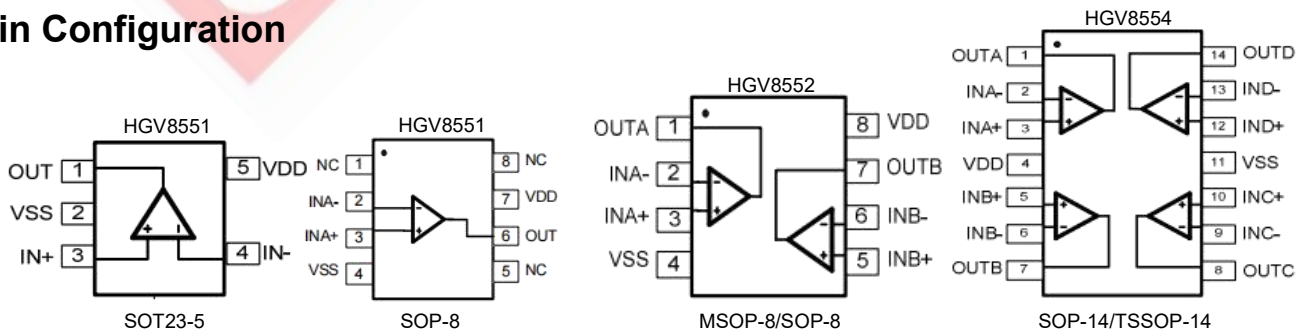

Figure 1. Pin Assignment Diagram

Absolute Maximum Rating

Condition	Min	Max
Power Supply Voltage (V _{DD} to V _{SS})	-0.5V	+7.5V
Analog Input Voltage (IN+ or IN-)	V _{SS} -0.5V	V _{DD} +0.5V
PDB Input Voltage	V _{SS} -0.5V	+7V
Operating Temperature Range	-40°C	+85°C
Junction Temperature	+160°C	
Storage Temperature Range	-55°C	+150°C
Lead Temperature (soldering, 10sec)	+260°C	
Package Thermal Resistance (T_A=+25°C)		
SOP-8, θ_{JA}	125°C/W	
MSOP-8, θ_{JA}	216°C/W	
SOT23-5, θ_{JA}	190°C/W	
ESD Susceptibility		
HBM	6KV	
MM	400V	

Note: Stress greater than those listed under Absolute Maximum Rating may cause permanent damage to the device. This is a stress rating only and functional operation of the device at these or any other conditions outside those indicated in the operational sections of this specification are not implied. Exposure to absolute maximum rating conditions for extended periods may affect reliability.

Package/Ordering Information

DEVICE	Package Type	MARKING	Packing	Packing Qty
HGV8551AIM5/TR	SOT23-5	8551	REEL	3000pcs/reel
HGV8551AIM/TR	SOP-8	V8551	REEL	2500pcs/reel
HGV8552AIM/TR	SOP-8	V8552	REEL	2500pcs/reel
HGV8552AIMM/TR	MSOP-8	V8552	REEL	3000pcs/reel
HGV8554AIMT/TR	TSSOP-14	V8554	REEL	2500pcs/reel
HGV8554AIM/TR	SOP-14	V8554	REEL	2500pcs/reel

Electrical Characteristics

(VS = +5V, VCM = +2.5V, VO = +2.5V, TA = +25°C, unless otherwise noted.)

PARAMETER	CONDITIONS	MIN	TYP	MAX	UNITS
INPUT CHARACTERISTICS					
Input Offset Voltage (VOS)			1	30	μV
Input Bias Current (IB)			20		pA
Input Offset Current (IOS)			10		pA
Common-Mode Rejection Ratio (CMRR)	VCM = 0V to 5V		110		dB
Large Signal Voltage Gain (AVO)	RL = 10kΩ, VO = 0.3V to 4.7V		145		dB
Input Offset Voltage Drift (ΔVOS/ΔT)			10	50	nV/°C
OUTPUT CHARACTERISTICS					
Output Voltage High (VOH)	RL = 100kΩ to -VS		4.998		V
	RL = 10kΩ to -VS		4.994		V
Output Voltage Low (VOL)	RL = 100kΩ to +VS		2		mV
	RL = 10kΩ to +VS		5		mV
Short Circuit Limit (ISC)	RL = 10Ω to -VS		60		mA
Output Current (IO)			65		mA
POWER SUPPLY					
Power Supply Rejection Ratio (PSRR)	VS = 2.5V to 5.5V		115		dB
Quiescent Current (IQ)	VO = 0V, RL = 0Ω		180		μA
DYNAMIC PERFORMANCE					
Gain-Bandwidth Product (GBP)	G = +100		1.8		MHz
Slew Rate (SR)	RL = 10kΩ		0.95		V/μs
Overload Recovery Time			0.10		ms
NOISE PERFORMANCE					
Voltage Noise (en p-p)	0Hz to 10Hz		0.3		μVP-P
Voltage Noise Density (en)	f = 1kHz		38		nV / Hz

Typical Performance characteristics

Large Signal Transient Response at +5

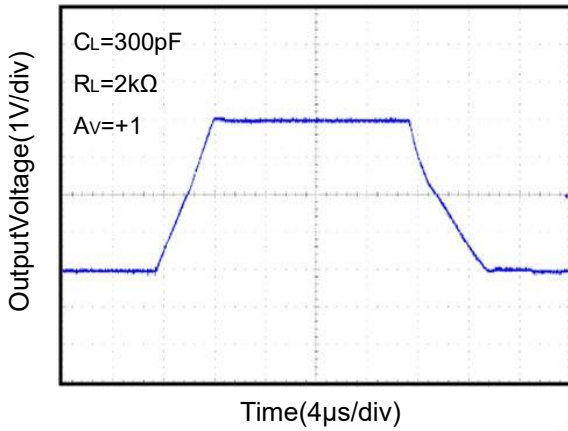

VLarge Signal Transient Response at +2.5V

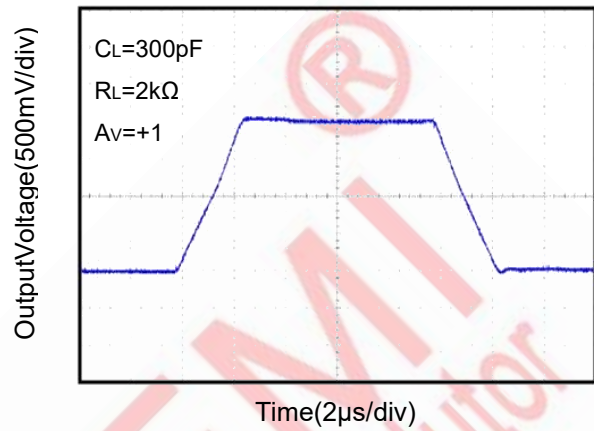

Small Signal Transient Response at +5V

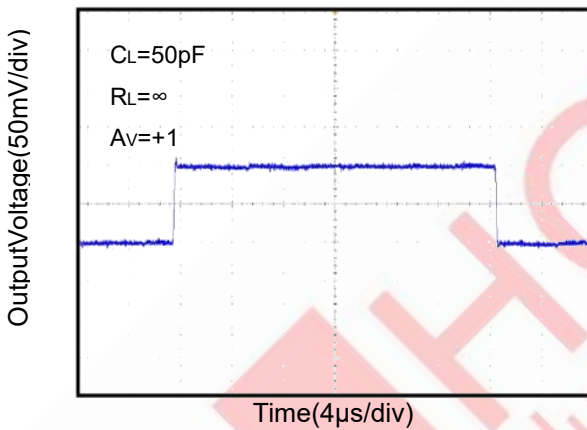

Small Signal Transient Response at +2.5V

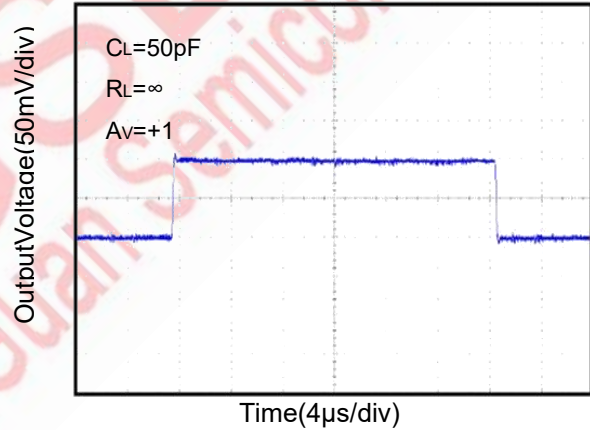

Closed Loop Gain vs. Frequency at +5V

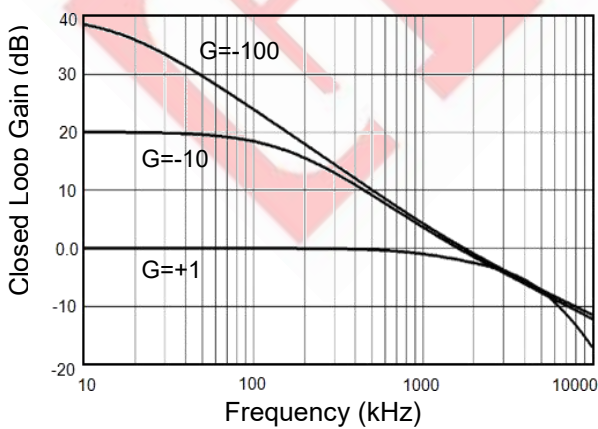

Closed Loop Gain vs. Frequency at +2.5V

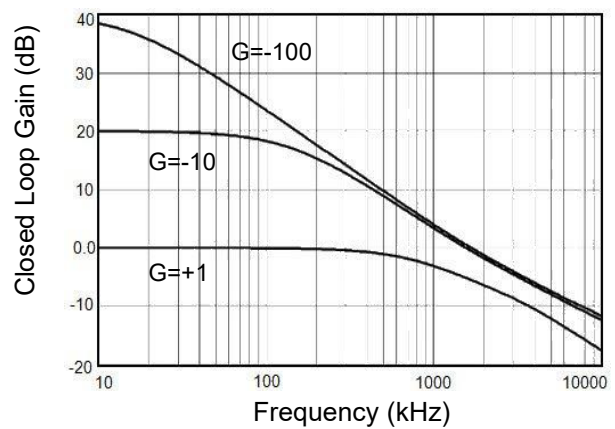

Typical Performance characteristics

Open Loop Gain, Phase Shift
vs. Frequency at +5V

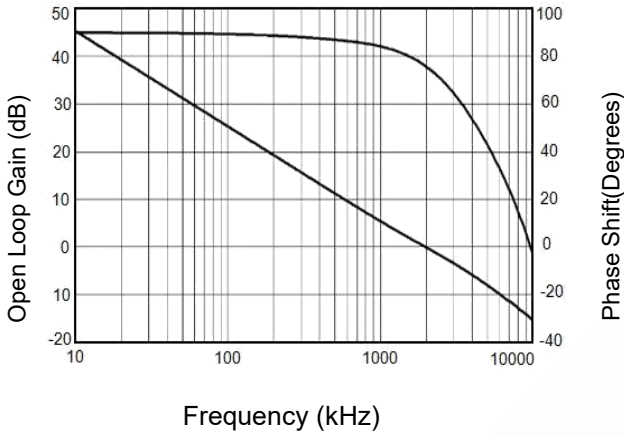

Open Loop Gain, Phase Shift
vs. Frequency at +2.5V

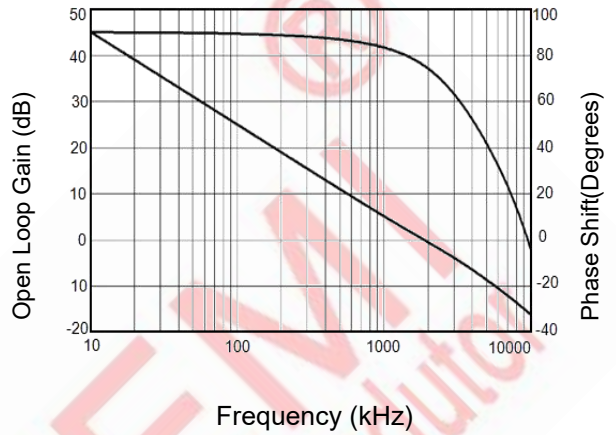

Positive Overvoltage Recovery

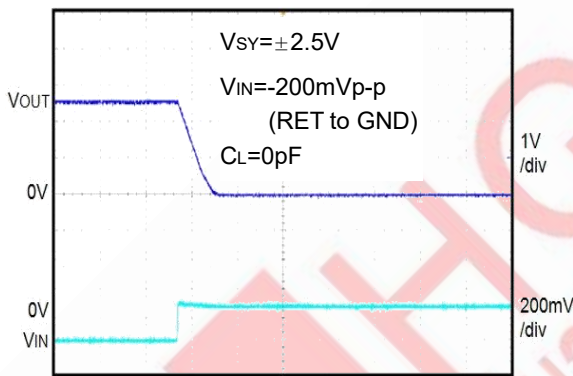

Time (40 μ s/div)

Negative Overvoltage Recovery

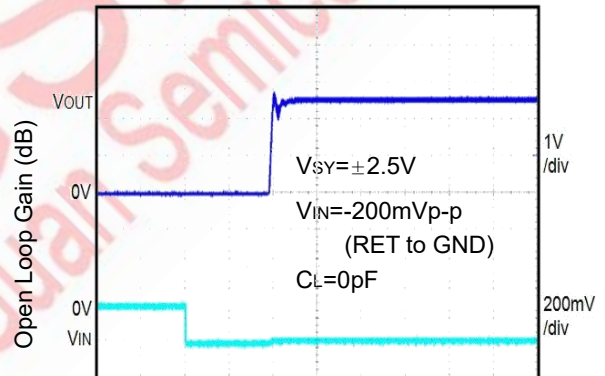

Time (40 μ s/div)

0.1Hz to 10Hz Noise at +5V

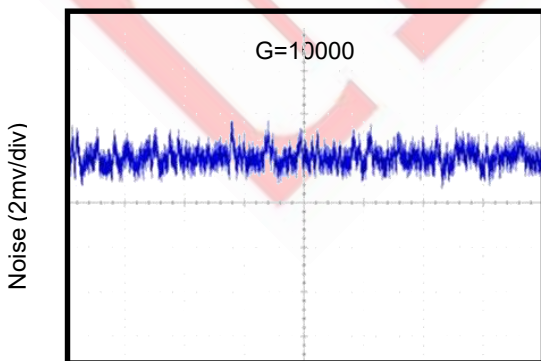

Time (10s/div)

0.1Hz to 10Hz Noise at +2.5V

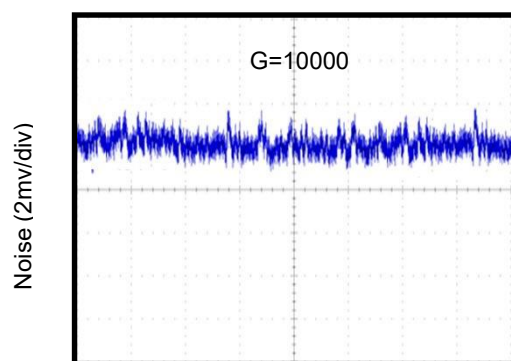

Time (10s/div)

Application Note Size

HGV855X series op amps are unity-gain stable and suitable for a wide range of general-purpose applications. The small footprints of the HGV855X series packages save space on printed circuit boards and enable the design of smaller electronic products.

Power Supply Bypassing and Board Layout

HGV855X series operates from a single 1.8V to 5.5V supply or dual $\pm 0.9V$ to $\pm 2.75V$ supplies. For best performance, a 0.1 μF ceramic capacitor should be placed close to the VDD pin in single supply operation. For dual supply operation, both VDD and VSS supplies should be bypassed to ground with separate 0.1 μF ceramic capacitors.

Low Supply Current

The low supply current (typical 180 μA per channel) of HGV855X series will help to maximize battery life. They are ideal for battery powered systems.

Operating Voltage

HGV855X series operate under wide input supply voltage (1.8V to 5.5V). In addition, all temperature specifications apply from $-40\text{ }^{\circ}C$ to $+85\text{ }^{\circ}C$. Most behavior remains unchanged throughout the full operating voltage range. These guarantees ensure operation throughout the single Li-Ion battery lifetime.

Rail-to-Rail Input

The input common-mode range of HGV855X series extends 100mV beyond the supply rails ($VSS-0.1V$ to $VDD+0.1V$). This is achieved by using complementary input stage. For normal operation, inputs should be limited to this range.

Rail-to-Rail Output

Rail-to-Rail output swing provides maximum possible dynamic range at the output. This is particularly important when operating in low supply voltages. The output voltage of HGV855X series can typically swing to less than 5mV from supply rail in light resistive loads ($>100k\Omega$), and 60mV of supply rail in moderate resistive loads (10k Ω).

Capacities Load Tolerance

The HGV855x family is optimized for bandwidth and speed, not for driving capacitive loads. Output capacitance will create a pole in the amplifier's feedback path, leading to excessive peaking and potential oscillation. If dealing with load capacitance is a requirement of the application, the two strategies to consider are (1) using a small resistor in series with the amplifier's output and the load capacitance and (2) reducing the bandwidth of the amplifier's feedback loop by increasing the overall noise gain. Figure 2. shows a unity gain follower using the series resistor strategy. The resistor isolates the output from the capacitance and, more importantly, creates a zero in the feedback path that compensates for the pole created by the output capacitance.

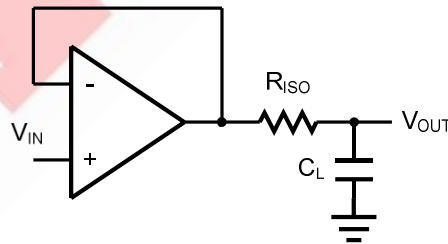

Figure 2. Indirectly Driving a Capacities Load Using Isolation Resistor

The bigger the RISO resistor value, the more stable VOUT will be. However, if there is a resistive load RL in parallel with the capacities load, a voltage divider (proportional to RISO/RL) is formed, this will result in a gain error.

The circuit in Figure 3 is an improvement to the one in Figure 2. RF provides the DC accuracy by feed-forward the VIN to RL. CF and RISO serve to counteract the loss of phase margin by feeding the high frequency component of the output signal back to the amplifier's inverting input, thereby preserving the phase margin in the overall feedback loop.

Capacities drive can be increased by increasing the value of CF. This in turn will slow down the pulse response.

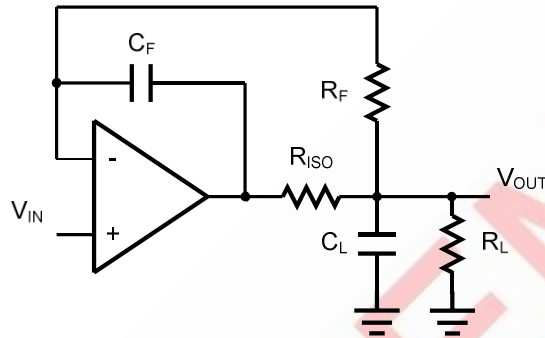

Figure 3. Indirectly Driving a Capacities Load with DC Accuracy

Typical Application Circuits

Differential amplifier

The differential amplifier allows the subtraction of two input voltages or cancellation of a signal common the two inputs. It is useful as a computational amplifier in making a differential to single-end conversion or in rejecting a common mode signal.

Figure 4. shown the differential amplifier using HGV855X.

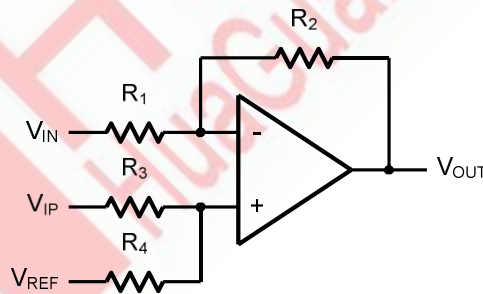

Figure 4. Differential Amplifier

$$V_{OUT} = \left(\frac{R_1+R_2}{R_3+R_4}\right) \frac{R_4}{R_1} V_{IN} - \frac{R_2}{R_1} V_{IP} + \left(\frac{R_1+R_2}{R_3+R_4}\right) \frac{R_3}{R_1} V_{REF}$$

f the resistor ratios are equal (i.e. R1=R3 and R2=R4), then

$$V_{OUT} = \frac{R_2}{R_1} (V_{IP} - V_{IN}) + V_{REF}$$

Low Pass Active Filter

The low pass active filter is shown in Figure 5. The DC gain is defined by $-R_2/R_1$. The filter has a -20dB/decade roll-off after its corner frequency $f_C=1/(2\pi R_3C_1)$.

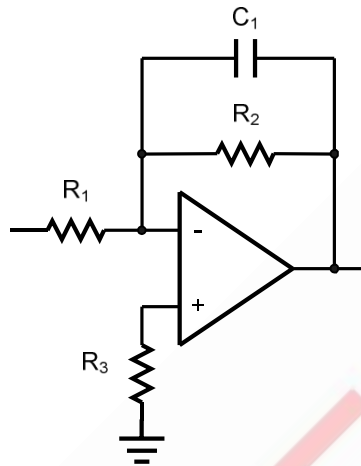

Figure 5. Low Pass Active Filter

Instrumentation Amplifier

The triple HGV855X can be used to build a three-op-amp instrumentation amplifier as shown in Figure 6. The amplifier in Figure 6 is a high input impedance differential amplifier with gain of R_2/R_1 . The two differential voltage followers assure the high input impedance of the amplifier.

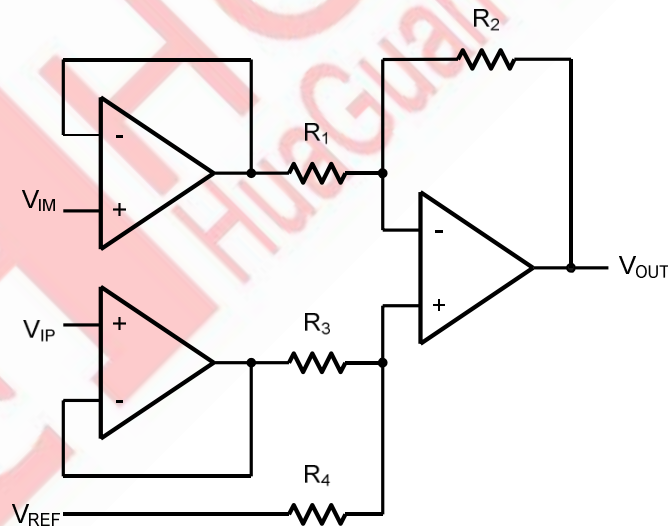
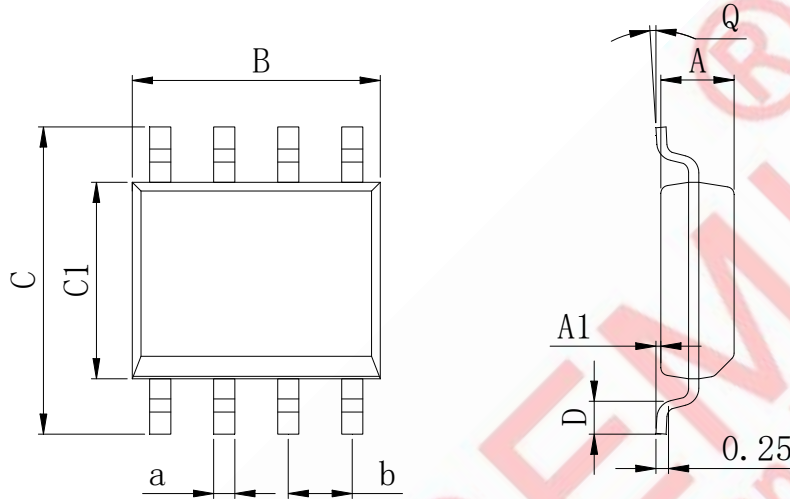

Figure 6. Instrument Amplifier

Package Information

SOP-8



Dimensions In Millimeters(SOP8L)									
Symbol:	A	A1	B	C	C1	D	Q	a	b
Min:	1.35	0.05	4.90	5.80	3.80	0.40	0	0.35	1.27 BSC
Max:	1.55	0.20	5.10	6.20	4.00	0.80	8	0.45	

MSOP-8

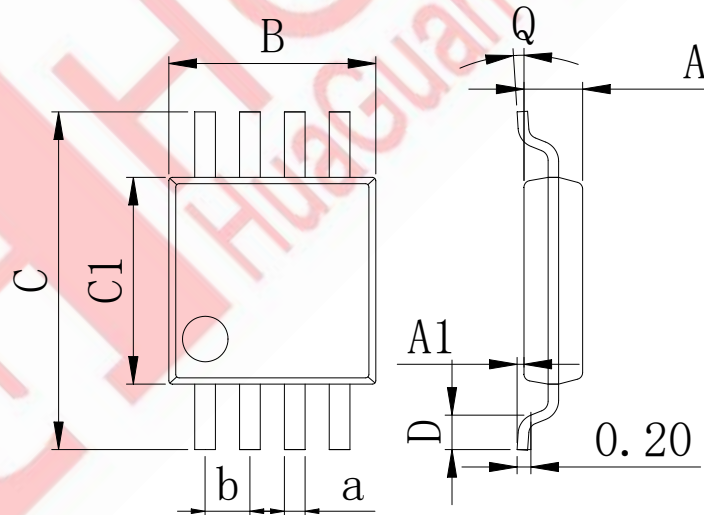

Dimensions In Millimeters(MSOP8L)									
Symbol:	A	A1	B	C	C1	D	Q	a	b
Min:	0.80	0.05	2.90	4.75	2.90	0.35	0	0.25	0.65 BSC
Max:	0.90	0.20	3.10	5.05	3.10	0.75	8	0.35	

Package Information

SOT23-5

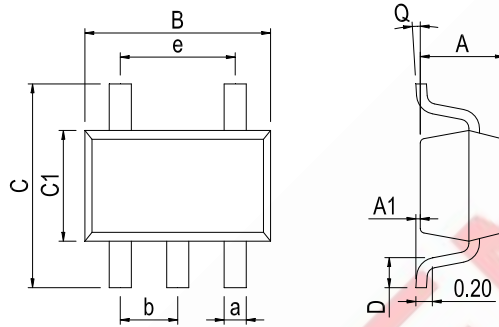

Dimensions In Millimeters(SOT23-5)

Symbol:	A	A1	B	C	C1	D	Q	a	b	e
Min:	1.05	0.00	2.82	2.65	1.50	0.30	0°	0.30	0.95 BSC	1.90 BSC
Max:	1.15	0.15	3.02	2.95	1.70	0.60	8°	0.40		

SOP-14

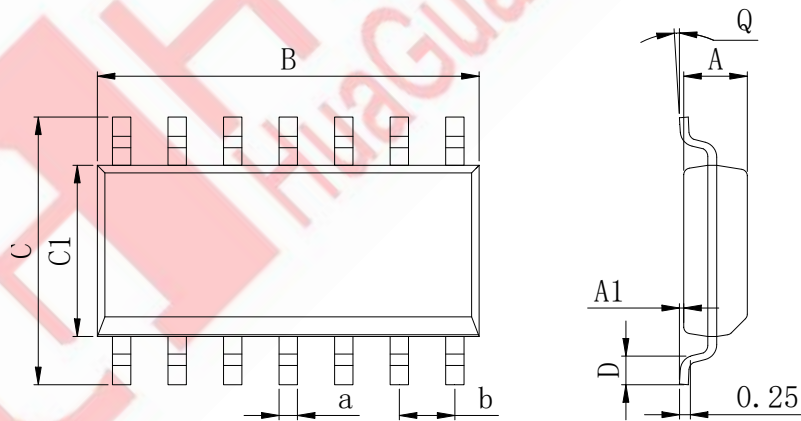

Dimensions In Millimeters(SOP14L)

Symbol:	A	A1	B	C	C1	D	Q	a	b
Min:	1.35	0.05	8.55	5.80	3.80	0.40	0	0.35	1.27 BSC
Max:	1.55	0.20	8.75	6.20	4.00	0.80	8	0.45	

TSSOP-14L

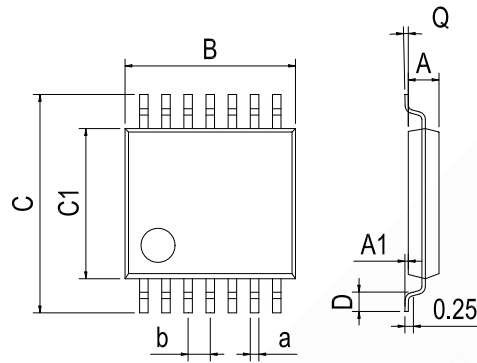

Dimensions In Millimeters(TSSOP14L)									
Symbol:	A	A1	B	C	C1	D	Q	a	b
Min:	0.85	0.05	4.90	6.20	4.30	0.40	0°	0.20	0.65 BSC
Max:	0.95	0.20	5.10	6.60	4.50	0.80	8°	0.25	

IMPORTANT STATEMENT:

Huaguan Semiconductor Co.,Ltd. reserves the right to change the products and services provided without notice. Customers should obtain the latest relevant information before ordering, and verify the timeliness and accuracy of this information.

Customers are responsible for complying with safety standards and taking safety measures when using our products for system design and machine manufacturing to avoid potential risks that may result in personal injury or property damage.

Our products are not licensed for applications in life support, military, aerospace, etc., so we do not bear the consequences of the application of these products in these fields.

Huaguan Semiconductor Co.,Ltd. the performance of the semiconductor products produced by the company can reach the performance indicators that can be applied at the time of sales. The use of testing and other quality control technologies is limited to the quality assurance scope of Huaguan semiconductor. Not all parameters of each device need to be tested. The above documents are for reference only, and all are subject to the physical parameters.

Our documentation is only permitted to be copied without any tampering with the content, so we do not accept any responsibility or liability for the altered documents.

X-ON Electronics

Largest Supplier of Electrical and Electronic Components

Click to view similar products for [Precision Amplifiers](#) category:

Click to view products by [HGSEMI](#) manufacturer:

Other Similar products are found below :

[561681F](#) [NCS20166SN2T1G](#) [NCS21802MUTBG](#) [OPA209AIDR](#) [MCP6V52-E/MS](#) [COS4333TRC](#) [COS4333SRB](#) [COS4333TRA](#)
[COS4333SRA](#) [COS1333TRD](#) [COS4333TRB](#) [COS8551TRB](#) [COS2333MRC](#) [COS27SR](#) [COS8554TRA](#) [COS2333MRB](#) [COS2333MRA](#)
[COS4227UATR](#) [HGV8541MM/TR](#) [RS8559XP](#) [HT8603ARTZ](#) [GS8538-SR](#) [OPA2335M/TR](#) [GS8548-SR](#) [HT2771BRTZ](#) [GS8552-FR](#)
[MS8551S](#) [HGV8552AIMM/TR](#) [HGV8552AIM/TR](#) [TLC27L7CP](#) [TLV2473CDR](#) [LMP2234AMA/NOPB](#) [LMP7707MA/NOPB](#)
[LMP2231AMAE/NOPB](#) [LMP2234AMTE/NOPB](#) [LMP8672MA/NOPB](#) [LMC6022IM/NOPB](#) [LMC6024IM/NOPB](#) [LMC6081IMX/NOPB](#)
[LMP2011MA/NOPB](#) [LMP2231AMFE/NOPB](#) [LMP2232BMA/NOPB](#) [LMP2234AMAE/NOPB](#) [LMP7715MFE/NOPB](#) [LMP7717MAE/NOPB](#)
[LMV2011MA/NOPB](#) [LT1013DDR](#) [TL034ACDR](#) [TLC2201AMDG4](#) [TLE2024BMDWG4](#)