

## LM2591HV SIMPLE SWITCHER® Power Converter 150-kHz, 1-A Step-Down Voltage Regulator

### Features

- 3.3-V, 5-V, and Adjustable Output Versions
- Adjustable Version Output Voltage Range: 1.2 V to 57 V  $\pm 4\%$  Maximum Over Line and Load Conditions
- Specified 1-A Output Load Current
- Available in 5-Pin Package
- Input Voltage Range Up to 60 V
- 150-kHz Fixed Frequency Internal Oscillator
- ON and OFF Control
- Low Power Standby Mode,  $I_Q$  Typically 90  $\mu$ A
- High Efficiency
- Thermal Shutdown and Current-Limit Protection

### Applications

- Simple High-Efficiency Step-Down (Buck) Regulators
- Efficient Preregulator for Linear Regulators
- On-Card Switching Regulators
- Positive-to-Negative Converters

### Description

The LM2591HV series of regulators are monolithic integrated circuits that provide all the active functions for a step-down (buck) switching regulator, capable of driving a 1-A load with excellent line and load regulation. These devices are available in fixed output voltages of 3.3 V, 5 V, and an adjustable output version.

This series of switching regulators is similar to the LM2590HV, but without some of the supervisory and control features of the latter.

Requiring a minimum number of external components, these regulators are simple to use and include internal frequency compensation, improved line and load specifications, and a fixed-frequency oscillator.

The LM2591HV operates at a switching frequency of 150 kHz, thus allowing smaller sized filter components than what would be needed with lower frequency switching regulators. Available in a standard 5-pin package with several different lead bend options, and a 5-pin surface mount package.

### Device Information<sup>(1)</sup>

PART NUMBER	PACKAGE	BODY SIZE (NOM)
LM2591HV	DDPAK/TO-263 (5)	10.18 mm x 8.41 mm
	TO-220 (5)	14.986 mm x 10.16 mm

(1) For all available packages, see the orderable addendum at the end of the data sheet.

### Typical Application

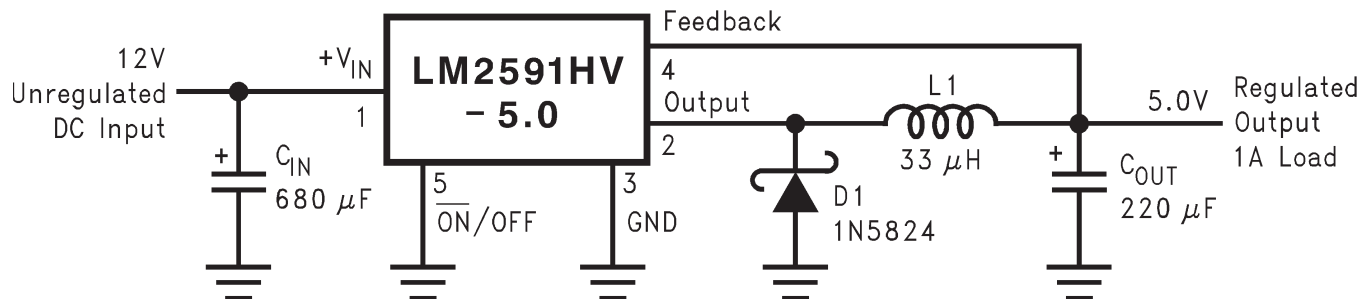

Copyright © 2016, Texas Instruments Incorporated

(Fixed Output Voltage Versions)

## Description (continued)

Other features include a specified  $\pm 4\%$  tolerance on output voltage under all conditions of input voltage and output load conditions, and  $\pm 15\%$  on the oscillator frequency. External shutdown is included, featuring typically 90- $\mu\text{A}$  standby current. Self-protection features include a two stage current limit for the output switch and an over temperature shutdown for complete protection under fault conditions.

## Pin Configuration and Functions

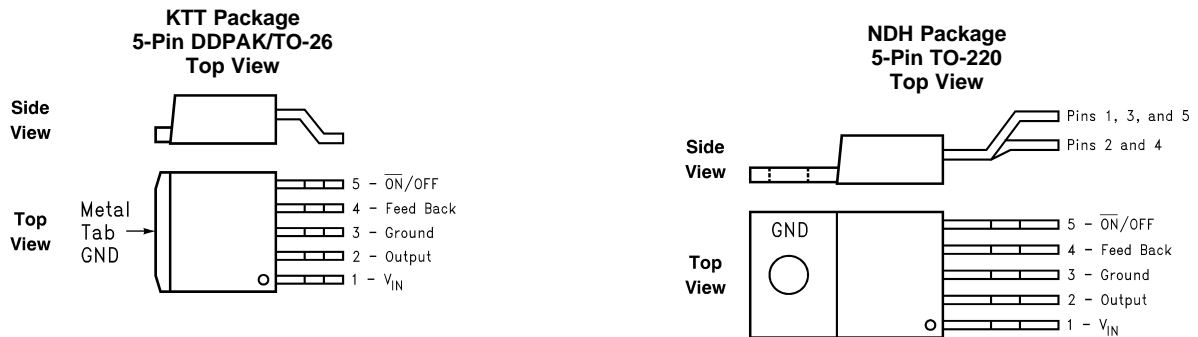

### Pin Functions

PIN		I/O	DESCRIPTION
NO.	NAME		
1	$+V_{IN}$	I	This is the positive input supply for the IC switching regulator. A suitable input bypass capacitor must be present at this pin to minimize voltage transients and to supply the switching currents needed by the regulator.
2	Output	O	Internal switch. The voltage at this pin switches between approximately $(+V_{IN} - V_{SAT})$ and approximately $-0.5\text{ V}$ , with a duty cycle of $V_{OUT}/V_{IN}$ .
3	Ground	—	Circuit ground.
4	Feedback	I	Senses the regulated output voltage to complete the feedback loop. This pin is directly connected to the Output for the fixed voltage versions, but is set to 1.23 V by means of a resistive divider from the output for the Adjustable version. If a feedforward capacitor is used (Adjustable version), then a negative voltage spike is generated on this pin whenever the output is shorted. This happens because the feedforward capacitor cannot discharge fast enough, and because one end of it is dragged to Ground, the other end goes momentarily negative. To prevent the energy rating of this pin from being exceeded, a small-signal Schottky diode to Ground is recommended for DC input voltages above 40 V whenever a feedforward capacitor is present (See <a href="#">Test Circuits</a> ). Feedforward capacitor values larger than 0.1 $\mu\text{F}$ are not recommended for the same reason, whatever be the DC input voltage.
5	$\overline{\text{ON}}/\text{OFF}$	I	The regulator is in shutdown mode, drawing about 90 $\mu\text{A}$ , when this pin is driven to a high level ( $\geq 2\text{ V}$ ), and is in normal operation when this Pin is left floating or driven to a low level ( $\leq 0.6\text{ V}$ ). The typical value of the threshold is 1.3 V and the voltage on this pin must not exceed 25 V.

## Specifications

### Absolute Maximum Ratings<sup>(1)(2)</sup>

		MIN	MAX	UNIT
Maximum supply voltage (V <sub>IN</sub> )			63	V
ON/OFF pin voltage		-0.3	25	V
Feedback pin voltage		-0.3	25	V
Output voltage to ground	(Steady-state)		-1	V
Power dissipation		Internally limited		
Lead temperature	KTT package	Vapor phase (60 sec.)		°C
		Infrared (10 sec.)		
	NDH package (Soldering, 10 sec.)		260	
Maximum junction temperature			150	°C
Storage temperature, T <sub>stg</sub>		-65	150	°C

- (1) Stresses beyond those listed under *Absolute Maximum Ratings* may cause permanent damage to the device. These are stress ratings only, which do not imply functional operation of the device at these or any other conditions beyond those indicated under *Recommended Operating Conditions*. Exposure to absolute-maximum-rated conditions for extended periods may affect device reliability.
- (2) If Military/Aerospace specified devices are required, please contact the TI Sales Office/ Distributors for availability and specifications.

### ESD Ratings

		VALUE	UNIT
V <sub>(ESD)</sub>	Electrostatic discharge	Human-body model (HBM), per ANSI/ESDA/JEDEC JS-001 <sup>(1)(2)</sup>	±2000 V

- (1) JEDEC document JEP155 states that 500-V HBM allows safe manufacturing with a standard ESD control process.
- (2) The human body model is a 100-pF capacitor discharged through a 1.5-kΩ resistor into each pin.

		MIN	MAX	UNIT
Temperature		-40	125	°C
Supply voltage		4.5	60	V

### Thermal Information

THERMAL METRIC <sup>(1)</sup>			LM2591HV		UNIT
			KTT (DDPAK/TO-263)	NDH (TO-220)	
			5 PINS	5 PINS	
R <sub>θJA</sub>	Junction-to-ambient thermal resistance	See <sup>(2)(3)</sup>	50	50	°C/W
R <sub>θJC(top)</sub>	Junction-to-case (top) thermal resistance		2	2	°C/W

- (1) For more information about traditional and new thermal metrics, see the *Semiconductor and IC Package Thermal Metrics* application report, [SPRA953](#).
- (2) The package thermal impedance is calculated in accordance to JESD 51-7
- (3) Thermal Resistances were simulated on a 4-layer, JEDEC board

### Electrical Characteristics LM2591HV-3.3

Specifications are for  $T_J = 25^\circ\text{C}$  unless otherwise noted.

PARAMETER		TEST CONDITIONS	MIN <sup>(1)</sup>	TYP <sup>(2)</sup>	MAX <sup>(1)</sup>	UNIT	
<b>SYSTEM PARAMETERS – See <a href="#">Test Circuits</a><sup>(3)</sup></b>							
$V_{OUT}$	Output Voltage	4.75 V $\leq V_{IN} \leq 60$ V, 0.2 A $\leq I_{LOAD} \leq 1$ A		3.168	3.3	3.432	V
			$T_A = -40^\circ\text{C}$ to $125^\circ\text{C}$	3.135		3.465	
$\eta$	Efficiency	$V_{IN} = 12$ V, $I_{LOAD} = 1$ A		77%			

- (1) All limits ensured at room temperature ( $T_J = 25^\circ\text{C}$ ) unless otherwise noted. All room temperature limits are 100% production tested. All limits at temperature extremes are ensured through correlation using standard Statistical Quality Control (SQC) methods. All limits are used to calculate Average Outgoing Quality Level (AOQL).
- (2) Typical numbers are at  $25^\circ\text{C}$  and represent the most likely norm.
- (3) External components such as the catch diode, inductor, input and output capacitors can affect switching regulator system performance. When the LM2591HV is used as shown in [Test Circuits](#) test circuit, system performance will be as shown in [Electrical Characteristics](#).

### Electrical Characteristics LM2591HV-5.0

Specifications are for  $T_J = 25^\circ\text{C}$  unless otherwise noted.

PARAMETER		TEST CONDITIONS	MIN <sup>(1)</sup>	TYP <sup>(2)</sup>	MAX <sup>(1)</sup>	UNIT	
<b>SYSTEM PARAMETERS – See <a href="#">Test Circuits</a><sup>(3)</sup></b>							
$V_{OUT}$	Output Voltage	7 V $\leq V_{IN} \leq 60$ V, 0.2 A $\leq I_{LOAD} \leq 1$ A		4.8	5	5.2	V
			$T_A = -40^\circ\text{C}$ to $125^\circ\text{C}$	4.75		5.25	
$\eta$	Efficiency	$V_{IN} = 12$ V, $I_{LOAD} = 1$ A		82%			

- (1) All limits ensured at room temperature ( $T_J = 25^\circ\text{C}$ ) unless otherwise noted. All room temperature limits are 100% production tested. All limits at temperature extremes are ensured through correlation using standard Statistical Quality Control (SQC) methods. All limits are used to calculate Average Outgoing Quality Level (AOQL).
- (2) Typical numbers are at  $25^\circ\text{C}$  and represent the most likely norm.
- (3) External components such as the catch diode, inductor, input and output capacitors can affect switching regulator system performance. When the LM2591HV is used as shown in [Test Circuits](#) test circuit, system performance will be as shown in [Electrical Characteristics](#).

### Electrical Characteristics LM2591HV-ADJ

Specifications are for  $T_J = 25^\circ\text{C}$  unless otherwise noted.

PARAMETER		TEST CONDITIONS	MIN <sup>(1)</sup>	TYP <sup>(2)</sup>	MAX <sup>(1)</sup>	UNIT	
<b>SYSTEM PARAMETERS – See <a href="#">Test Circuits</a><sup>(3)</sup></b>							
$V_{FB}$	Feedback Voltage	4.5 V $\leq V_{IN} \leq 60$ V, 0.2 A $\leq I_{LOAD} \leq 1$ A $V_{OUT}$ programmed for 3 V. Circuit of <a href="#">Test Circuits</a> .		1.193	1.23	1.267	V
			$T_A = -40^\circ\text{C}$ to $125^\circ\text{C}$	1.18		1.28	
$\eta$	Efficiency	$V_{IN} = 12$ V, $V_{OUT} = 3$ V, $I_{LOAD} = 1$ A		76%			

- (1) All limits ensured at room temperature ( $T_J = 25^\circ\text{C}$ ) unless otherwise noted. All room temperature limits are 100% production tested. All limits at temperature extremes are ensured through correlation using standard Statistical Quality Control (SQC) methods. All limits are used to calculate Average Outgoing Quality Level (AOQL).
- (2) Typical numbers are at  $25^\circ\text{C}$  and represent the most likely norm.
- (3) External components such as the catch diode, inductor, input and output capacitors can affect switching regulator system performance. When the LM2591HV is used as shown in [Test Circuits](#) test circuit, system performance will be as shown in [Electrical Characteristics](#).

**Electrical Characteristics All Output Voltage Versions**

Specifications are for  $T_J = 25^\circ\text{C}$ ,  $I_{\text{LOAD}} = 500\text{ mA}$ , and  $V_{\text{IN}} = 12\text{ V}$  for the 3.3-V, 5-V, and adjustable versions, unless otherwise noted.

PARAMETER		TEST CONDITIONS	MIN <sup>(1)</sup>	TYP <sup>(2)</sup>	MAX <sup>(1)</sup>	UNIT	
<b>DEVICE PARAMETERS</b>							
$I_b$	Feedback Bias Current	Adjustable Version Only, $V_{\text{FB}} = 1.3\text{ V}$		10	50	nA	
			$T_A = -40^\circ\text{C}$ to $125^\circ\text{C}$		100		
$f_o$	Oscillator Frequency	See <sup>(3)</sup>		127	150	173	kHz
			$T_A = -40^\circ\text{C}$ to $125^\circ\text{C}$	110		173	
$V_{\text{SAT}}$	Saturation Voltage	$I_{\text{OUT}} = 1\text{ A}$ <sup>(4)(5)</sup>		0.95	1.2	V	
			$T_A = -40^\circ\text{C}$ to $125^\circ\text{C}$				1.3
DC	Max Duty Cycle (ON)	See <sup>(5)(6)</sup>		100%			
	Min Duty Cycle (OFF)			0%			
$I_{\text{CLIM}}$	Switch current Limit	Peak Current <sup>(4)(5)</sup>		1.3	1.9	2.8	A
			$T_A = -40^\circ\text{C}$ to $125^\circ\text{C}$	1.2		3.0	
$I_L$	Output Leakage Current	Output = 0 V		5	50	$\mu\text{A}$	
		Output = -1 V <sup>(4)(6)(7)</sup>		5	30	mA	
$I_Q$	Operating Quiescent Current	$\overline{\text{SD}}/\overline{\text{SS}}$ Pin Open <sup>(6)</sup>		5	10	mA	
$I_{\text{STBY}}$	Standby Quiescent Current	$\overline{\text{SD}}/\overline{\text{SS}}$ pin = 0 V <sup>(7)</sup>		90	200	$\mu\text{A}$	
			$T_A = -40^\circ\text{C}$ to $125^\circ\text{C}$				250
<b>ON/OFF CONTROL – See <i>Test Circuits</i></b>							
$V_{\text{IH}}$ $V_{\text{IL}}$	$\overline{\text{ON}}/\overline{\text{OFF}}$ Pin Logic Input Threshold Voltage	Low (Regulator ON)		1.3		V	
		High (Regulator OFF)	$T_A = -40^\circ\text{C}$ to $125^\circ\text{C}$	2.0	0.6		
$I_{\text{H}}$	$\overline{\text{ON}}/\overline{\text{OFF}}$ Pin Input Current	$V_{\text{LOGIC}} = 2.5\text{ V}$ (Regulator OFF)		5	15	$\mu\text{A}$	
$I_{\text{L}}$		$V_{\text{LOGIC}} = 0.5\text{ V}$ (Regulator ON)		0.02	5	$\mu\text{A}$	

- (1) All limits ensured at room temperature ( $T_J = 25^\circ\text{C}$ ) unless otherwise noted. All room temperature limits are 100% production tested. All limits at temperature extremes are ensured through correlation using standard Statistical Quality Control (SQC) methods. All limits are used to calculate Average Outgoing Quality Level (AOQL).
- (2) Typical numbers are at  $25^\circ\text{C}$  and represent the most likely norm.
- (3) The switching frequency is reduced when the second stage current limit is activated. The amount of reduction is determined by the severity of current overload.
- (4) No diode, inductor or capacitor connected to output pin.
- (5) Feedback pin removed from output and connected to 0 V to force the output transistor switch ON.
- (6) Feedback pin removed from output and connected to 12 V for the 3.3-V, 5-V, and the ADJ. version to force the output transistor switch OFF.
- (7)  $V_{\text{IN}} = 60\text{ V}$ .

**Typical Characteristics**

(Circuit of *Test Circuits*)

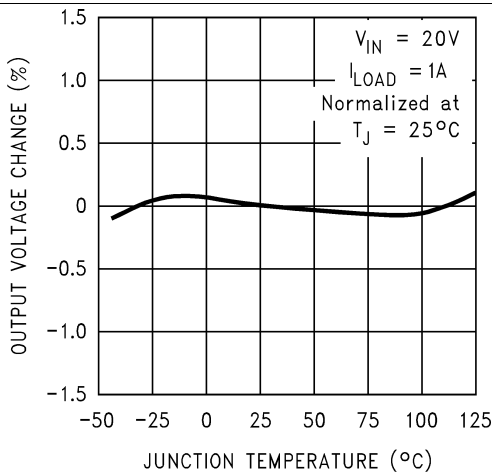

**Figure 1. Normalized Output Voltage**

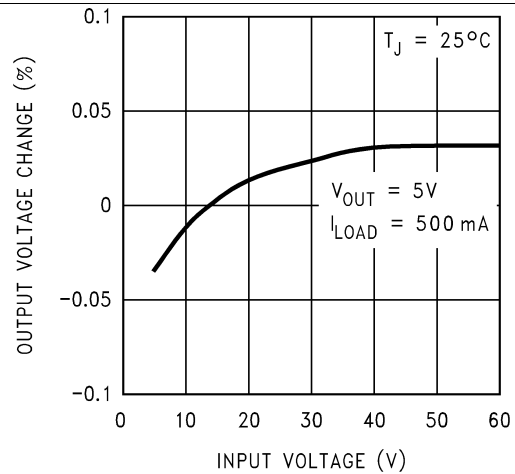

**Figure 2. Line Regulation**

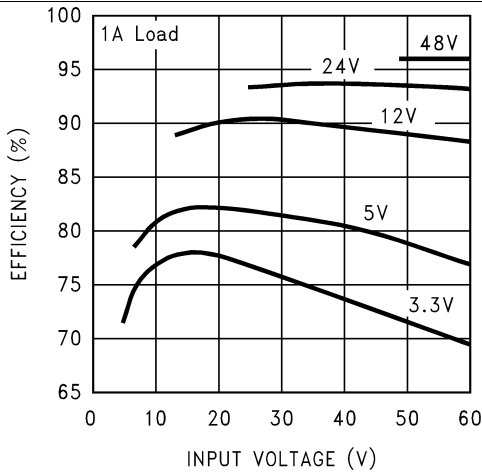

**Figure 3. Efficiency**

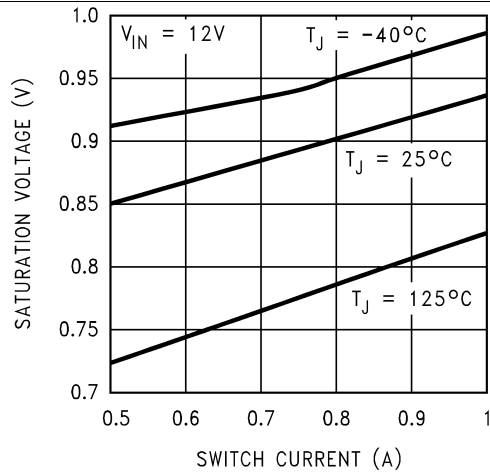

**Figure 4. Switch Saturation Voltage**

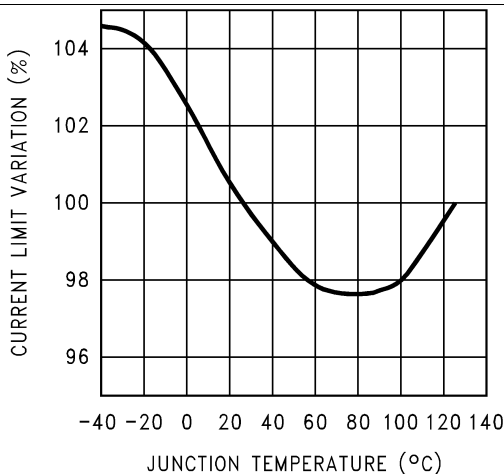

**Figure 5. Switch Current Limit**

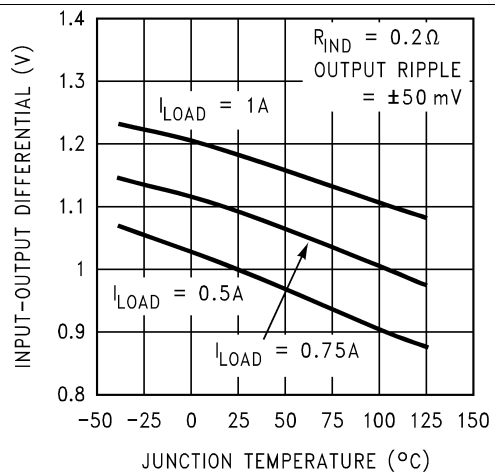

**Figure 6. Dropout Voltage**

Typical Characteristics (continued)

(Circuit of *Test Circuits*)

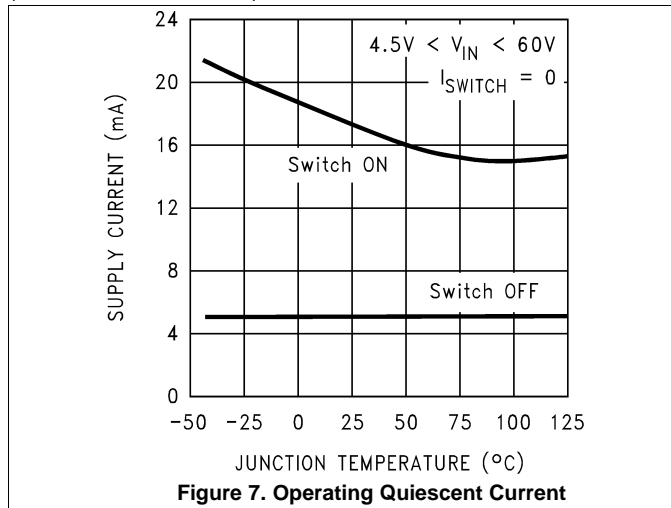

Figure 7. Operating Quiescent Current

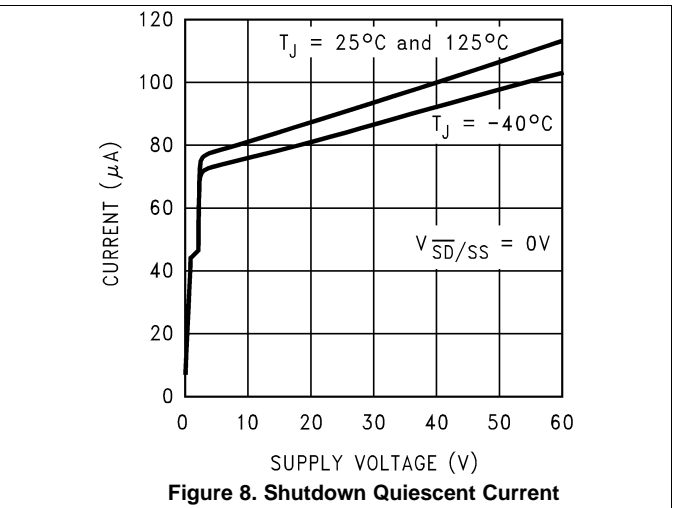

Figure 8. Shutdown Quiescent Current

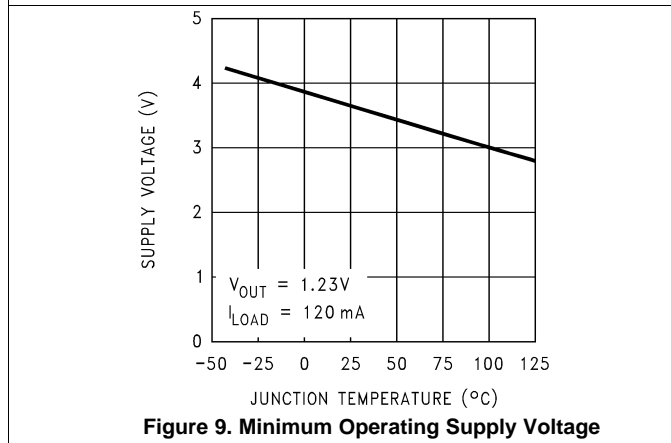

Figure 9. Minimum Operating Supply Voltage

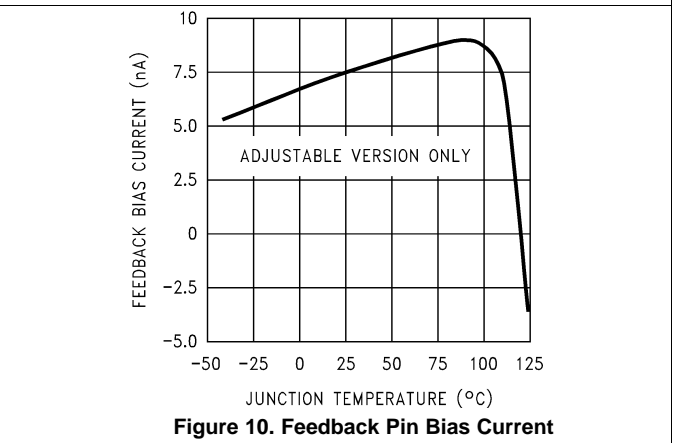

Figure 10. Feedback Pin Bias Current

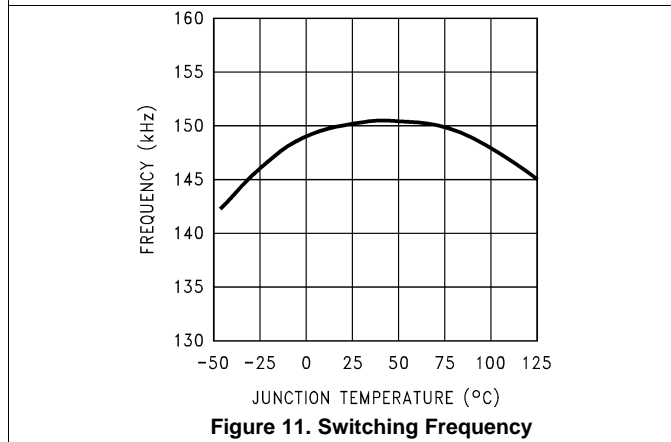

Figure 11. Switching Frequency

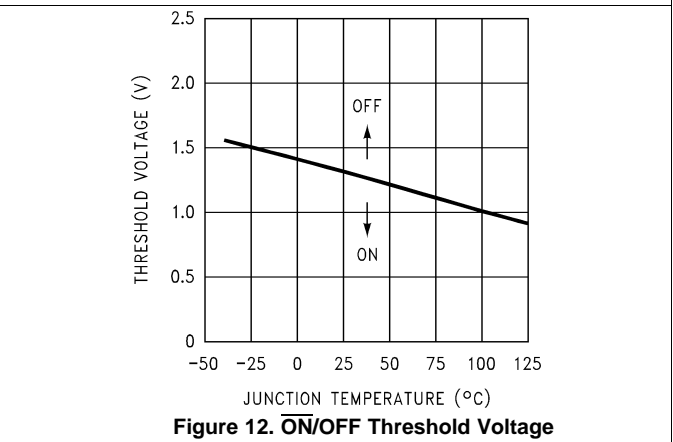
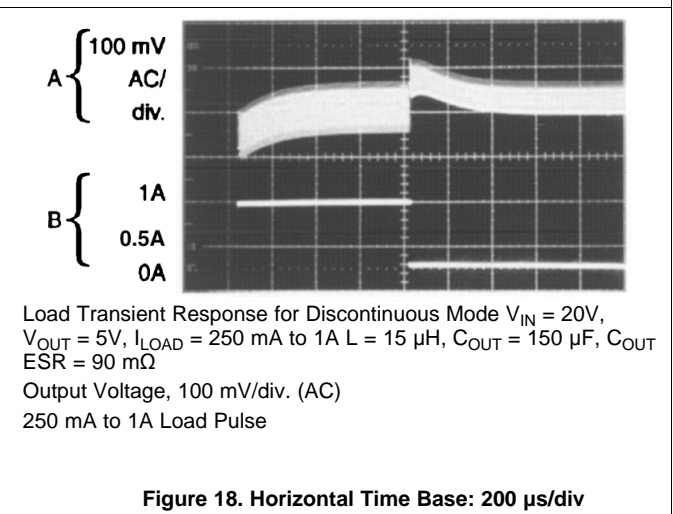
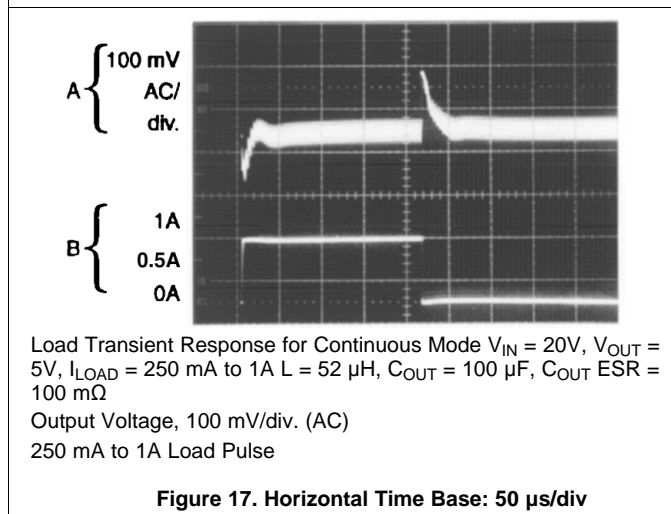
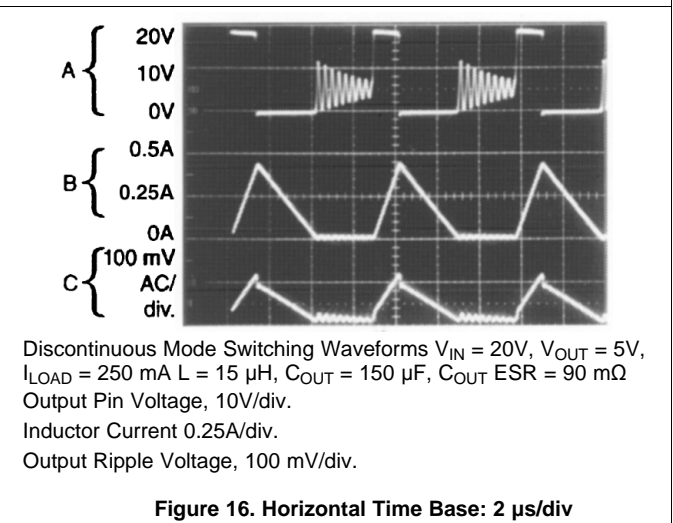
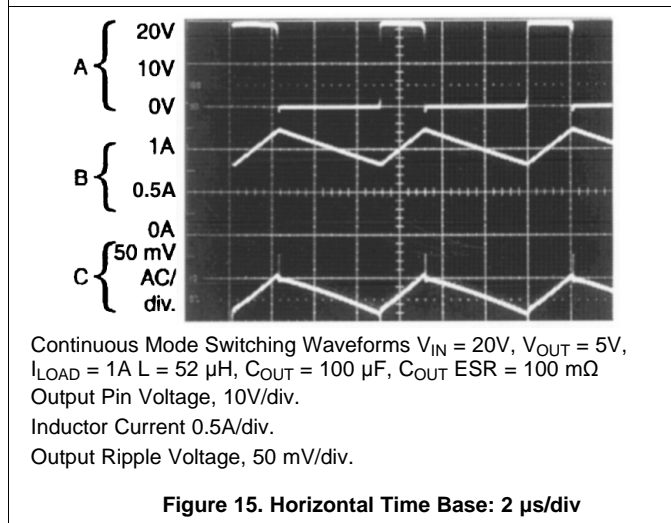
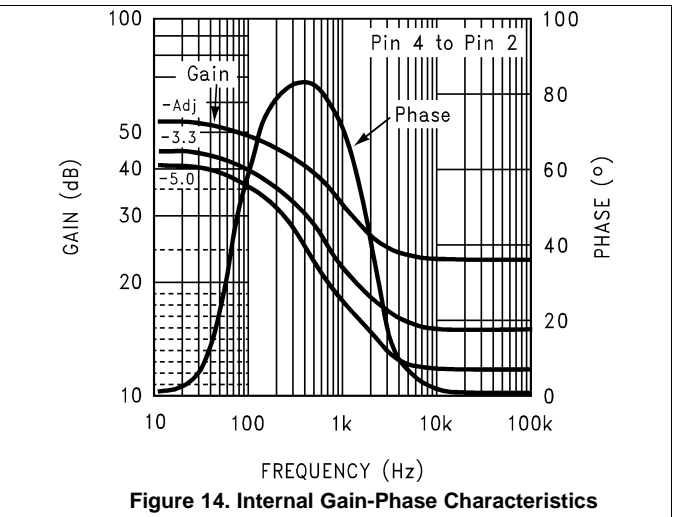
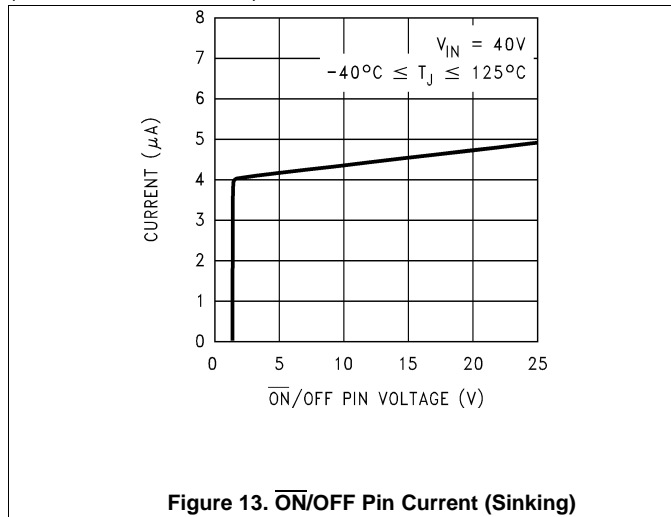

Figure 12. ON/OFF Threshold Voltage

**Typical Characteristics (continued)**

(Circuit of [Test Circuits](#))





## Parameter Measurement Information

### Test Circuits

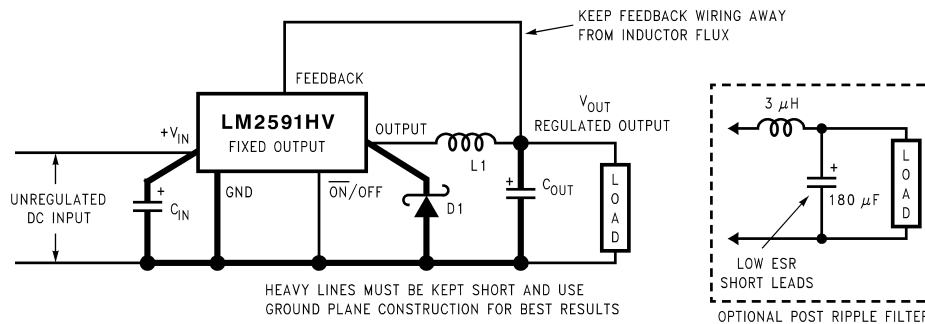

Component Values shown are for  $V_{IN} = 15V$ ,

$V_{OUT} = 5V$ ,  $I_{LOAD} = 1A$ .

$C_{IN}$  — 470  $\mu F$ , 50V, Aluminum Electrolytic Nichicon "PM Series"

$C_{OUT}$  — 220  $\mu F$ , 25V Aluminum Electrolytic, Nichicon "PM Series"

D1 — 2A, 60V Schottky Rectifier, 21DQ06 (International Rectifier)

L1 — 68 H, See [Inductor Selection Procedure](#)

**Figure 19. Fixed Output Voltage Versions**

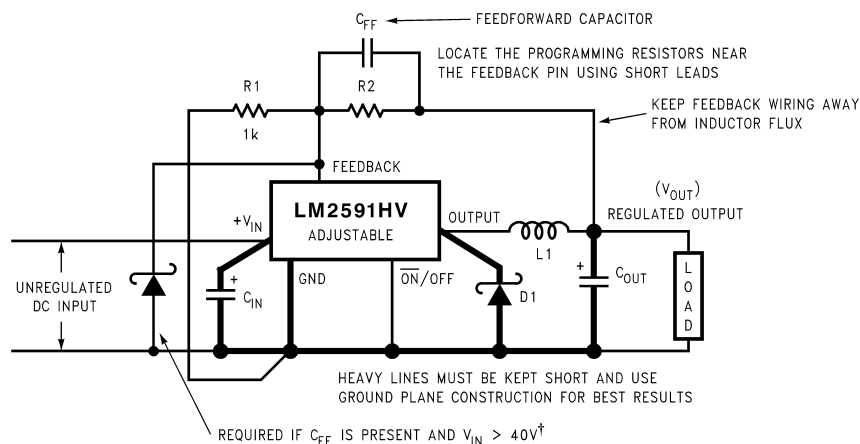

Select  $R_1$  to be approximately 1 k $\Omega$ , use a 1% resistor for best stability.

Component Values shown are for  $V_{IN} = 20V$ ,

$V_{OUT} = 10V$ ,  $I_{LOAD} = 1A$ .

$C_{IN}$ : — 470  $\mu F$ , 35V, Aluminum Electrolytic Nichicon "PM Series"

$C_{OUT}$ : — 220  $\mu F$ , 35V Aluminum Electrolytic, Nichicon "PM Series"

D1 — 2A, 60V Schottky Rectifier, 21DQ06 (International Rectifier)

See [Inductor Selection Procedure](#) L1 — 100  $\mu H$ ,

$R_1$  — 1 k $\Omega$ , 1%

$R_2$  — 7.15k, 1%

$C_{FF}$  — 3.3 nF

*Typical Values*

$C_{SS}$ —0.1  $\mu F$

$C_{DELAY}$ —0.1  $\mu F$

$R_{PULL UP}$  — 4.7k (use 22k if  $V_{OUT}$  is  $\geq 45V$ )

† Small signal Schottky diode to prevent damage to feedback pin by negative spike when output is shorted. Required if  $V_{IN} > 40V$

**Figure 20. Adjustable Output Voltage Versions**

## Detailed Description

### Overview

The LM2591HV SIMPLE SWITCHER® regulator is an easy-to-use, nonsynchronous, step-down DC-DC converter with a wide input voltage range up to 60 V. The regulator is capable of delivering up to 1-A DC load current with excellent line and load regulation. These devices are available in fixed output voltages of 3.3 V, 5 V, and an adjustable output version. The family requires few external components, and the pin arrangement was designed for simple, optimum PCB layout.

### Functional Block Diagram

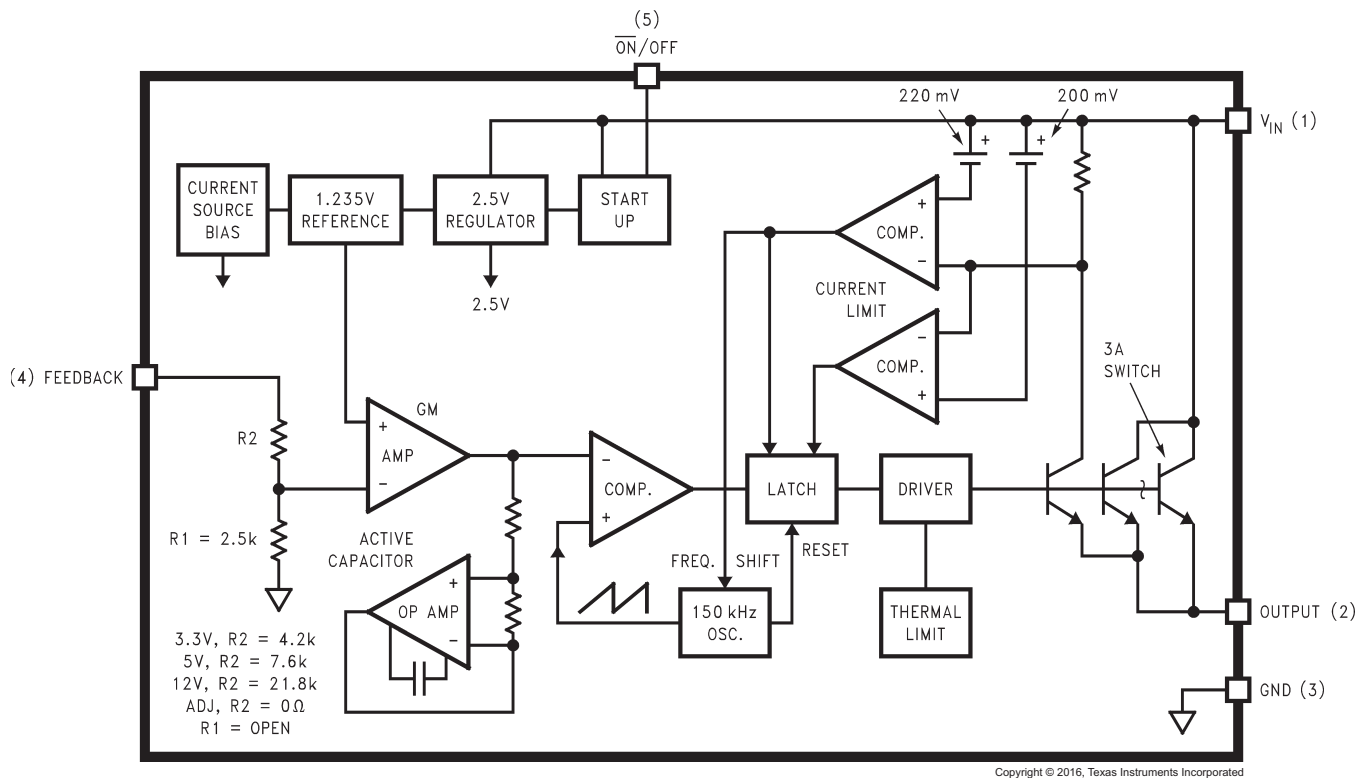

### Feature Description

#### Delayed Start-Up

The circuit in Figure 21 uses the  $\overline{\text{ON/OFF}}$  pin to provide a time delay between the time the input voltage is applied and the time the output voltage comes up (only the circuitry pertaining to the delayed start-up is shown). As the input voltage rises, the charging of capacitor C1 pulls the  $\overline{\text{ON/OFF}}$  pin high, keeping the regulator off. When the input voltage reaches its final value and the capacitor stops charging, the resistor R<sub>2</sub> pulls the  $\overline{\text{ON/OFF}}$  pin low, thus allowing the circuit to start switching. Resistor R<sub>1</sub> is included to limit the maximum voltage applied to the  $\overline{\text{ON/OFF}}$  pin (maximum of 25 V), reduces power supply noise sensitivity, and also limits the capacitor, C1, discharge current. When high input ripple voltage exists, avoid long delay time, because this ripple can be coupled into the  $\overline{\text{ON/OFF}}$  pin and cause problems.

This delayed start-up feature is useful in situations where the input power source is limited in the amount of current it can deliver. It allows the input voltage to rise to a higher voltage before the regulator starts operating. Buck regulators require less input current at higher input voltages.

Feature Description (continued)

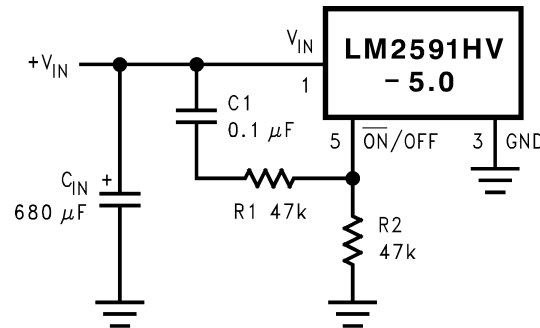

Figure 21. Delayed Start-Up

Undervoltage Lockout

Some applications require the regulator to remain off until the input voltage reaches a predetermined voltage. An undervoltage lockout feature applied to a buck regulator is shown in Figure 22, while Figure 23 and Figure 24 applies the same feature to an inverting circuit. The circuit in Figure 23 features a constant threshold voltage for turnon and turnoff (Zener voltage plus approximately one volt). If hysteresis is needed, the circuit in Figure 24 has a turnon voltage which is different than the turnoff voltage. The amount of hysteresis is approximately equal to the value of the output voltage. If Zener voltages greater than 25 V are used, an additional 47-kΩ resistor is needed from the ON/OFF pin to the ground pin to stay within the 25-V maximum limit of the ON/OFF pin.

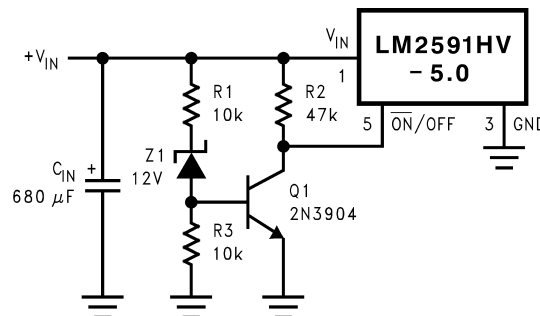
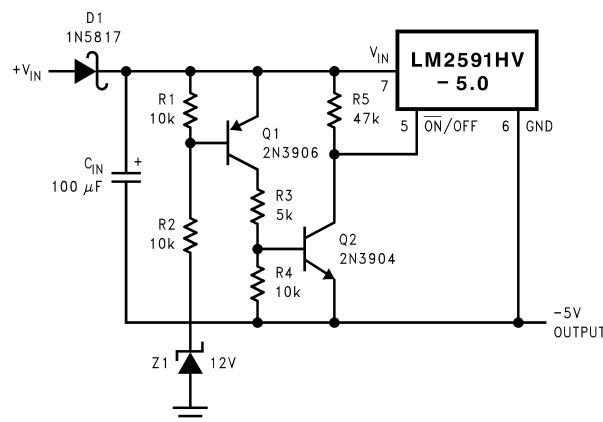

Figure 22. Undervoltage Lockout for Buck Regulator



This circuit has an ON/OFF threshold of approximately 13 V.

Figure 23. Undervoltage Lockout for Inverting Regulator

## Device Functional Modes

### Shutdown Mode

The  $\overline{\text{ON}}/\text{OFF}$  pin provides electrical ON and OFF control for the LM2591HV. When the voltage of this pin is higher than 2 V, the device is shutdown mode. The typical standby current in this mode is 90  $\mu\text{A}$ .

### Active Mode

When the  $\overline{\text{ON}}/\text{OFF}$  pin is left floating or pull below 0.6 V, the device starts switching and the output voltage rises until it reaches a normal regulation voltage.

---

## Application and Implementation

---

### NOTE

Information in the following applications sections is not part of the HG component specification, and TI does not warrant its accuracy or completeness. TI's customers are responsible for determining suitability of components for their purposes. Customers should validate and test their design implementation to confirm system functionality.

---

## Application Information

### Feedforward Capacitor

$C_{FF}$  – A feedforward capacitor, shown across R2 in [Test Circuits](#), is used when the output voltage is greater than 10 V or when  $C_{OUT}$  has a very low ESR. This capacitor adds lead compensation to the feedback loop and increases the phase margin for better loop stability.

If the output voltage ripple is large (>5% of the nominal output voltage), this ripple can be coupled to the feedback pin through the feedforward capacitor and cause the error comparator to trigger the error flag. In this situation, adding a resistor,  $R_{FF}$ , in series with the feedforward capacitor, approximately 3 times R1, will attenuate the ripple voltage at the feedback pin.

### Input Capacitor

$C_{IN}$  – A low ESR aluminum or tantalum bypass capacitor is needed between the input pin and ground pin. It must be placed near the regulator using short leads. This capacitor prevents large voltage transients from appearing at the input, and provides the instantaneous current needed each time the switch turns on.

The important parameters for the Input capacitor are the voltage rating and the RMS current rating. Because of the relatively high RMS currents flowing in a buck regulator's input capacitor, this capacitor should be chosen for its RMS current rating rather than its capacitance or voltage ratings, although the capacitance value and voltage rating are directly related to the RMS current rating. The voltage rating of the capacitor and its RMS ripple current capability must never be exceeded.

### Output Capacitor

$C_{OUT}$  – An output capacitor is required to filter the output and provide regulator loop stability. Low impedance or low ESR Electrolytic or solid tantalum capacitors designed for switching regulator applications must be used. When selecting an output capacitor, the important capacitor parameters are the 100-kHz Equivalent Series Resistance (ESR), the RMS ripple current rating, voltage rating, and capacitance value. For the output capacitor, the ESR value is the most important parameter. The ESR must generally not be less than 100 m $\Omega$  or there will be loop instability. If the ESR is too large, efficiency and output voltage ripple are effected, so ESR must be chosen carefully.

### Catch Diode

Buck regulators require a diode to provide a return path for the inductor current when the switch turns off. This must be a fast diode and must be placed close to the LM2591HV using short leads and short printed-circuit traces.

Because of their very fast switching speed and low forward voltage drop, Schottky diodes provide the best performance, especially in low output voltage applications (5 V and lower). Ultra-fast recovery, or high-efficiency rectifiers are also a good choice, but some types with an abrupt turnoff characteristic may cause instability or EMI problems. Ultra-fast recovery diodes typically have reverse recovery times of 50 ns or less. The diode must be chosen for its average/RMS current rating and maximum voltage rating. The voltage rating of the diode must be greater than the DC input voltage (not the output voltage).

### Inverting Regulator

The circuit in [Figure 25](#) converts a positive input voltage to a negative output voltage with a common ground. The circuit operates by bootstrapping the regulator's ground pin to the negative output voltage, then grounding the feedback pin. The regulator senses and regulates the inverted output voltage.

### Application Information (continued)

This example uses the LM2591HV-5.0 to generate a -5-V output, but other output voltages are possible by selecting other output voltage versions, including the adjustable version. Because this regulator topology can produce an output voltage that is either greater than or less than the input voltage, the maximum output current greatly depends on both the input and output voltage.

To determine how much load current is possible before the internal device current limit is reached (and power limiting occurs), the system must be evaluated as a buck-boost configuration rather than as a buck. The peak switch current in amperes, for such a configuration is given as Equation 1:

$$I_{PEAK} = I_{LOAD} \times \left( \frac{V_{IN} + V_{OUT}}{V_{IN}} \right) + \frac{V_{IN} \times V_{OUT} \times 10^6}{2 \times L \times f \times (V_{IN} + V_{OUT})}$$

where

- L is in  $\mu\text{H}$
- and f is in Hz
- The maximum possible load current  $I_{LOAD}$  is limited by the requirement that  $I_{PEAK} \leq I_{CLIM}$  (1)

While checking for this, take  $I_{CLIM}$  to be the lowest possible current limit value (minimum across tolerance and temperature is 1.2 A for the LM2591HV). Also to account for inductor tolerances, take the minimum value of inductance for L in Equation 1 (typically 20% less than the nominal value). Further, Equation 1 disregards the drop across the switch and the diode. This is equivalent to assuming 100% efficiency, which is never so. Therefore expect  $I_{PEAK}$  to be an additional 10% to 20% higher than calculated from Equation 1.

See Application Note AN-1157 (SNVA022) for examples based on positive to negative configuration.

The maximum voltage appearing across the regulator is the absolute sum of the input and output voltage, and this must be limited to a maximum of 60 V. For example, when converting +20 V to -12 V, the regulator would see 32 V between the input pin and ground pin. The LM2591HV has a maximum input voltage spec of 60 V.

Additional diodes are required in this regulator configuration. Diode D1 is used to isolate input voltage ripple or noise from coupling through the  $C_{IN}$  capacitor to the output, under light or no load conditions. Also, this diode isolation changes the topology to closely resemble a buck configuration thus providing good closed loop stability. A Schottky diode is recommended for low input voltages, (because of its lower voltage drop) but for higher input voltages, a fast recovery diode could be used.

Without diode D3, when the input voltage is first applied, the charging current of  $C_{IN}$  can pull the output positive by several volts for a short period of time. Adding D3 prevents the output from going positive by more than a diode voltage.

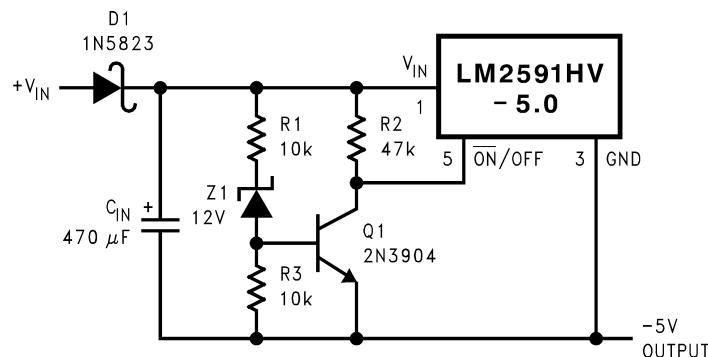

This circuit has hysteresis  
Regulator starts switching at  $V_{IN} = 13\text{ V}$   
Regulator stops switching at  $V_{IN} = 8\text{ V}$

**Figure 24. Undervoltage Lockout With Hysteresis for Inverting Regulator**

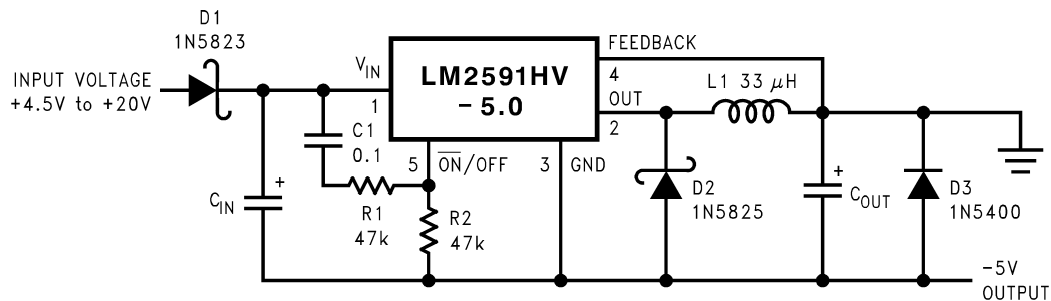
**Application Information (continued)**

$C_{IN}$ —68- $\mu$ F, 25-V Tant. Sprague 595D

470  $\mu$ F/50V Elec. Panasonic HFQ

$C_{OUT}$ —47- $\mu$ F, 20-V Tant. Sprague 595D

220- $\mu$ F, 25-V Elec. Panasonic HFQ

**Figure 25. Inverting -5-V Regulator With Delayed Start-Up**

Because of differences in the operation of the inverting regulator, the standard design procedure is not used to select the inductor value. In the majority of designs, a 33- $\mu$ H, 3-A inductor is the best choice. Capacitor selection can also be narrowed down to just a few values.

This type of inverting regulator can require relatively large amounts of input current when starting up, even with light loads. Input currents as high as the LM2591HV current limit (approx 4 A) are needed for at least 2 ms or more, until the output reaches its nominal output voltage. The actual time depends on the output voltage and the size of the output capacitor. Input power sources that are current-limited or sources that can not deliver these currents without getting loaded down, may not work correctly. Because of the relatively high start-up currents required by the inverting topology, the delayed start-up feature ( $C_1$ ,  $R_1$ , and  $R_2$ ) shown in [Figure 25](#) is recommended. By delaying the regulator start-up, the input capacitor is allowed to charge up to a higher voltage before the switcher begins operating. A portion of the high input current needed for start-up is now supplied by the input capacitor ( $C_{IN}$ ). For severe start-up conditions, the input capacitor can be made much larger than normal.

**Application Information (continued)**

**Inverting Regulator Shutdown Methods**

Using the  $\overline{\text{ON}}/\text{OFF}$  pin in a standard buck configuration is simple. To turn the regulator ON, pull the  $\overline{\text{ON}}/\text{OFF}$  pin below 1.3 V (at 25°C, referenced to ground). To turn regulator OFF, pull the  $\overline{\text{ON}}/\text{OFF}$  pin above 1.3 V. With the inverting configuration, some level shifting is required, because the ground pin of the regulator is no longer at ground, but is now setting at the negative output voltage level. Two different shutdown methods for inverting regulators are shown in [Figure 26](#) and [Figure 27](#).

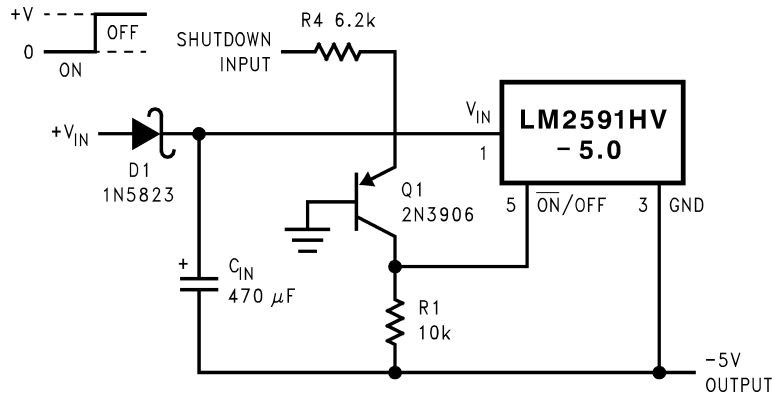

**Figure 26. Inverting Regulator Ground Referenced Shutdown**

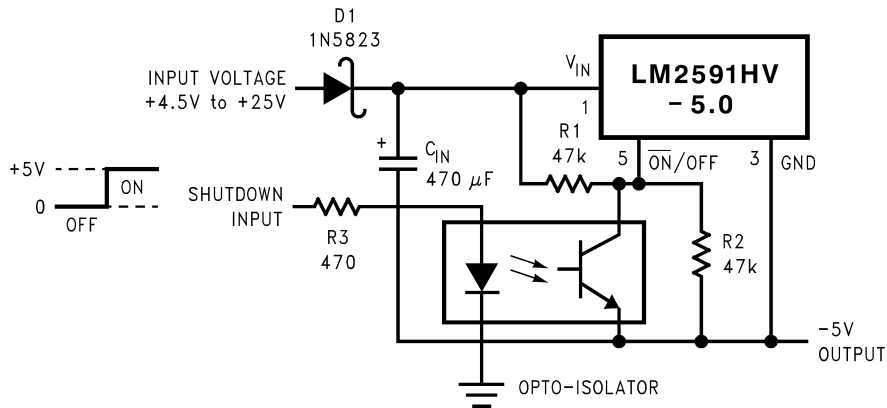

**Figure 27. Inverting Regulator Ground Referenced Shutdown Using Opto Device**



**Typical Application**

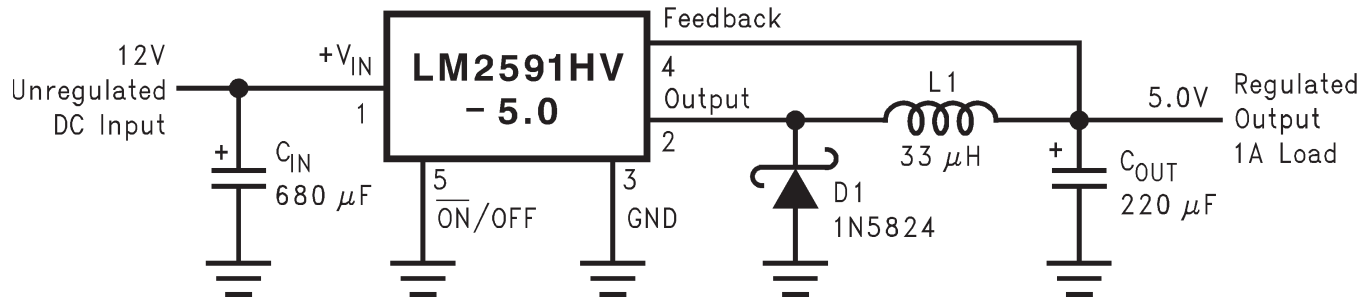

Copyright © 2016, Texas Instruments Incorporated

**Figure 28. Typical Application**

**Design Requirements**

Table 1 lists the parameters for this design example.

**Table 1. Example Parameters**

PARAMETER	EXAMPLE VALUE
Regulated output voltage, $V_{OUT}$	20 V
Maximum input voltage, $V_{IN(max)}$	24 V
Maximum load current, $I_{LOAD(max)}$	1 A
Switching frequency, F	Fixed at a nominal 150 kHz

**Detailed Design Procedure**

**Inductor Selection Procedure**

See Application Note AN-1197 (SNVA038) for detailed information on selecting inductors for buck converters. For a quick-start, the designer may refer to the nomographs provided in Figure 29 to Figure 31. To give designers more options of available inductors, the nomographs provide the required inductance and also the energy in the core expressed in microjoules ( $\mu J$ ), as an alternative to just prescribing custom parts. The following points must be highlighted:

1. The energy values shown on the nomographs apply to steady operation at the corresponding x-coordinate (rated maximum load current). However, under start-up, without soft start, or a short circuit on the output, the current in the inductor will momentarily or repetitively hit the current limit  $I_{CLIM}$  of the device, and this current could be much higher than the rated load,  $I_{LOAD}$ . This represents an overload situation, and can cause the inductor to saturate (if it has been designed only to handle the energy of steady operation). However, most types of core structures used for such applications have a large inherent air gap (for example, powdered iron types or ferrite rod inductors), so the inductance does not fall off too sharply under an overload. The device is usually able to protect itself by preventing the current from exceeding  $I_{CLIM}$ . However, if the DC input voltage to the regulator is over 40 V, the current can slew up so fast under core saturation that the device may not be able to act fast enough to restrict the current. The current can then rise without limit until the device is destroyed.

2. The energy under steady operation is given in [Equation 2](#):

$$e = \frac{1}{2} \times L \times I_{PEAK}^2 \quad \mu\text{J}$$

where

- L is in  $\mu\text{H}$
- $I_{PEAK}$  is the peak of the inductor current waveform with the regulator delivering  $I_{LOAD}$ .

These are the energy values shown in the nomographs. See [Example 1](#).

3. The energy under overload is given in [Equation 3](#):

$$e_{CLIM} = \frac{1}{2} \times L \times I_{CLIM}^2 \quad \mu\text{J} \quad (3)$$

If  $V_{IN} > 40 \text{ V}$ , the inductor must be sized to handle  $e_{CLIM}$  instead of the steady energy values. The worst case  $I_{CLIM}$  for the LM2591HV is 3 A. The energy rating depends on the inductance. See [Example 2](#).

4. The nomographs were generated by allowing a greater amount of percentage current ripple in the inductor as the maximum rated load decreases (see [Figure 32](#)). This was done to allow smaller inductors to be used at light loads. However, [Figure 32](#) shows only the *median* value of the current ripple. In reality there may be a great spread around this because the nomographs approximate the exact calculated inductance to standard available values. It is a good idea to refer to AN-1197 ([SNVA038](#)) for detailed calculations if a certain maximum inductor current ripple is required for various possible reasons. Also consider the rather wide tolerance on the nominal inductance of commercial inductors.
5. [Figure 31](#) shows the inductor selection curves for the Adjustable version. The y-axis is 'Et', in  $V\mu\text{secs}$ . It is the applied volts across the inductor during the ON time of the switch ( $V_{IN} - V_{SAT} - V_{OUT}$ ) multiplied by the time for which the switch is on in  $\mu\text{s}$ . See [Example 3](#).

**Example 1:** ( $V_{IN} \leq 40 \text{ V}$ ) LM2591HV-5.0,  $V_{IN} = 24 \text{ V}$ , Output 5 V at 0.8 A

1. A first pass inductor selection is based upon *inductance and rated max load current*. Choose an inductor with the inductance value indicated by the nomograph (see [Figure 30](#)) and a current rating equal to the maximum load current. Therefore, quick-select a 100- $\mu\text{H}$ , 0.8-A inductor (designed for 150-kHz operation) for this application.
2. Confirm that it is rated to handle 50  $\mu\text{J}$  (see [Figure 30](#)) by either estimating the peak current or by a detailed calculation as shown in AN-1197 ([SNVA038](#)). Also, confirm that the losses are acceptable.

**Example 2:** ( $V_{IN} > 40 \text{ V}$ ) LM2591HV-5.0,  $V_{IN} = 48 \text{ V}$ , Output 5 V at 1 A

1. A first pass inductor selection is based upon *inductance and the switch current limit*. We choose an inductor with the inductance value indicated by the nomograph ([Figure 30](#)) and a current rating equal to  $I_{CLIM}$ . Therefore, quick-select a 100- $\mu\text{H}$ , 3-A inductor (designed for 150-kHz operation) for this application.
2. Confirm that it is rated to handle  $e_{CLIM}$  by the procedure shown in AN-1197 ([SNVA038](#)) and that the losses are acceptable. Here  $e_{CLIM}$  is calculated using [Equation 4](#):

$$e_{CLIM} = \frac{1}{2} \times 100 \times 3^2 = 450 \quad \mu\text{J} \quad (4)$$

**Example 3:** ( $V_{IN} \leq 40 \text{ V}$ ) LM2591HV-ADJ,  $V_{IN} = 20 \text{ V}$ , Output 10 V at 1 A

1. Because input voltage is less than 40 V, a first pass inductor selection is based upon inductance and rated maximum load current. We choose an inductor with the inductance value indicated by the nomograph [Figure 31](#) and a current rating equal to the maximum load. First, calculate Et for the given application. The duty cycle is calculated with [Equation 5](#):

$$D = \frac{V_{OUT} + V_D}{V_{IN} - V_{SAT} + V_D}$$

where

- $V_D$  is the drop across the catch diode ( $\approx 0.5 \text{ V}$  for a Schottky)
- $V_{SAT}$  the drop across the switch ( $\approx 1.5 \text{ V}$ )

Substituting in the values gives Equation 6:

$$D = \frac{10 + 0.5}{20 - 1.5 + 0.5} = 0.55 \quad (6)$$

And the switch ON time is calculated with Equation 7:

$$t_{ON} = \frac{D}{f} \times 10^6 \mu\text{s}$$

where

- f is the switching frequency in Hz (7)

So

$$\begin{aligned} E_t &= (V_{IN} - V_{SAT} - V_{OUT}) \times t_{ON} \\ &= (20 - 1.5 - 10) \times \frac{0.55}{150000} \times 10^6 \text{ V}\mu\text{secs} \\ &= 31.3 \text{ V}\mu\text{secs} \end{aligned} \quad (8)$$

Therefore, looking at Figure 29, quick-select a 100- $\mu\text{H}$ , 1-A inductor (designed for 150-kHz operation) for this application.

2. Confirm that the inductor is rated to handle 100  $\mu\text{J}$  (see Figure 31) by the procedure shown in AN-1197 (SNVA038) and that the losses are acceptable. (If the DC input voltage is greater than 40 V, consider  $e_{CLIM}$  as shown in Example 2).

**NOTE**

Take  $V_{SAT}$  as 1.5 V which includes an estimated resistive drop across the inductor.

This completes the simplified inductor selection procedure. See AN-1197 (SNVA038), for more general applications and better optimization.

**Application Curves**

(For Continuous Mode Operation)

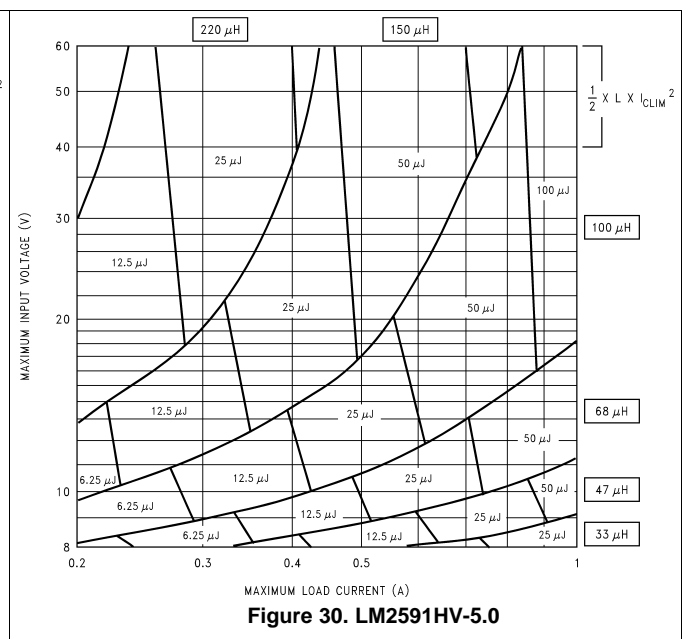
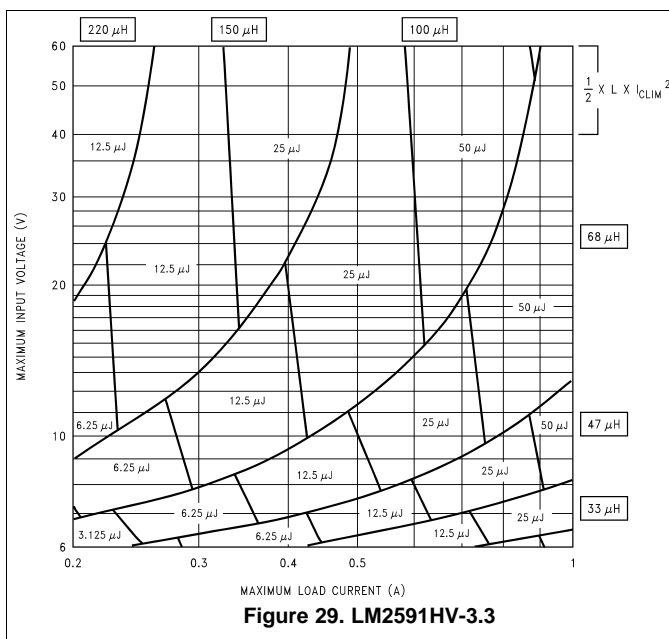

(For Continuous Mode Operation)

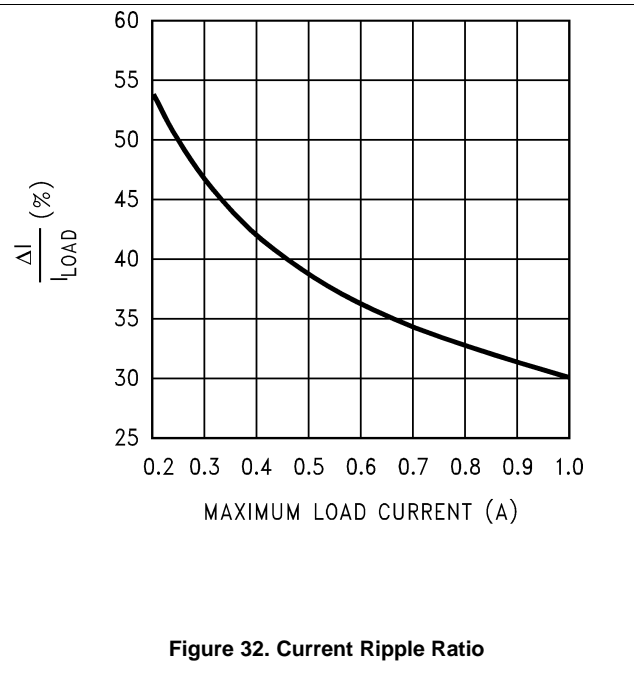
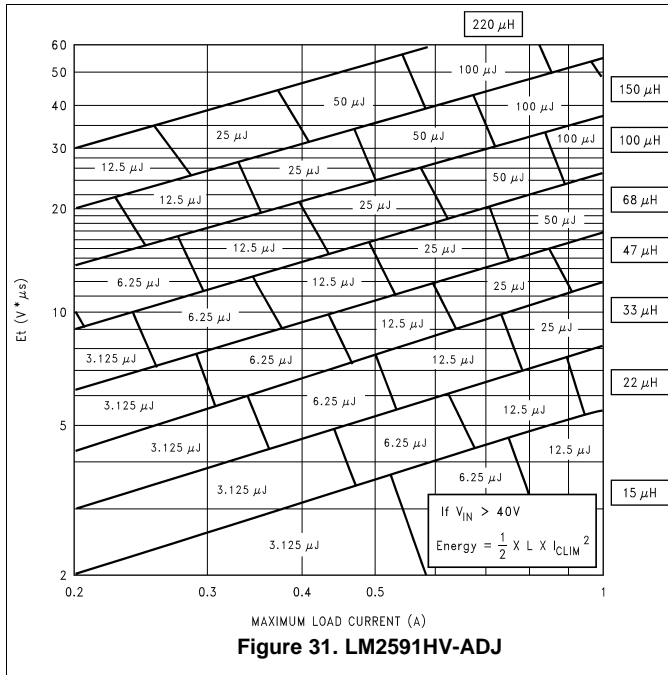

## Power Supply Recommendations

The LM2591HV is designed to operate from an input voltage supply up to 60 V. This input supply must be well regulated, able to withstand maximum input current, and maintain a stable voltage.

## Layout

### Layout Guidelines

As in any switching regulator, layout is very important. Rapid switching currents associated with wiring inductance can generate voltage transients, which can cause problems. For minimal inductance and ground loops (see [Test Circuits](#)), the wires indicated by heavy lines must be wide printed-circuit traces and must be kept as short as possible. For best results, external components must be placed as close to the switcher IC as possible using ground plane construction or single-point grounding.

If open core inductors are used, take special care as to the location and positioning of this type of inductor. Allowing the inductor flux to intersect sensitive feedback, IC groundpath, and C<sub>OUT</sub> wiring can cause problems.

When using the adjustable version, take special care as to the location of the feedback resistors and the associated wiring. Physically place both resistors near the IC, and route the wiring away from the inductor, especially an open core type of inductor.

## X-ON Electronics

Largest Supplier of Electrical and Electronic Components

*Click to view similar products for [Isolated DC/DC Converters](#) category:*

*Click to view products by [HGSEMI](#) manufacturer:*

Other Similar products are found below :

[ESM6D044440C05AAQ](#) [FMD15.24G](#) [PSL486-7LR](#) [PSR152.5-7IR](#) [Q48T30020-NBB0](#) [AVO240-48S12B-6L](#) [AVO250-48S28B-6L](#) [NAN-0505](#) [HW-L16D](#) [JAHW100Y1](#) [217-1617-001](#) [22827](#) [SPB05C-12](#) [SQ24S15033-PS0S](#) [18952](#) [19-130041](#) [CE-1003](#) [CE-1004](#) [GQ2541-7R](#) [PSE1000DCDC-12V](#) [RDS180245](#) [MAU228](#) [419-2065-201](#) [449-2075-101](#) [TME 0303S](#) [TME 0505S](#) [TME 1205S](#) [TME 1212S](#) [TME 2405S](#) [TME 2412S](#) [J80-0041NL](#) [V300C24C150BG](#) [419-2062-200](#) [419-2063-401](#) [419-2067-101](#) [419-2067-501](#) [419-2068-001](#) [DCG40-5G](#) [DFC15U48D15](#) [449-2067-000](#) [XGS-0512](#) [XGS-1205](#) [XGS-1212](#) [XGS-2412](#) [XGS-2415](#) [XKS-1215](#) [033456](#) [NCT1000N040R050B](#) [SPB05B-15](#) [SPB05C-15](#)