

## 2.5V VOLTAGE REFERENCES

- LOW TEMPERATURE COEFFICIENT
- WIDE OPERATING CURRENT OF 400 $\mu$ A TO 10mA
- 0.2 $\Omega$  DYNAMIC IMPEDANCE
- GUARANTEED TEMPERATURE STABILITY
- FAST TURN-ON



**D SO8**  
(Plastic Micropackage)

**SO8**  
(Top view)

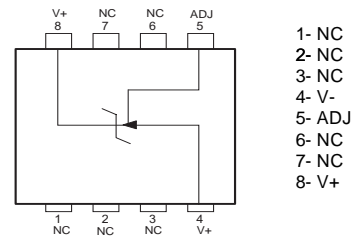

### DESCRIPTION

The LM336 are precision 2.5V regulator diodes. These voltage reference monolithic ICs operate like 2.5V zener diodes with a low temperature coefficient and a dynamic impedance of 0.2 $\Omega$ . A third pin enables adjusting the reference voltage and the temperature coefficient.

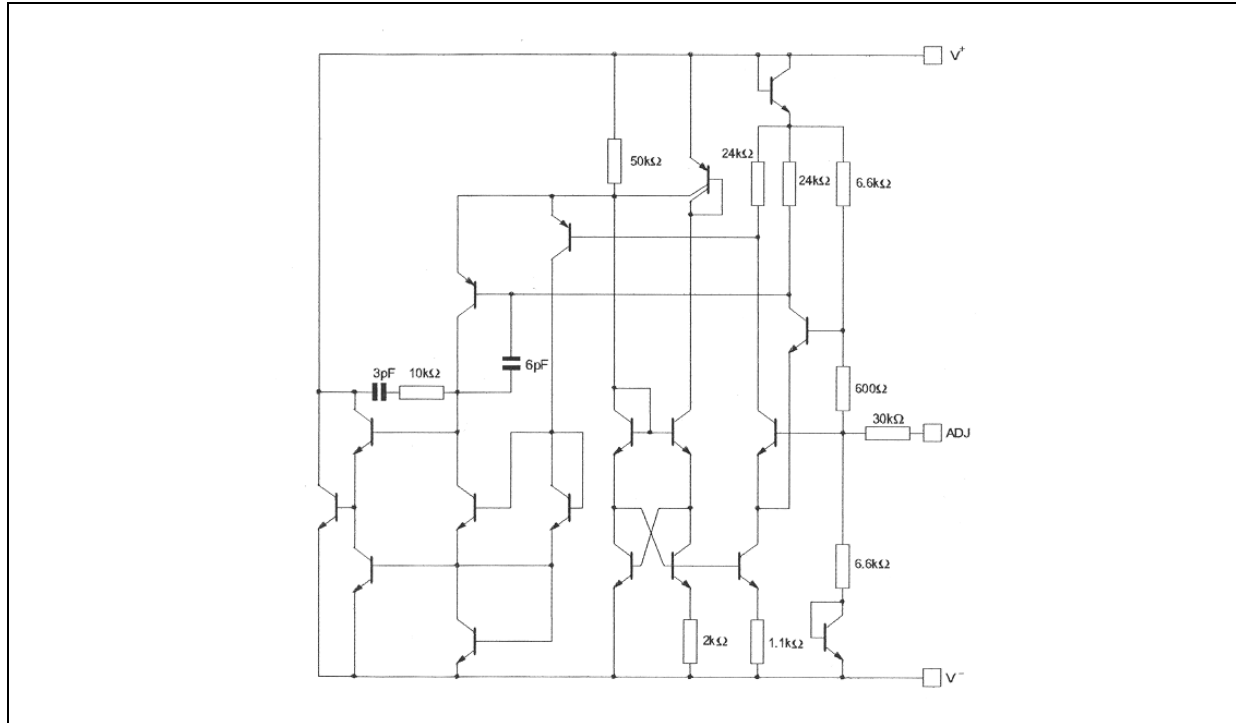
**SCHEMATIC DIAGRAM**

**ABSOLUTE MAXIMUM RATINGS**

Symbol	Parameter	LM336	Unit
$I_R$ $I_F$	Current Reverse Forward	15 10	mA
$T_{oper}$	Operating Free-air Temperature Range	0 to +70	°C
$T_{Stg}$	Storage Temperature Range	-65 to +150	°C

**ELECTRICAL CHARACTERISTICS**

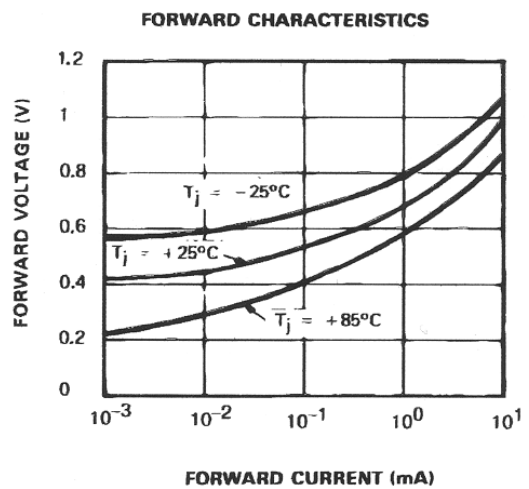
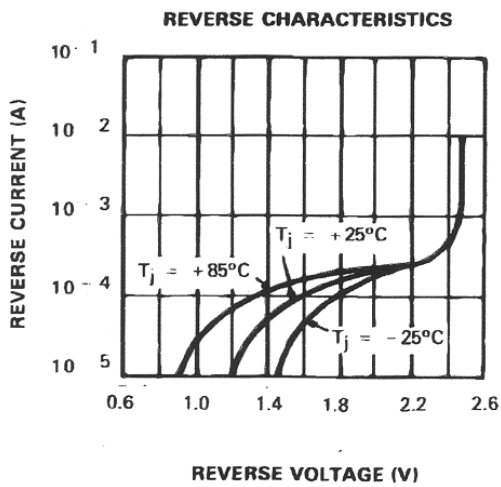
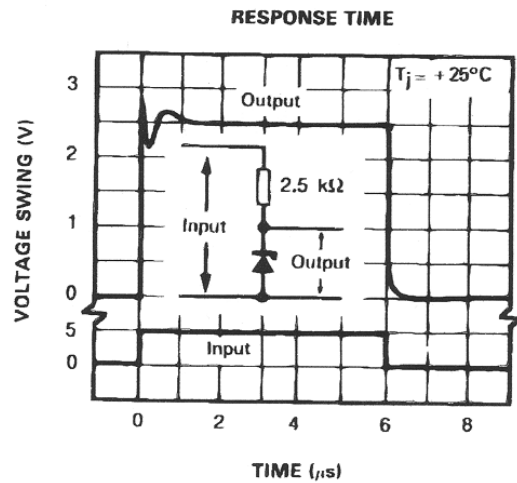
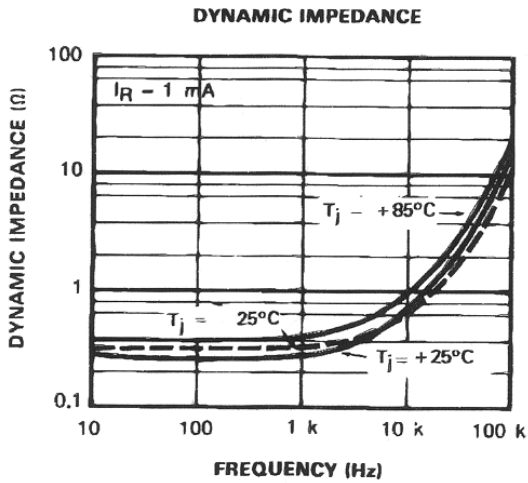
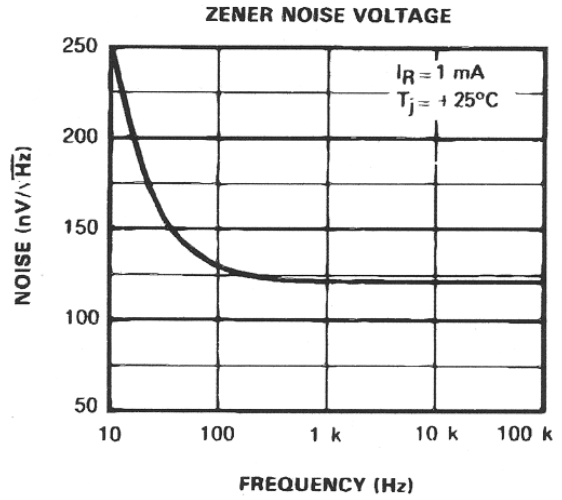
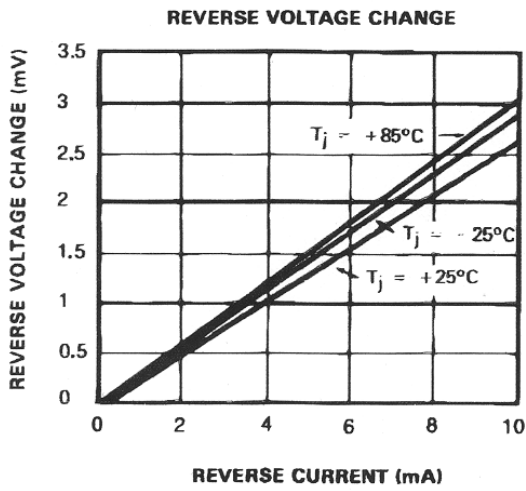
Symbol	Parameter	LM336			Unit
		Min.	Typ.	Max.	
$V_R$	Reference Breakdown Voltage $T_{amb} = +25^\circ\text{C}$ , $I_R = 1\text{mA}$ LM336	2.44	2.49	2.54	V
$\Delta V_R$	Reverse Breakdown Voltage Change with Current $400\mu\text{A} \leq I_R \leq 10\text{mA}$ $T_{amb} = +25^\circ\text{C}$ $T_{min.} \leq T_{amb} \leq T_{max.}$		2.6 3	10 12	mV
$Z_D$	Reverse Dynamic Impedance ( $I_R = 1\text{mA}$ ) $T_{amb} = +25^\circ\text{C}$ $T_{min.} \leq T_{amb} \leq T_{max.}$		0.2 0.4	1 1.4	$\Omega$
$K_{VT}$	Temperature Stability ( $V_R = 2.49\text{V}$ , $I_R = 1\text{mA}$ )		1.8	6	mV
$K_{VH}$	Long Term Stability ( $T_{amb} = +25^\circ\text{C} \pm 0.1^\circ\text{C}$ , $I_R = 1\text{mA}$ )		20		ppm

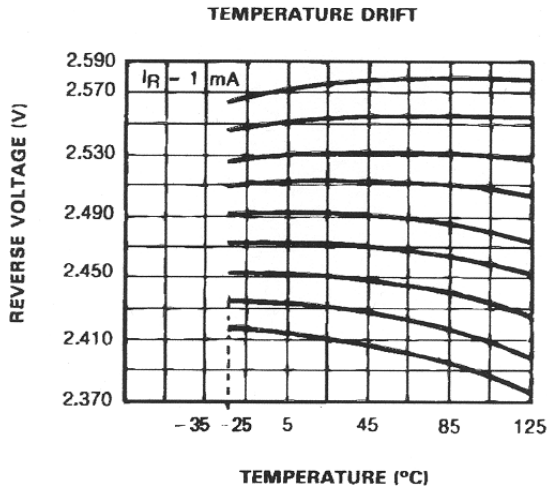



**Figure 1 :** The LM336 with Pot for Adjustment of Breakdown Voltage

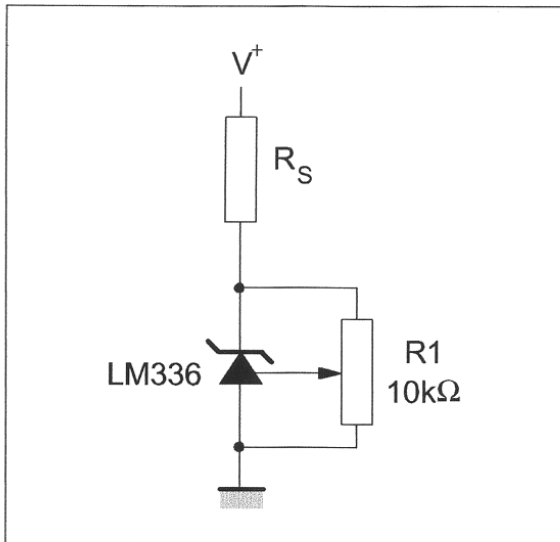

**APPLICATION HINTS**

The LM336 voltage references are easier to use than zener diodes. Their low impedance and wide current range facilitate biasing in any circuits. Besides, the breakdown voltage or the temperature coefficient can be adjusted so as to optimize the performance of the circuit.

Figure 1 represents a LM336 with a 10kΩ potentiometer to adjust the reverse breakdown voltage which can be adjusted without altering the temperature coefficient of the circuit. The adjustment range is generally sufficient to adjust the initial tolerance of the circuit and the inaccuracy of the amplifier circuit.

To obtain a lower temperature coefficient two diodes can be connected in series as indicated in Figure 2.

When the circuit is adjusted to 2.49V the temperature coefficient is minimized.

For a correct temperature coefficient, the diodes should be at the same ambient temperature as the LM336. The value of R1 is not critical (2-20kΩ).

**Figure 2 :** Temperature Coefficient Adjustment

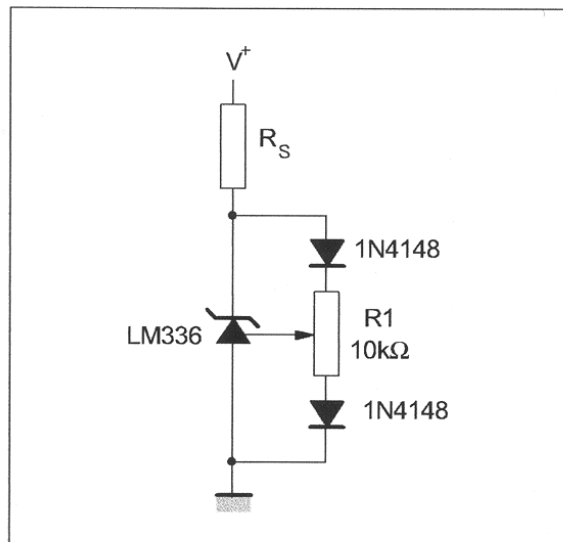

**TYPICAL APPLICATIONS**

**Figure 3 : 2.5V Reference**

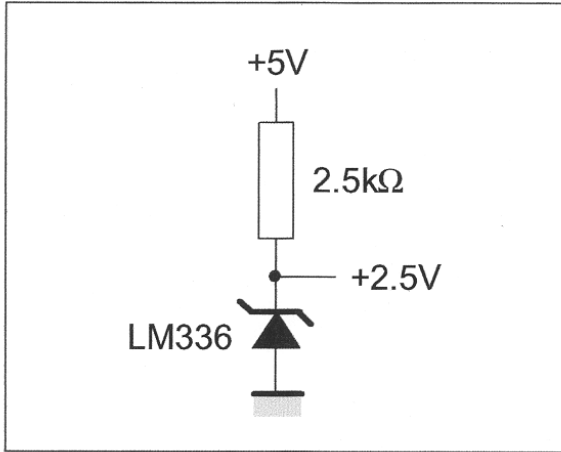

**Figure 4 : Wide Input Range Reference**

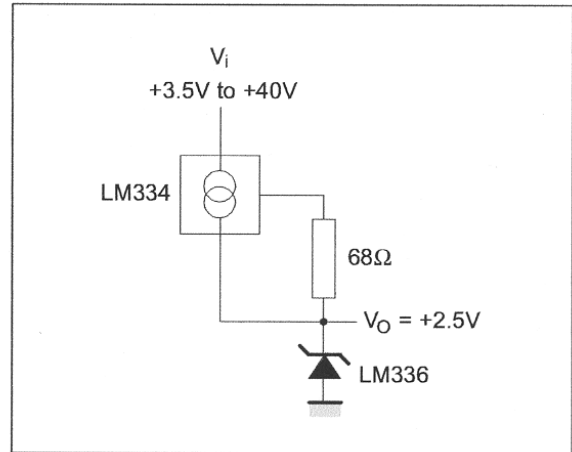

**Figure 5 : Precision Power Regulator with Low Temperature Coefficient**

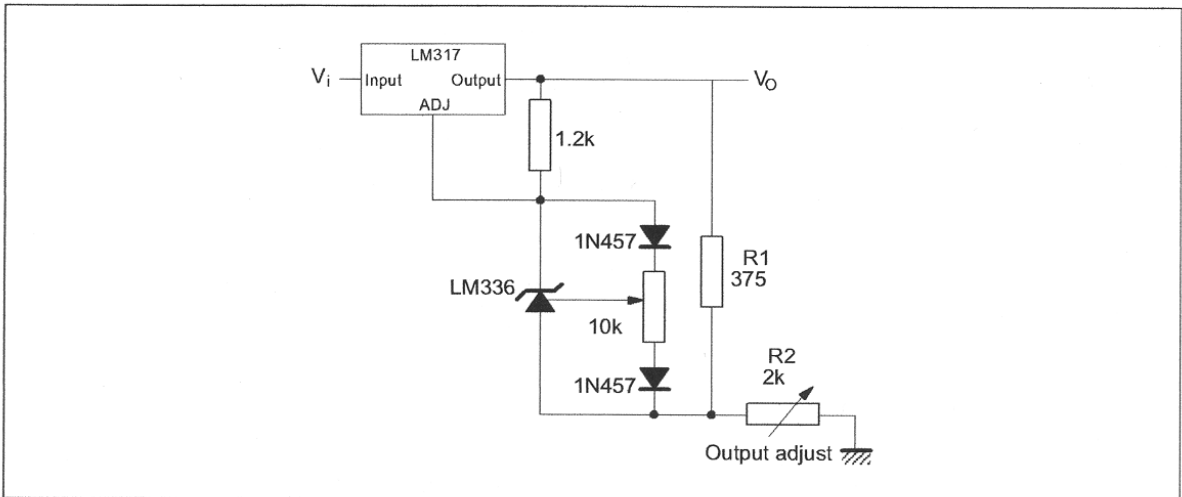

**Figure 6 : Adjustable Shunt Regulator**

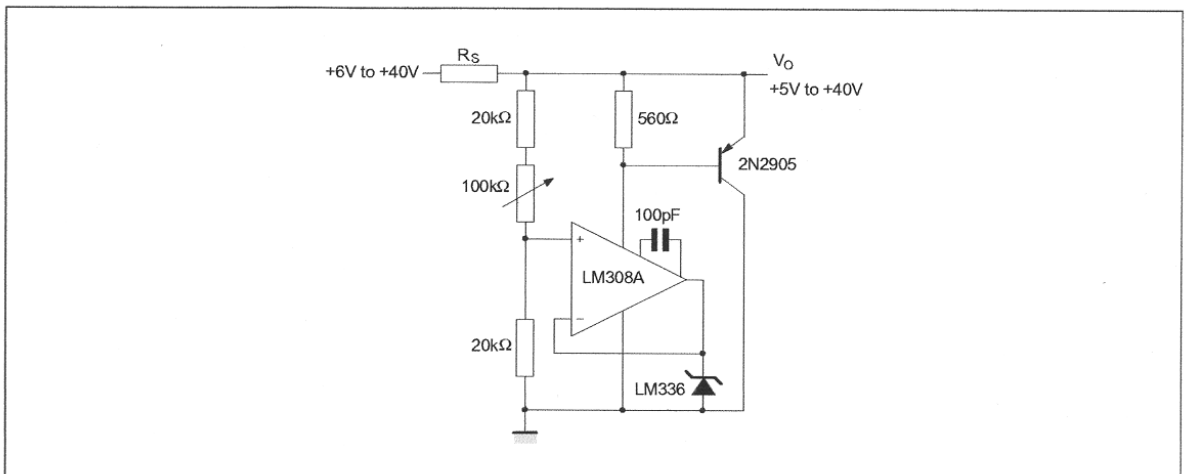

**Figure 7 : Linear Ohmmeter**

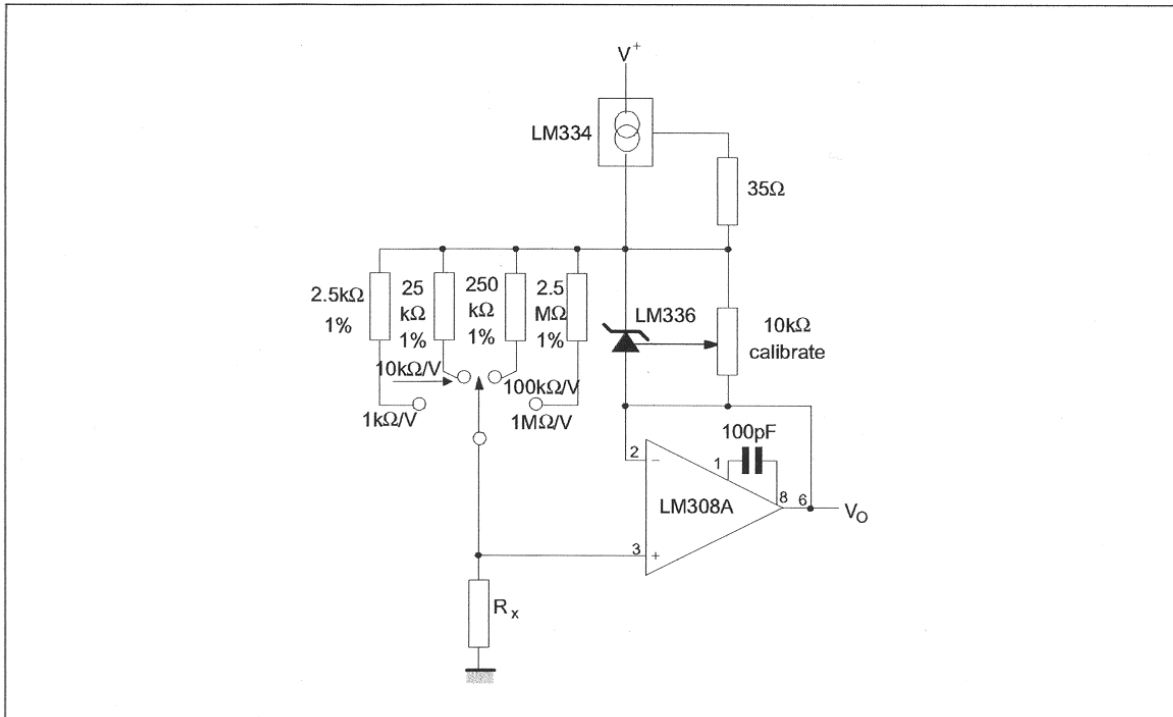

**Figure 8 : Bipolar Output Reference**

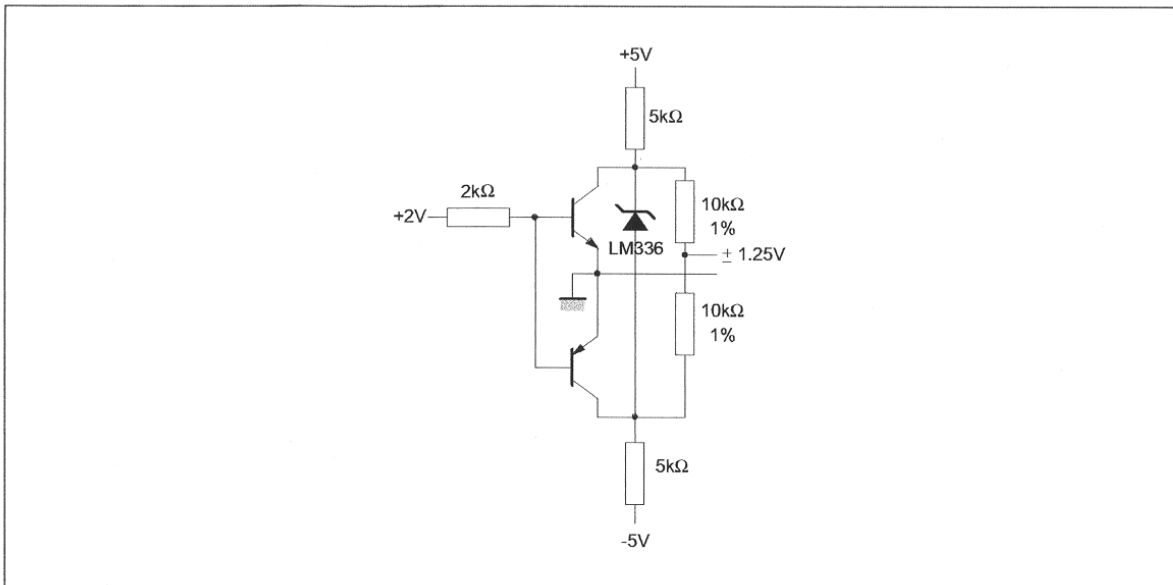

**Figure 9 : 5V Buffered Reference**

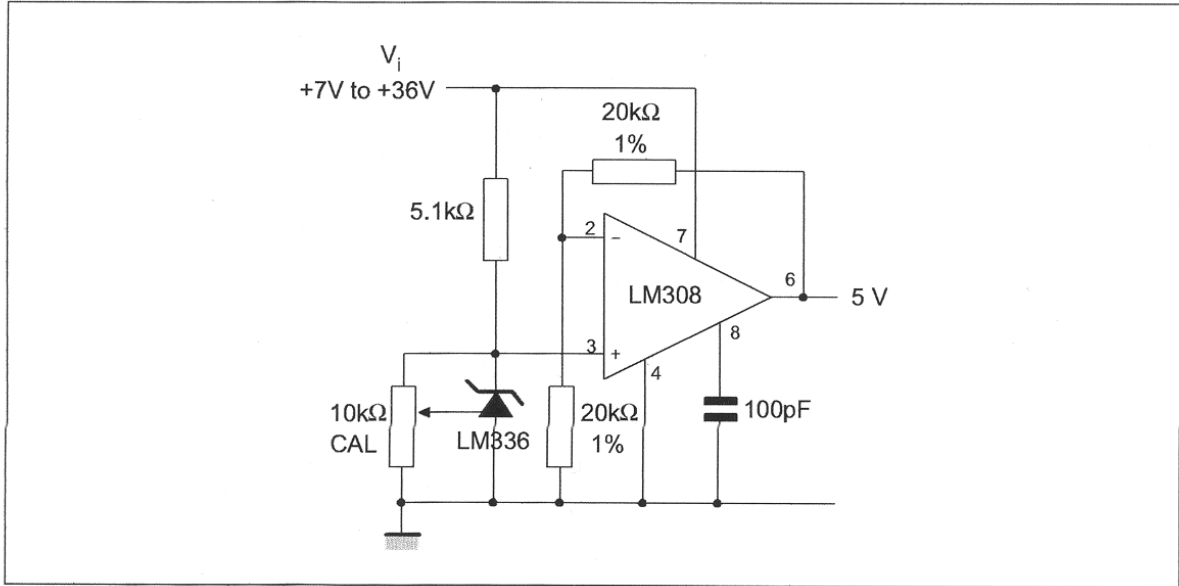

**Figure 10 : Low Noise Buffered Reference**

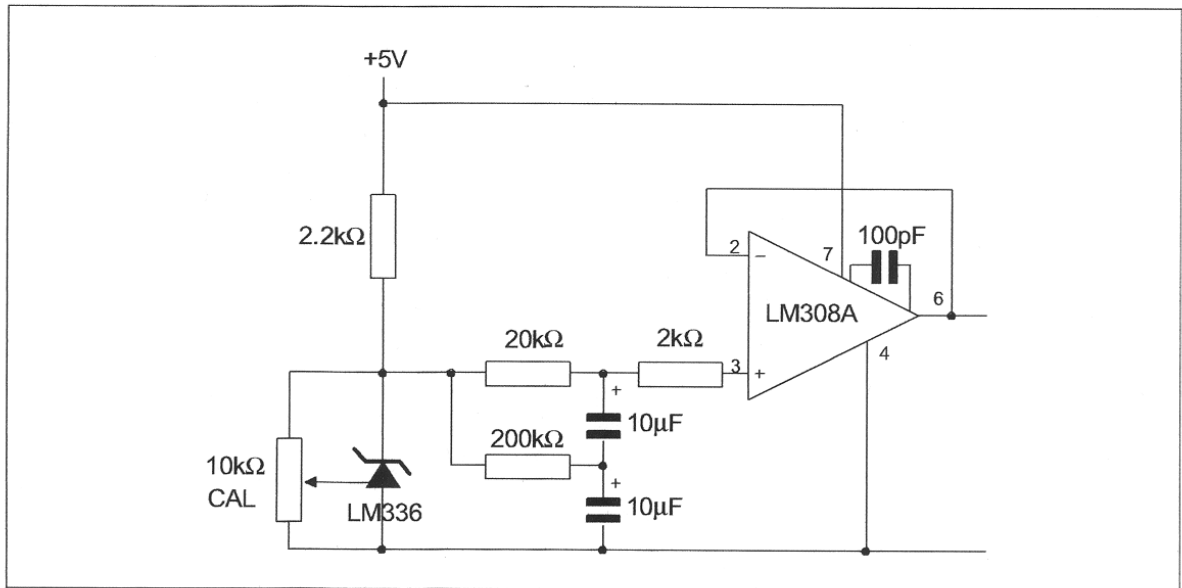

## X-ON Electronics

Largest Supplier of Electrical and Electronic Components

*Click to view similar products for [Voltage References](#) category:*

*Click to view products by [HGSEMI](#) manufacturer:*

Other Similar products are found below :

[622664A](#) [636116E](#) [748389C](#) [AS431ARTR-E1](#) [NCP431BCSNT1G](#) [NCP432BCSNT1G](#) [NCV431BSNT1G](#) [AP4313UKTR-G1](#)  
[TL1431AIYDT](#) [AZ431BR-ATRE1](#) [622668D](#) [NCP432BVSNT1G](#) [5962-8686103XC](#) [NCV431BVDMR2G](#) [AZ432BNTR-G1](#)  
[AP4306BUKTR-G1](#) [SC431BVSNT1G](#) [MAX6023EBT30+T](#) [NCV431ASNT1G](#) [LM4040CEM3-5.0/V+T](#) [LT1460KCS3-3#TRM](#)  
[LT1460KCS3-3.3#TRM](#) [LT6660KCDC-10#TRMPBF](#) [LTC6652BHLS8-5#PBF](#) [LTC6652AHLS8-4.096#PBF](#) [LTC6655BHLS8-4.096#PBF](#)  
[LT6660HCDC-5#TRMPBF](#) [LM336Z-2.5#PBF](#) [LT1021BMH-10](#) [SC431ILPRAG](#) [TLVH431MIL3T](#) [MAX6023EBT21+T](#) [AP432AQG-7](#)  
[ADR4540CRZ](#) [LM4040B25QFTA](#) [TS3325AQPR](#) [REF102AU/2K5](#) [TL4050B25QDBZR](#) [TL4051C12QDCKR](#) [TL431ACZ](#) [KA431SLMF2TF](#)  
[KA431SMF2TF](#) [KA431SMFTF](#) [LM385BXZ/NOPB](#) [LM4040QCEM3-3.0/NOPB](#) [LM4041C12ILPR](#) [LM4050AEM3X-5.0/NOPB](#)  
[LM4050AIM3X-5.0/NOPB](#) [LM4120AIM5-2.5/NOP](#) [LM431SCCMFX](#)