

DESCRIPTION

The LM236 and LM336 are precision 5.0V regulator diodes. These voltage reference monolithic ICs operate like 5.0V zener diodes with a low temperature coefficient and a dynamic impedance of 0.6Ω. A third pin enables adjusting the reference voltage and the temperature coefficient.

Features

- Adjustable 4V to 6V
- Low temperature coefficient
- Wide operating current of 600 μA to 10 mA
- 0.6Ω dynamic impedance
- ± 1% initial tolerance available
- Guaranteed temperature stability
- Easily trimmed for minimum temperature drift
- Fast turn-on
- Three lead transistor package

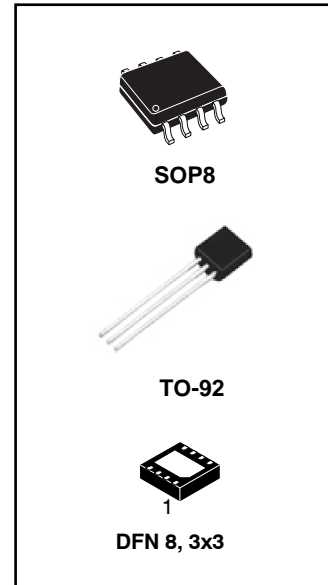

ORDERING INFORMATION

DEVICE	Package Type	MARKING	Packing	Packing Qty
LM236M-5.0/TR	SOP8L	LM236-5	Reel	2500pcs/reel
LM336M-5.0/TR	SOP8L	LM336-5	Reel	2500pcs/reel
LM236Z-5.0	TO-92	LM236-5	Tape	1000pcs/box
LM336Z-5.0	TO-92	LM336-5	Tape	1000pcs/box
LM236DQ-5.0/TR	DFN-8	LM236-5	Reel	2500pcs/reel
LM336DQ-5.0/TR	DFN-8	LM336-5	Reel	2500pcs/reel

Typical Applications

5.0V Reference

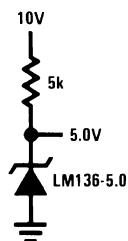

5.0V Reference with Minimum Temperature Coefficient

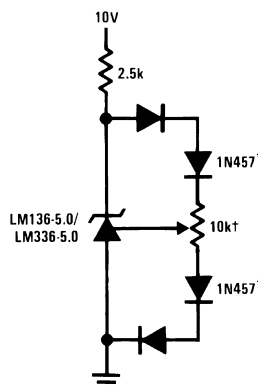

† Adjust to 5.00V
* Any silicon signal diode

Trimmed 4V to 6V Reference with Temperature Coefficient Independent of Breakdown Voltage

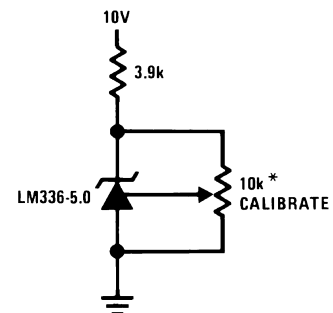

* Does not affect temperature coefficient

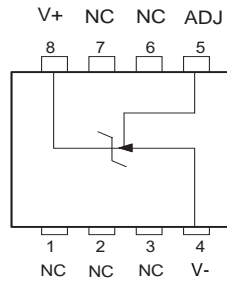
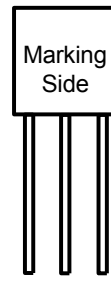
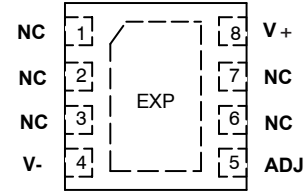
PIN CONNECTIONS

S08
 (Top view)

TO-92 PKG
 1 2 3
 ADJ V+ V-

DFN-8 3*3
 (Top view)

ABSOLUTE MAXIMUM RATINGS

Symbol	Parameter	LM336	Unit
I_R I_F	Current Reverse Forward	15 10	mA
T_{oper}	Operating Free-air Temperature Range	LM336-5.0: 0 to +70 LM236-5.0: -40 to +85	°C
T_{Stg}	Storage Temperature Range	-65 to +150	°C

SOP Package

Vapor Phase (60 sec.)

215°C

Infrared (15 sec.)

220°C

ELECTRICAL CHARACTERISTICS

Symbol	Parameter	LM236/LM336			Unit
		Min.	Typ.	Max.	
V_R	Reference Breakdown Voltage $T_{amb} = +25^\circ\text{C}$, $I_R = 1\text{mA}$	4.9	5.0	5.1	V
ΔV_R	Reverse Breakdown Voltage Change with Current $600\mu\text{A} \leq I_R \leq 10\text{mA}$ $T_{amb} = +25^\circ\text{C}$ $T_{min.} \leq T_{amb} \leq T_{max.}$	-	6	20	mV
Z_D	Reverse Dynamic Impedance ($I_R = 1\text{mA}$) $T_{amb} = +25^\circ\text{C}$ $f=100\text{Hz}$ $T_{min.} \leq T_{amb} \leq T_{max.}$	-	0.6	2.0	Ω
K_{VT}	Temperature Stability ($V_R = 5.0\text{V}$, $I_R = 1\text{mA}$)	-	4	12	mV
K_{VH}	Long Term Stability ($T_{amb} = +25^\circ\text{C} \pm 0.1^\circ\text{C}$, $I_R = 1\text{mA}$)	-	20	-	ppm

Typical Performance Characteristics

Reverse Voltage Change

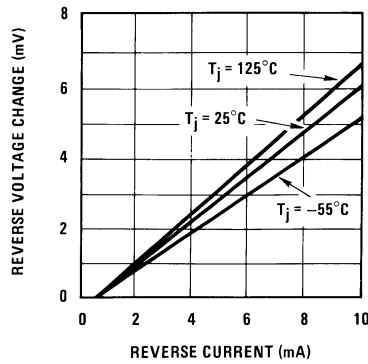

Zener Noise Voltage

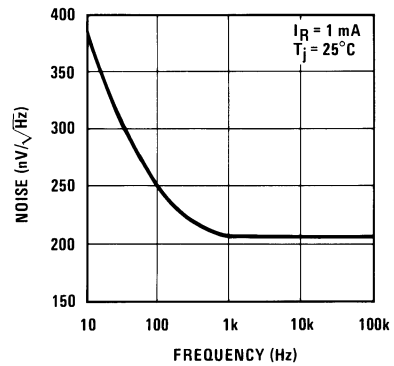

Dynamic Impedance

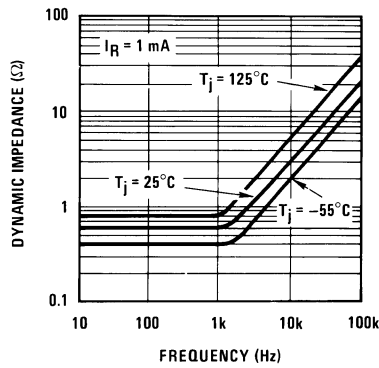

Response Time

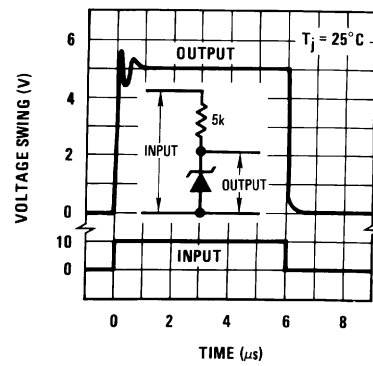

Reverse Characteristics

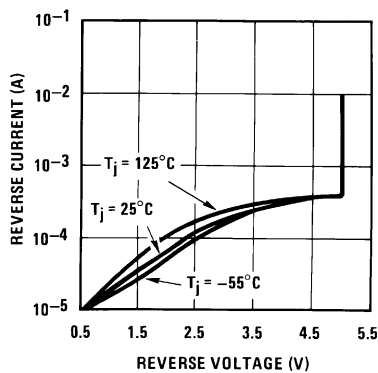

Temperature Drift

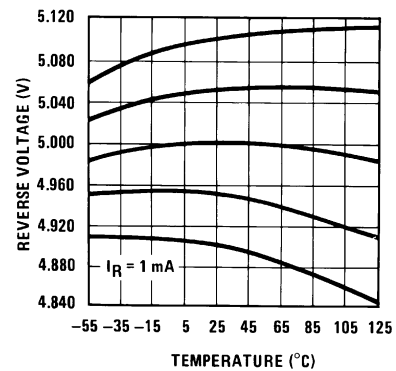

Typical Performance Characteristics (Continued)

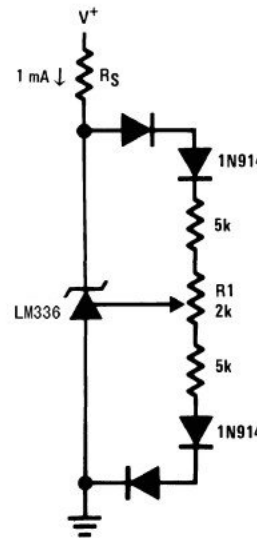
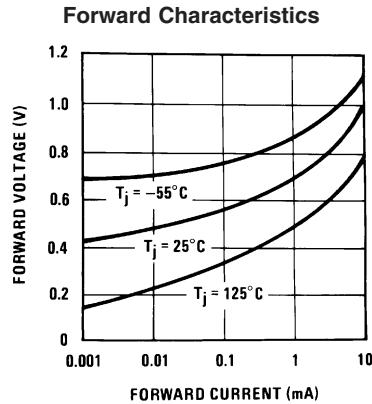

FIGURE 2. Temperature Coefficient Adjustment (Trim Range = ±0.5V Typical)

Application Hints

The LMx36-5.0 series voltage references are much easier to use than ordinary zener diodes. Their low impedance and wide operating current range simplify biasing in almost any circuit. Further, either the breakdown voltage or the temperature coefficient can be adjusted to optimize circuit performance.

Figure 1 shows an LM336-5.0 with a 10k potentiometer for adjusting the reverse breakdown voltage. With the addition of R1 the breakdown voltage can be adjusted without affecting the temperature coefficient of the device. The adjustment range is usually sufficient to adjust for both the initial device tolerance and inaccuracies in buffer circuitry.

If minimum temperature coefficient is desired, four diodes can be added in series with the adjustment potentiometer as shown in Figure 2. When the device is adjusted to 5.00V the temperature coefficient is minimized. Almost any silicon signal diode can be used for this purpose such as a 1N914, 1N4148 or a 1N457. For proper temperature compensation the diodes should be in the same thermal environment as the LM336-5.0. It is usually sufficient to mount the diodes near the LM336-5.0 on the printed circuit board. The absolute resistance of the network is not critical and any value from 2k to 20k will work. Because of the wide adjustment range, fixed resistors should be connected in series with the pot to make pot setting less critical.

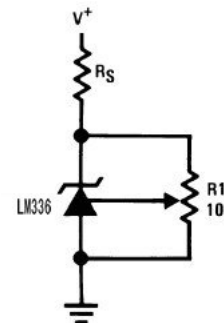
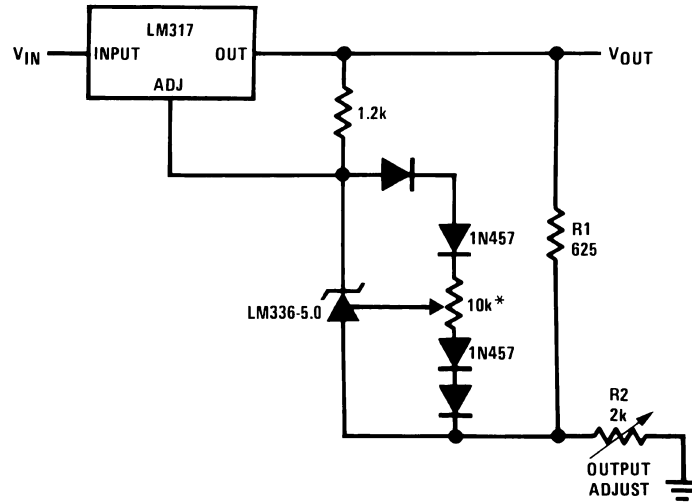

FIGURE 1. LM336-5.0 with Pot for Adjustment of Breakdown Voltage (Trim Range = ±1.0V Typical)

Typical Applications



Precision Power Regulator with Low Temperature Coefficient

* Adjust for 6.25V across R1

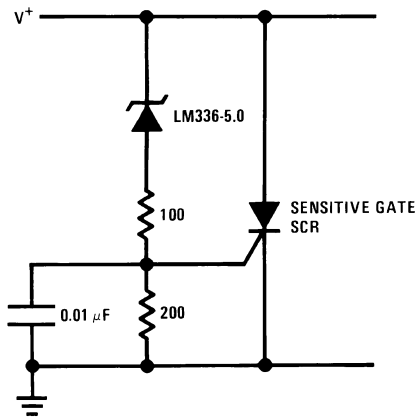

5V Crowbar

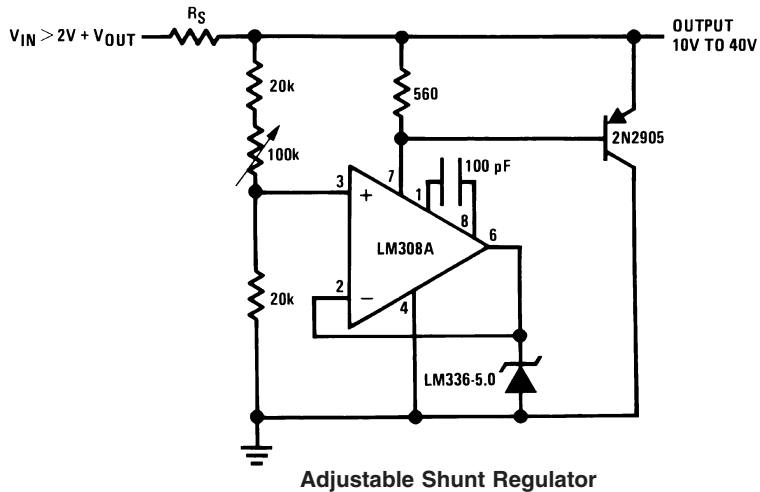

Adjustable Shunt Regulator

Typical Applications (Continued)

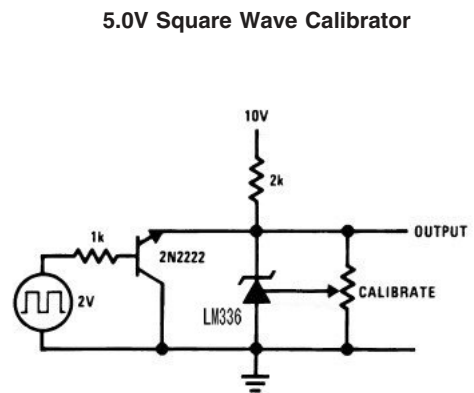
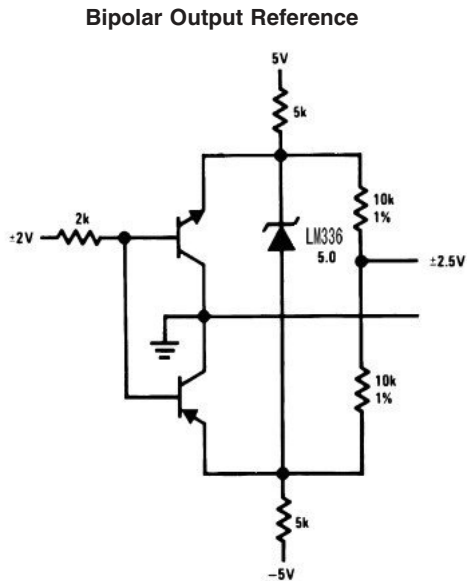
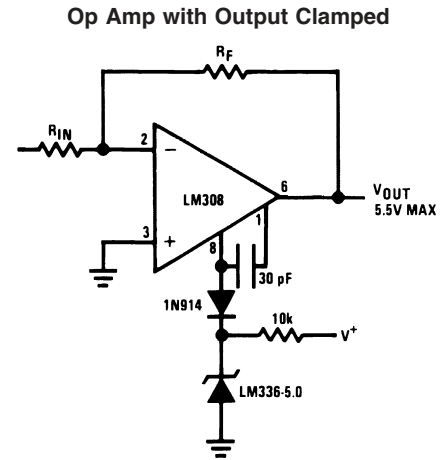
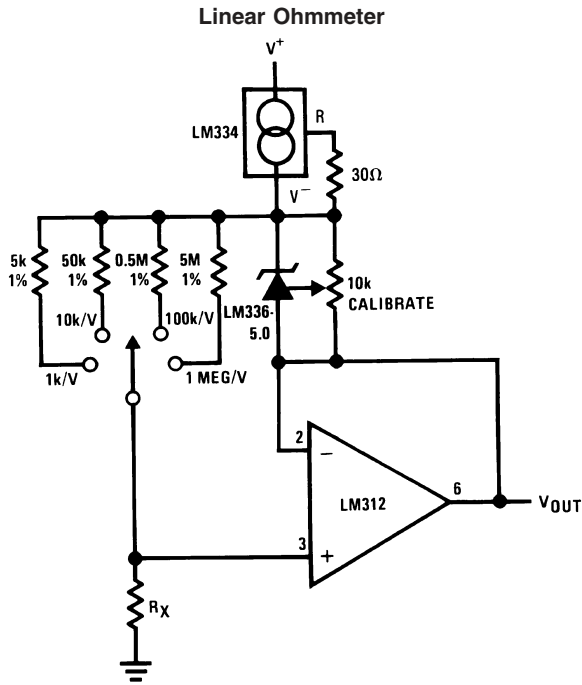

Typical Applications (Continued)

10V Buffered Reference

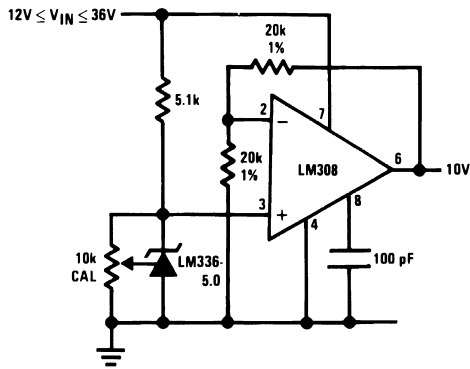

Low Noise Buffered Reference

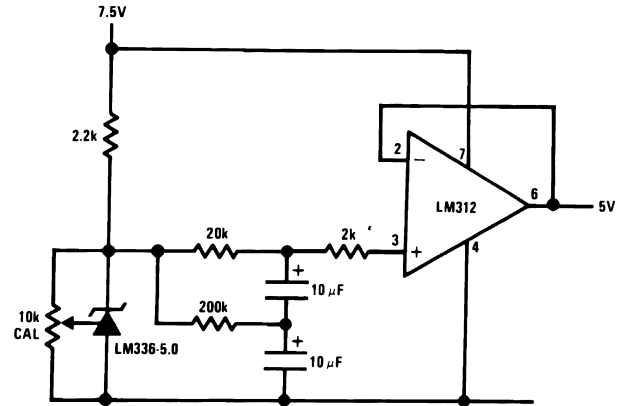

Schematic Diagram

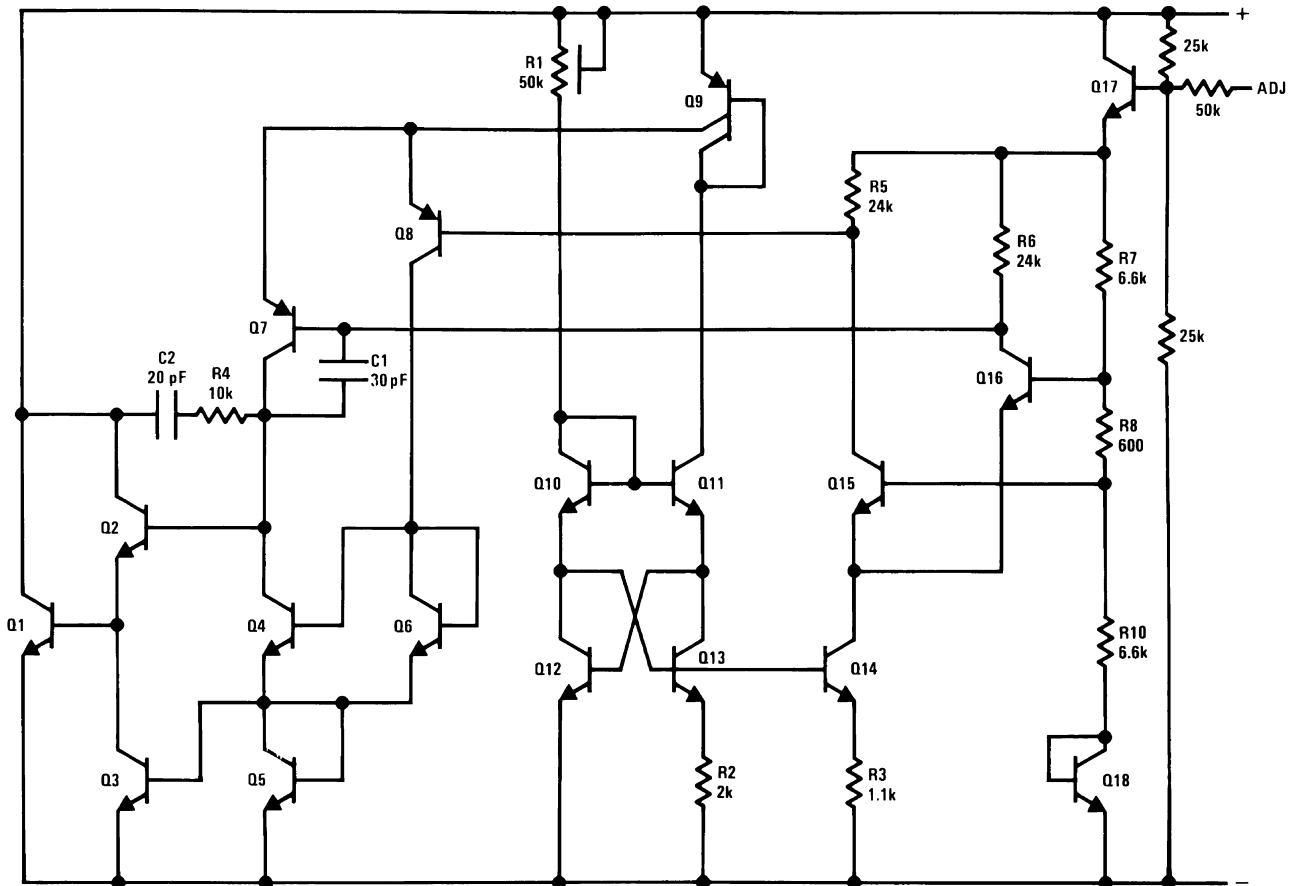

PACKAGE

SOP8

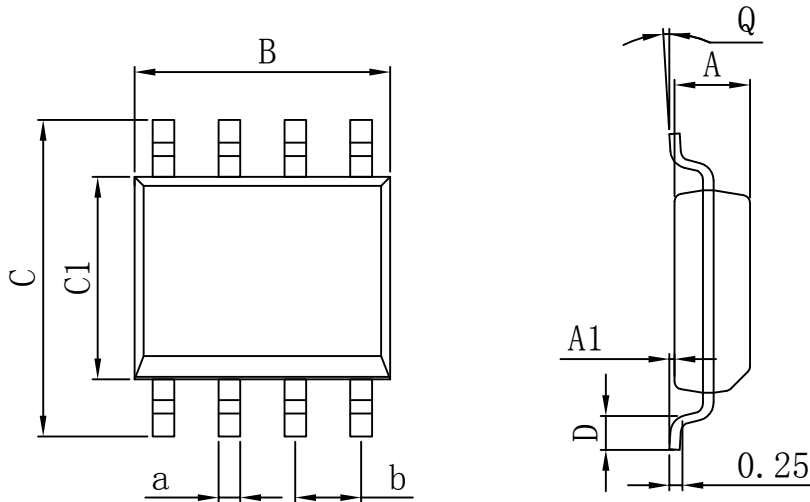

Dimensions In Millimeters					
Symbol :	Min :	Max :	Symbol :	Min :	Max :
A	1.225	1.570	D	0.400	0.950
A1	0.100	0.250	Q	0°	8°
B	4.800	5.100	a	0.420 TYP	
C	5.800	6.250	b	1.270 TYP	
C1	3.800	4.000			

TO-92

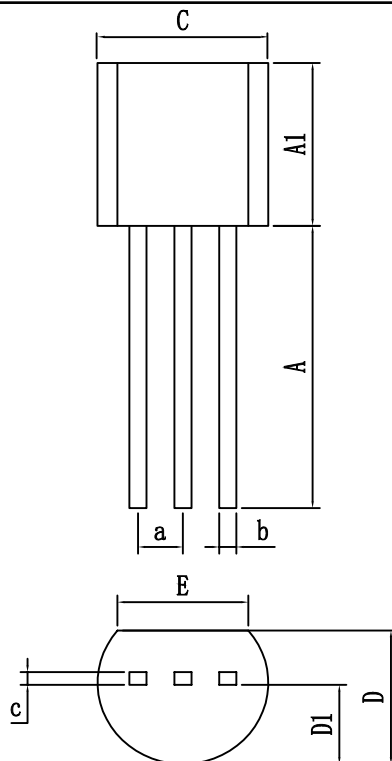

Dimensions In Millimeters					
Symbol :	Min :	Max :	Symbol :	Min :	Max :
A	11.200	12.700	E	3.430	3.830
A1	4.320	5.340	a	1.270 TYP	
C	4.440	5.210	b	0.485 TYP	
D	3.170	4.190	c	0.380 TYP	
D1	2.030	2.670			

PACKAGE

DFN-8(3*3)

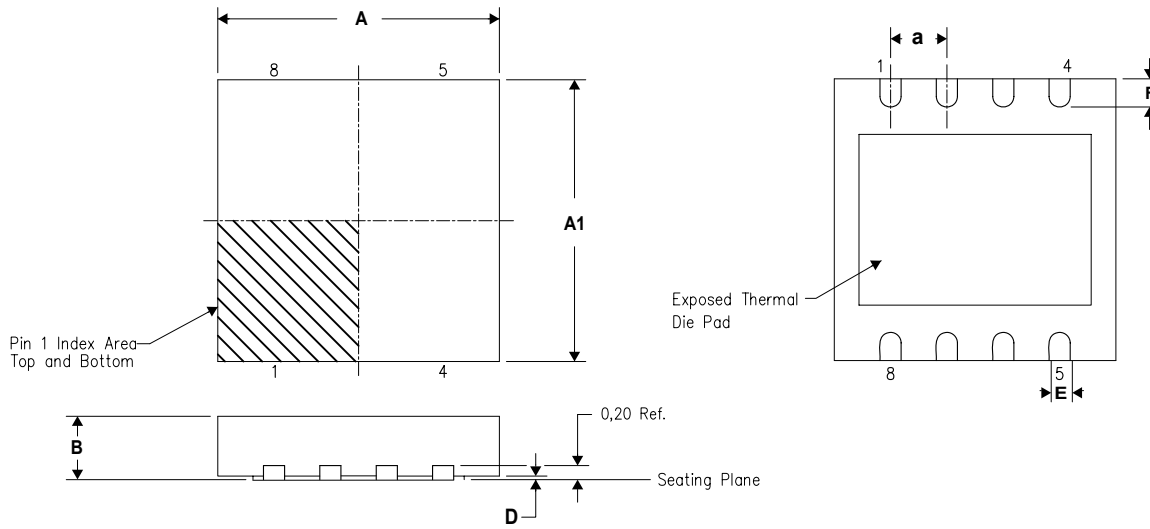

Dimensions In Millimeters					
Symbol :	Min :	Max :	Symbol :	Min :	Max :
A	2.900	3.100	E	0.200	0.340
A1	2.900	3.100	F	0.300	0.500
B	0.800	1.000	a	0.65 TYP	
D	0.000	0.050			

Important statement:

Huaguan Semiconductor Co,Ltd. reserves the right to change the products and services provided without notice. Customers should obtain the latest relevant information before ordering, and verify the timeliness and accuracy of this information.

Customers are responsible for complying with safety standards and taking safety measures when using our products for system design and machine manufacturing to avoid potential risks that may result in personal injury or property damage.

Our products are not licensed for applications in life support, military, aerospace, etc., so we do not bear the consequences of the application of these products in these fields.

Our documentation is only permitted to be copied without any tampering with the content, so we do not accept any responsibility or liability for the altered documents.

X-ON Electronics

Largest Supplier of Electrical and Electronic Components

Click to view similar products for [Voltage References](#) category:

Click to view products by [HGSEMI](#) manufacturer:

Other Similar products are found below :

[AS431ARTR-E1](#) [AZ431BR-ATRE1](#) [5962-8686103XC](#) [NCV431BVDMR2G](#) [SCV431AIDMR2G](#) [REF01J/883](#) [SC431ILPRAG](#) [AP432AQG-7](#) [LM4040B25QFTA](#) [TL431BL3T](#) [TL431ACZ](#) [KA431SLMF2TF](#) [KA431SMF2TF](#) [KA431SMFTF](#) [LM4040QCEM3-3.0/NOPB](#) [LM4041C12ILPR](#) [LM4050AIM3X-5.0/NOPB](#) [LM4120AIM5-2.5/NOP](#) [LM431SCCMFX](#) [ZXRE250BSA-7](#) [ZXRE125DN8TA](#) [TS3330AQPR](#) [ZXRE250ASA-7](#) [ZTL431ASE5TA](#) [ADR3512WCRMZ-R7](#) [REF3012AIDBZR](#) [LM385BM-2.5/NOPB](#) [LM385D-2.5R2G](#) [LM4040AIM3-10.0](#) [LM4040CIM3-10.0](#) [LM4040CIM3X-2.0/NOPB](#) [LM4041DH5TA](#) [LM4041QDIM3-ADJ/NO](#) [LM4051BIM3-ADJ/NOPB](#) [LM4051CIM3X-1.2/NOPB](#) [LM4128CMF-1.8/NOPB](#) [LM4132DMF-1.8/NOPB](#) [LM4132EMF-1.8/NOPB](#) [LM4132EMF-2.0/NOPB](#) [LM431CIM](#) [LM385BD-2.5R2G](#) [LM385M-2.5/NOPB](#) [LM4030AMF-4.096/NOPB](#) [LM4040D30ILPR](#) [AP432YG-13](#) [AP431IANTR-G1](#) [AP431AWG-7](#) [AS431ANTR-G1](#) [AS431AZTR-G1](#) [AS431BZTR-E1](#)