

## LM431A三端可调精密基准电路

### 概述 General Description

The LM431A is a three-terminal adjustable shunt regulator with guaranteed thermal stability over a full operation range. It features sharp turn-on characteristics, low temperature coefficient and low output impedance, which make it ideal substitute for Zener diode in applications such as switching power supply, charger and other adjustable regulators.

The output voltage of LM431A can be set to any value between  $V_{ref}$  (2.5V) and the corresponding maximum cathode voltage (40V). The LM431A is offered in two grade initial voltage tolerance at 25°C, 0.5% and 1.0%. This IC is available in 4 packages: SOP-8, TO-92 (bulk or ammo), SOT-23 and SOT-89.

LM431A 是三端可调的，全温度范围稳定的并联调整器。具有快速启动、低温漂和低输出阻抗的特性，在开关电源、充电和其他可调调整器应用中是齐纳二极管的理想替代器件。

输出电压范围为  $V_{ref}$  (2.5V) 到最大阴极电压 (36V)。0.5% 和 1.0% 两种精度 (25°C)。5 种封装：TO-92 (bulk 或 ammo)，SOT-23，SOP8 和 SOT-89。

### 特点 Features

- 可编程精确的输出电压：2.5V-36V  
Programmable Precise Output Voltage from 2.5V to 36V
- 低阴极电流：150uA(典型)  
Low Minimum Cathode Current for Regulation: 150uA(Typ.)
- 低温漂：5mV (典型)  
Low Temperature Deviation: 4mV Typical
- 电流能力：150uA--100mA  
Sink Current Capacity from 150uA to 100mA
- 低输出噪声 Low Output Noise
- 宽工作温度范围  
Wide Operating Range: -25°C to 125°C
- 任意容性负载下都能保证稳定工作  
Tolerates Capacitive Loads

### 应用 Applications

- 充电 Charger
- 电压适配器 Voltage Adapter
- 开关电源 Switching Power supply
- 图形卡 Graphic Card
- 精确电压基准 Precision Voltage Reference

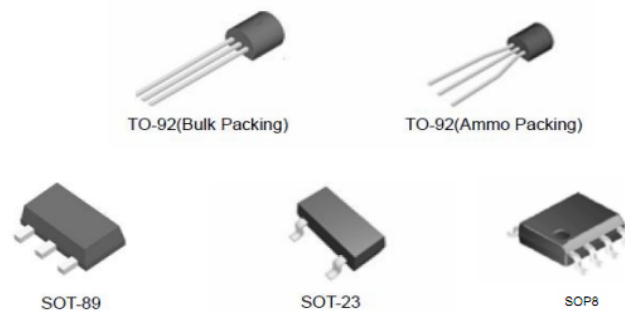
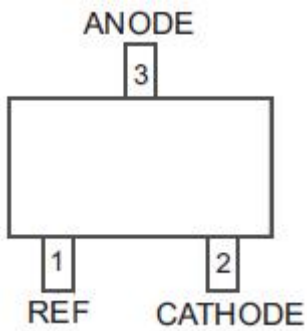

Figure 1. Package Type of LM431A

管脚排列 Pin Configuration

N Package  
(SOT-23)



P Package  
(SOT-89)

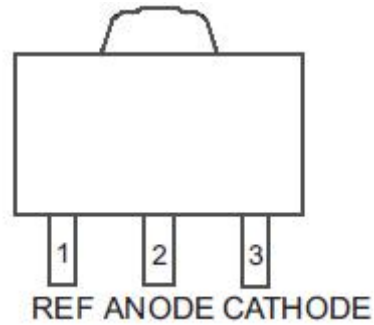

Z Package  
(TO-92(Bulk Package))

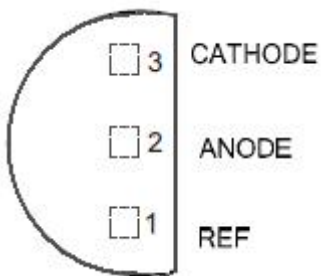

Z Package  
(TO-92(Ammo Package))

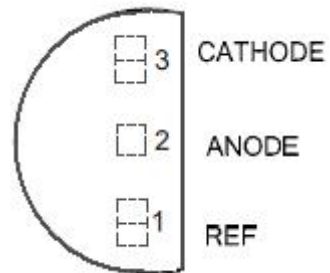

S8 Package  
(SOP8)

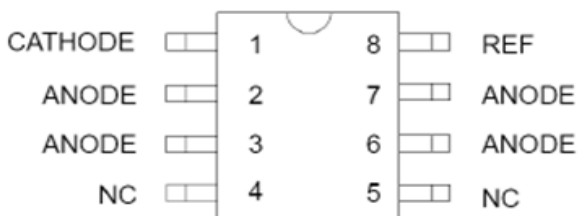

Figure 2. Pin Configuration of LM431A (Top View)

**功能框图 Functional Block Diagram**

Figure 3. Functional Block Diagram of LM431A

**绝对最大额定值 Absolute Maximum Rating (Note 1)**

项目 Parameter	符号 Symbol	数值 Value	单位 Unit
阴极电压 Cathode Voltage	$V_{KA}$	36	V
阴极电流范围 Cathode Current Range	$I_{KA}$	-100 to 150	mA
参考输入电流范围 Reference Input Current Range	$I_{REF}$	10	mA
结温 Junction Temperature	$T_j$	150	°C
存储温度 Storage Temperature Range	$T_{STG}$	-65 to 150	°C
ESD(人体模型) ESD(Human Body Model)	ESD	3500	V

**Note 1:** Stresses greater than those listed under “Absolute Maximum Ratings” may cause permanent

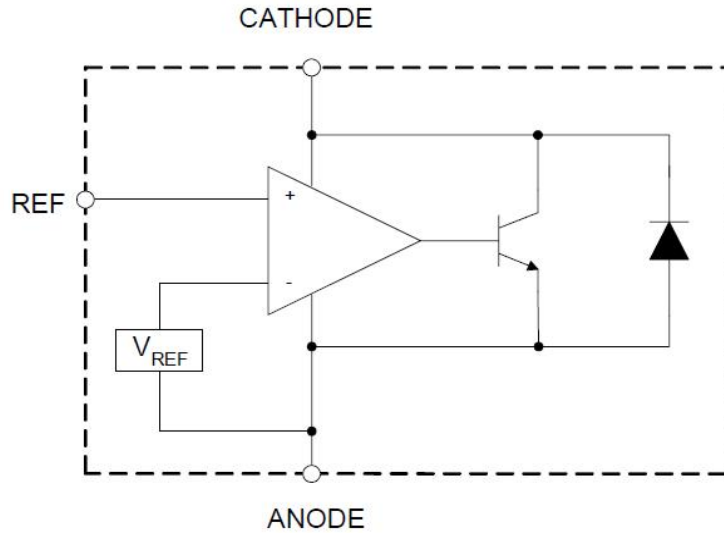
damage to the device. These are stress ratings only, and functional operation of the device at these or any other conditions beyond those indicated under “Recommended Operating Conditions” is not implied. Exposure to “Absolute Maximum Ratings” for extended periods may affect device reliability.

**备注 1：**超过“绝对最大额定值”的应力可能会造成器件永久损坏。这些仅是应力额定值，器件工作在上述条件以及超出“建议工作条件”的情况是不可取的。长期处于“绝对最大额定值”可能影响器件的可靠性。

## 环境温度下的额定功耗 Dissipation Rating - Free-air Temperature(Note 2)

Package	Ta=25°C Power Rating
SOP-8	770mW
TO-92	700mW
SOT-89	500mW
SOT-23	230mW

**Note 2：**The safe-work power dissipation of LM431A is under 0.25W while the package is TO -92 which is the ordinary transistor package. Above the power dissipation, the package should be changed to SO or DIP and the dissipation can be to 0.5W. The margin of power should be enough large because the reference voltage will falls as large power dissipation and high temperature rising. LM431A only is a reference voltage source. It is used to output a stable reference voltage, not large power.

**备注 2：**LM431A 的安全使用功率一般设计在 0.25W 以下（TO-92 封装，也就是普通小三极管封装），如果要较大的功率，你可以考虑一下 SO 封装或 DIP 封装的，这两种封装的功率设计为 0.5W 也很稳定。给 LM431A 留的功率余量较大，是考虑到 LM431A 在大功率，高温升的情况下稳压进度会下降。LM431A 只是一种基准电压源，它的最大作用是提供稳定的基准电压，而不是输出大功率。

## 推荐工作条件 Recommended Operating Conditions

项目 Parameter	符号 Symbol	最小值 Min	最大值 Max	单位 Unit
阴极电压 Cathode Voltage	$V_{KA}$	$V_{REF}$	36	V
阴极电流 Cathode Current	$I_{KA}$	0.2	100	mA
工作环境温度 Operating Ambient Temperature Range	$T_A$	-25	125	°C

## 电特性表 Electrical Characteristics

 Operating Conditions:  $T_A=25^{\circ}\text{C}$ , unless otherwise specified

 工作条件：除非特指，环境温度  $25^{\circ}\text{C}$ 

项目 Parameter		测试 电路 Test Circuit	符号 Symbol	测试条件 Conditions	数值 Value			单位 Unit
					最小 Min	典型 Typ	最大 Max	
参考电压 Reference Voltage	0.5%	4	$V_{REF}$	$V_{KA}=V_{REF}$ $I_{KA}=10\text{mA}$	2.487	2.500	2.513	V
	1.0%				2.475	2.500	2.525	
基准电压温漂 Deviation of Reference Voltage Over Full Temperature Range		4	$\Delta V_{REF}$	$V_{KA}=V_{REF}$ $I_{KA}=10\text{mA}$ $-20^{\circ}\text{C}$ to $110^{\circ}\text{C}$		-5	-20	mV
基准电压的线性调整率 Ratio of Change in Reference Voltage to the Change in Cathode Voltage		5	$\frac{\Delta V_{REF}}{\Delta V_{KA}}$	$I_{KA}=10\text{mA}$ $V_{KA}=10\text{V}$ to $V_{REF}$		-1.87		mV/V
				$I_{KA}=10\text{mA}$ $V_{KA}=36\text{V}$ to $10\text{V}$		-1.38		
基准电流 Reference Current		5	$I_{REF}$	$I_{KA}=10\text{mA}$ $R_1=10\text{K}\Omega$ $R_2=\infty$		0.3	0.6	$\mu\text{A}$
基准电流温漂 Deviation of Reference Current Over Full Temperature Range		5	$\Delta I_{REF}$	$I_{KA}=10\text{mA}$ $R_1=10\text{K}\Omega$ $R_2=\infty$ $T_A=-10^{\circ}\text{C}$ to $85^{\circ}\text{C}$		0.2	0.3	$\mu\text{A}$
最小阴极电流 Minimum Cathode Current for Regulation		4	$I_{KA}(\text{Min})$	$V_{KA}=V_{REF}$		150	400	$\mu\text{A}$
夹断阴极电流 Off-state Cathode Current		6	$I_{KA}(\text{Off})$	$V_{KA}=36\text{V}$ $V_{REF}=0$		0.01	1	$\mu\text{A}$
动态阻抗 Dynamic Impedance		4	$Z_{KA}$	$V_{KA}=V_{REF}$ $I_{KA}=1$ to $100\text{mA}$ $f \leq 1.0\text{KHz}$		0.1	0.5	$\Omega$
热阻 Thermal Resistance			$\theta_{JC}$	TO-92		68		$^{\circ}\text{C}/\text{W}$
				SOT-89		70		
				SOT-23		113		
				SOP-8		150		

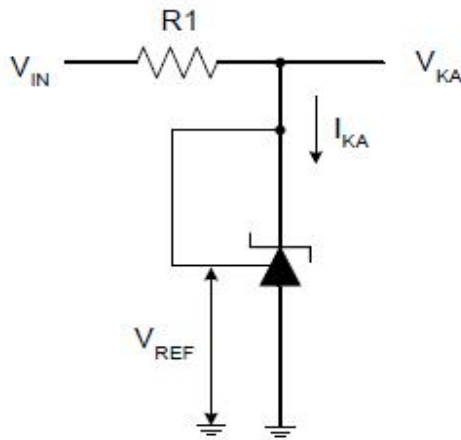

Figure 4. Test Circuit 4 for  $V_{KA}=V_{REF}$

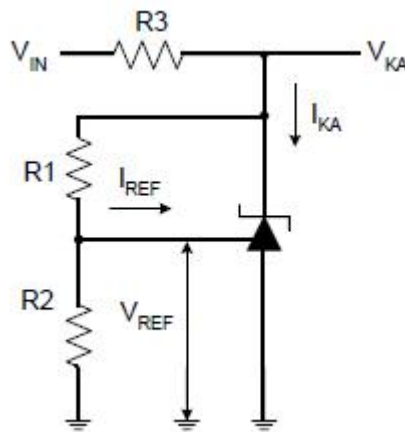

Figure 5. Test Circuit 5 for  $V_{KA}=V_{REF}(1+R_1/R_2)+I_{REF}*R_1$

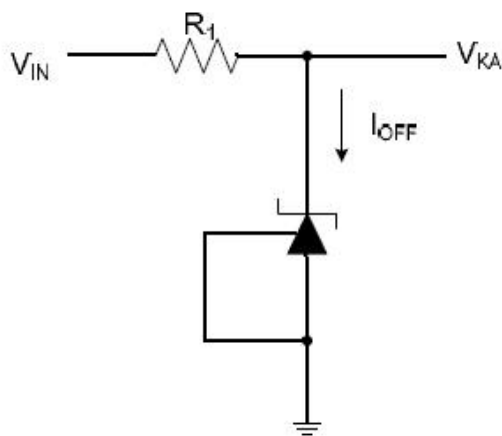

Figure 6. Test Circuit 6 for  $I_{OFF}$

典型性能 Typical Performance Characteristic

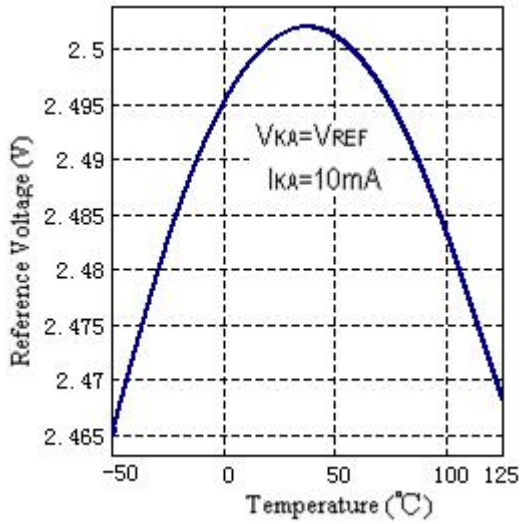

Figure 7. Reference Voltage vs. Ambient Temperature

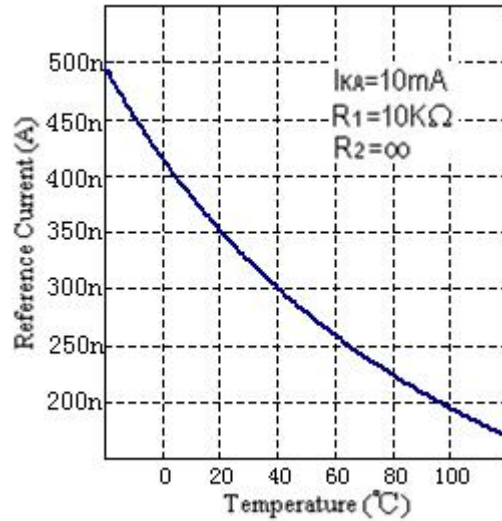

Figure 8. Reference Current vs. Ambient Temperature

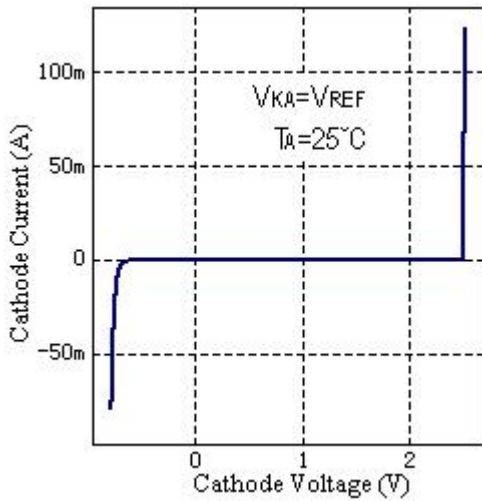

Figure 9. Cathode Current vs. Cathode Voltage

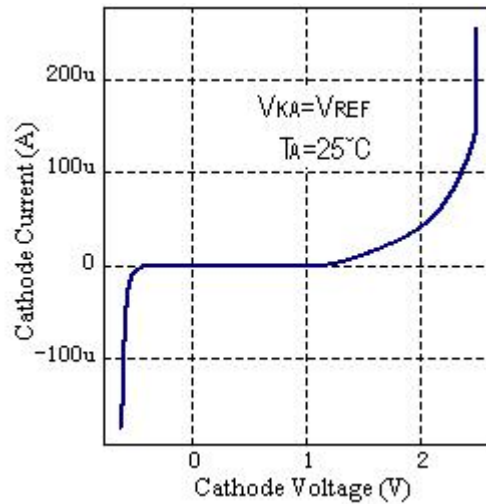

Figure 10. Cathode Current vs. Cathode Voltage

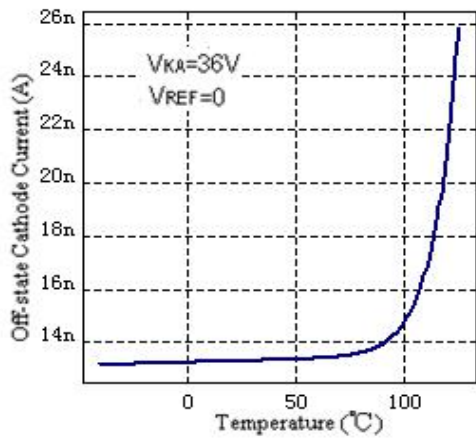

Figure 11. Off-state Cathode Current vs. Ambient Temperature

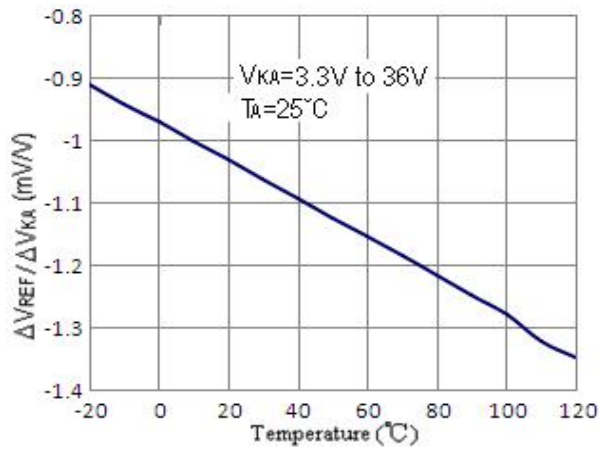

Figure 12. Ratio of Delta Reference Voltage to the Ratio of Delta Cathode Voltage

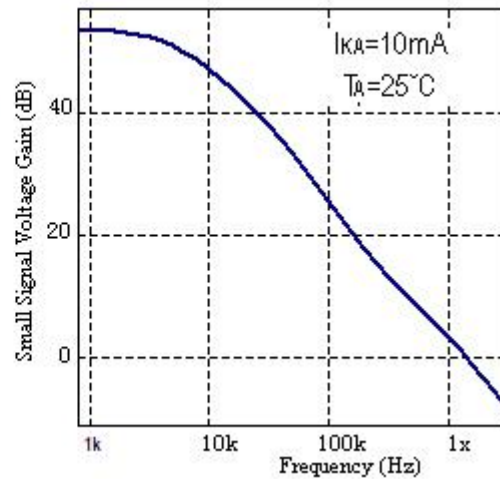
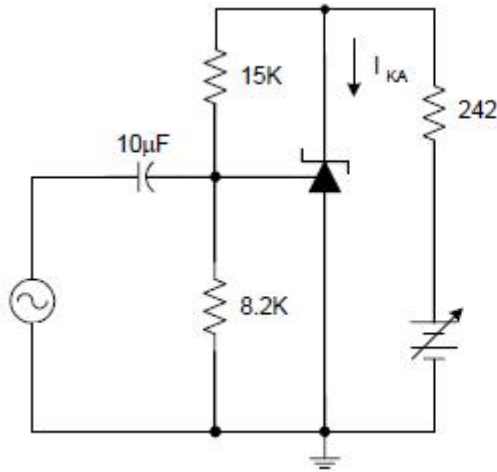

Figure 13. Small Signal Voltage Gain vs. Frequency

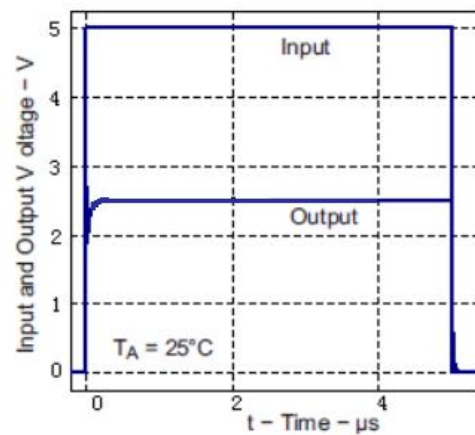
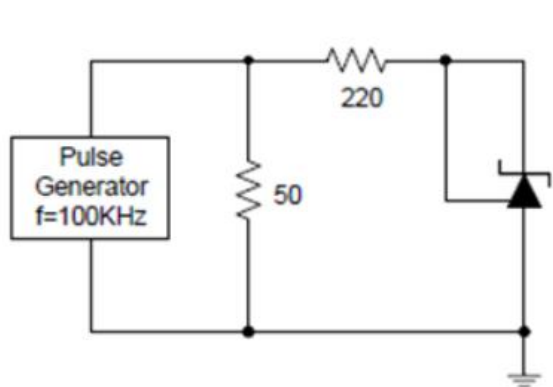

Figure 14. Pulse Response of Input and Output Voltage



典型应用 Typical Application

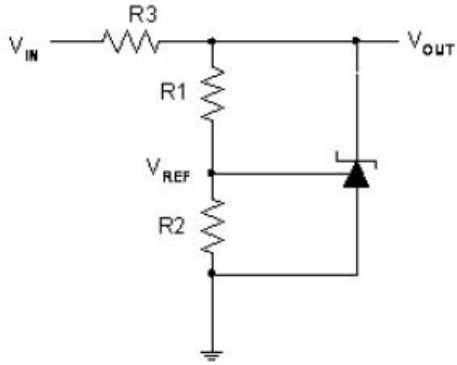

Figure 15. Shunt Regulator

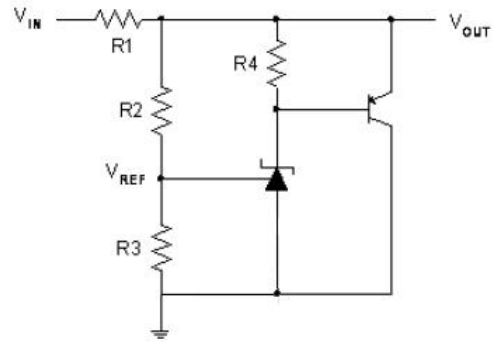

Figure 16. High Current Shunt Regulator

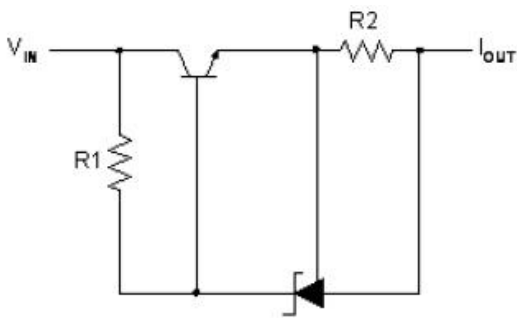

Figure 17. Current Source or Current Limit

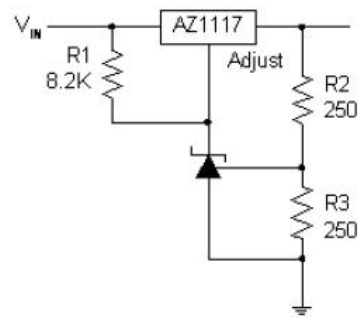

Figure 18. Precision 5V 1A Regulator

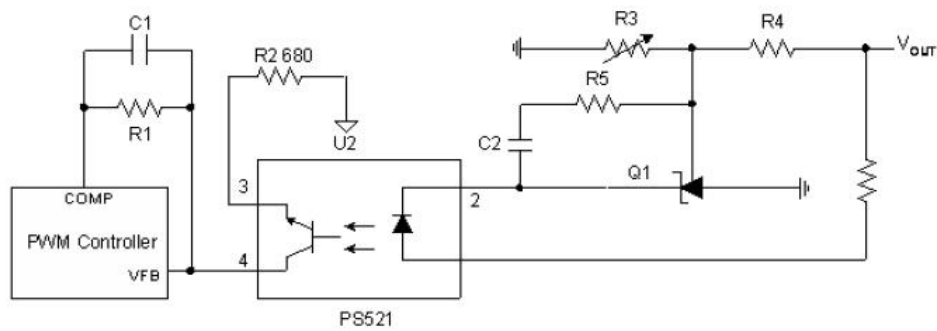

Figure 19. PWM Converter with Reference

**重要声明：**

华冠半导体保留未经通知更改所提供的产品和服务。客户在订货前应获取最新的相关信息，并核实这些信息是否最新且完整的。

客户在使用华冠半导体产品进行系统设计和整机制造时有责任遵守安全标准并采取安全措施，以避免潜在风险可能导致人身伤害或财产损失情况的发生。

华冠半导体产品未获得生命支持、军事、航空航天等领域应用之许可，华冠半导体将不承担产品在这些领域应用造成的后果。

华冠半导体的文档资料，仅在没有对内容进行任何篡改且带有相关授权的情况下才允许进行复制。华冠半导体对篡改过的文件不承担任何责任或义务。

## X-ON Electronics

Largest Supplier of Electrical and Electronic Components

*Click to view similar products for [Voltage References](#) category:*

*Click to view products by [HGSEMI](#) manufacturer:*

Other Similar products are found below :

[622664A](#) [636116E](#) [748389C](#) [AS431ARTR-E1](#) [NCP431BCSNT1G](#) [NCP432BCSNT1G](#) [NCV431BSNT1G](#) [AP4313UKTR-G1](#)  
[TL1431AIYDT](#) [AZ431BR-ATRE1](#) [622668D](#) [NCP432BVSNT1G](#) [5962-8686103XC](#) [NCV431BVDMR2G](#) [AZ432BNTR-G1](#)  
[AP4306BUKTR-G1](#) [SC431BVSNT1G](#) [MAX6023EBT30+T](#) [NCV431ASNT1G](#) [LM4040CEM3-5.0/V+T](#) [LT1460KCS3-3#TRM](#)  
[LT1460KCS3-3.3#TRM](#) [LT6660KCDC-10#TRMPBF](#) [LTC6652BHLS8-5#PBF](#) [LTC6652AHLS8-4.096#PBF](#) [LTC6655BHLS8-4.096#PBF](#)  
[LT6660HCDC-5#TRMPBF](#) [LM336Z-2.5#PBF](#) [LT1021BMH-10](#) [SC431ILPRAG](#) [TLVH431MIL3T](#) [MAX6023EBT21+T](#) [AP432AQG-7](#)  
[ADR4540CRZ](#) [LM4040B25QFTA](#) [TS3325AQPR](#) [REF102AU/2K5](#) [TL4050B25QDBZR](#) [TL4051C12QDCKR](#) [TL431ACZ](#) [KA431SLMF2TF](#)  
[KA431SMF2TF](#) [KA431SMFTF](#) [LM385BXZ/NOPB](#) [LM4040QCEM3-3.0/NOPB](#) [LM4041C12ILPR](#) [LM4050AEM3X-5.0/NOPB](#)  
[LM4050AIM3X-5.0/NOPB](#) [LM4120AIM5-2.5/NOP](#) [LM431SCCMFX](#)