

1MHZ CMOS Rail-to-Rail IO Opamp with RF Filter

Features

- Single-Supply Operation from +2.1V ~ +5.5V
- Rail-to-Rail Input / Output
- Gain-Bandwidth Product: 1MHz (Typ.)
- Low Input Bias Current: 1pA (Typ.)
- Low Offset Voltage: 3.5mV (Max.)
- Quiescent Current: 40μA per Amplifier (Typ.)
- Operating Temperature: -40°C ~ +125°C
- Embedded RF Anti-EMI Filter
- Small Package:
- LMV321 Available in SOT23-5 and SC70-5 Packages
- LMV358 Available in SOP-8, MSOP-8, DIP-8 and DFN-8 Packages
- LMV324 Available in SOP-14 and TSSOP-14 Packages

General Description

The LMV321 family have a high gain-bandwidth product of 1MHz, a slew rate of 0.6V/μs, and a quiescent current of 40 μA/amplifier at 5V. The LMV321 family is designed to provide optimal performance in low voltage and low noise systems. They provide rail-to-rail output swing into heavy loads. The input common mode voltage range includes ground, and the maximum input offset voltage is 3.5mV for LMV321 family. They are specified over the extended industrial temperature range (-40°C to +125°C). The operating range is from 2.1V to 5.5V. The LMV321 single is available in Green SC70-5 and SOT-23-5 packages. The LMV358 Dual is available in Green SOP-8, MSOP-8, DIP-8 and DFN-8 packages. The LMV324 Quad is available in Green SOP-14 and TSSOP-14 packages.

Applications

- ASIC Input or Output Amplifier
- Sensor Interface
- Medical Communication
- Smoke Detectors
- Audio Output
- Piezoelectric Transducer Amplifier
- Medical Instrumentation
- Portable Systems

Pin Configuration

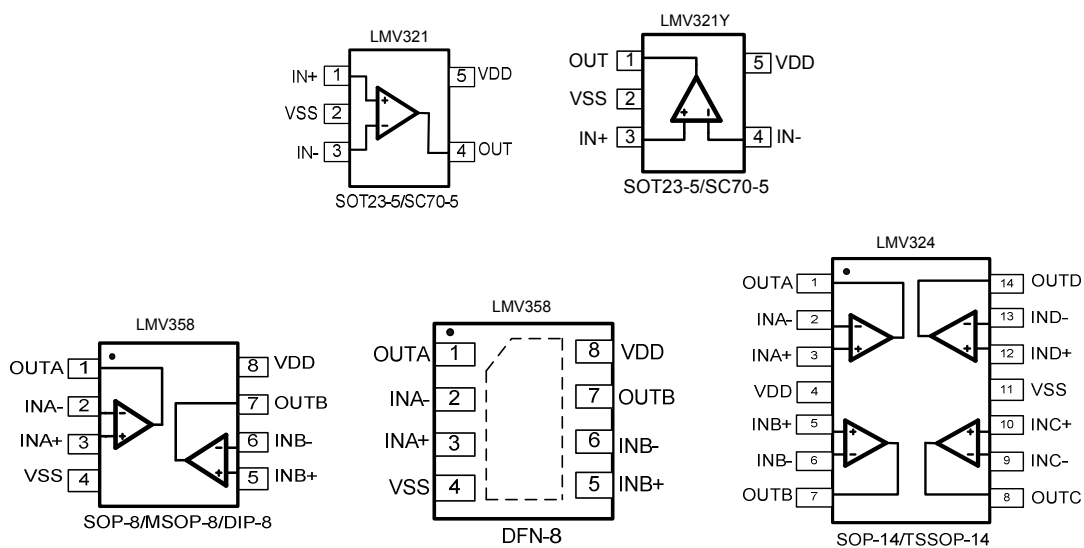

Figure 1. Pin Assignment Diagram

Absolute Maximum Ratings

Condition	Min	Max
Power Supply Voltage (V_{DD} to V_{SS})	-0.5V	+7.5V
Analog Input Voltage (IN+ or IN-)	$V_{SS}-0.5V$	$V_{DD}+0.5V$
PDB Input Voltage	$V_{SS}-0.5V$	+7V
Operating Temperature Range	-40°C	+125°C
Junction Temperature	+160°C	
Storage Temperature Range	-55°C	+150°C
Lead Temperature (soldering, 10sec)	+260°C	
Package Thermal Resistance ($T_A=+25^\circ\text{C}$)		
SOP-8, θ_{JA}	125°C/W	
MSOP-8, θ_{JA}	216°C/W	
SOT23-5, θ_{JA}	190°C/W	
SC70-5, θ_{JA}	333°C/W	
ESD Susceptibility		
HBM	6KV	
MM	300V	

Note: Stress greater than those listed under Absolute Maximum Ratings may cause permanent damage to the device. This is a stress rating only and functional operation of the device at these or any other conditions outside those indicated in the operational sections of this specification are not implied. Exposure to absolute maximum rating conditions for extended periods may affect reliability.

Electrical Characteristics

(At $V_S = +5V$, $R_L = 100k\Omega$ connected to $V_S/2$, and $V_{OUT} = V_S/2$, unless otherwise noted.)

PARAMETER	SYMBOL	CONDITIONS	LMV321/358/324				
			TYP	MIN/MAX OVER TEMPERATURE			
			+25°C	+25°C	-40°C to +85°C	UNITS	MIN/MAX
INPUT CHARACTERISTICS							
Input Offset Voltage	V_{OS}	$V_{CM} = V_S/2$	0.4	3.5	5.6	mV	MAX
Input Bias Current	I_B		1			pA	TYP
Input Offset Current	I_{OS}		1			pA	TYP
Common-Mode Voltage Range	V_{CM}	$V_S = 5.5V$	-0.1 to +5.6			V	TYP
Common-Mode Rejection Ratio	CMRR	$V_S = 5.5V, V_{CM} = -0.1V$ to 4V	70	62	62	dB	MIN
		$V_S = 5.5V, V_{CM} = -0.1V$ to 5.6V	68	56	55		
Open-Loop Voltage Gain	A_{OL}	$R_L = 5k\Omega, V_O = +0.1V$ to +4.9V	80	70	70	dB	MIN
		$R_L = 10k\Omega, V_O = +0.1V$ to +4.9V	100	90	85		
Input Offset Voltage Drift	$\Delta V_{OS}/\Delta T$		2.7			$\mu V/^\circ C$	TYP
OUTPUT CHARACTERISTICS							
Output Voltage Swing from Rail	V_{OH}	$R_L = 100k\Omega$	4.997	4.990	4.980	V	MIN
	V_{OL}	$R_L = 100k\Omega$	3	10	20	mV	MAX
	V_{OH}	$R_L = 10k\Omega$	4.992	4.970	4.960	V	MIN
	V_{OL}	$R_L = 10k\Omega$	8	30	40	mV	MAX
Output Current	I_{SOURCE}	$R_L = 10\Omega$ to $V_S/2$	84	60	45	mA	MIN
	I_{SINK}		75	60	45		
POWER SUPPLY							
Operating Voltage Range				2.1	2.5	V	MIN
				5.5	5.5	V	MAX
Power Supply Rejection Ratio	PSRR	$V_S = +2.5V$ to +5.5V, $V_{CM} = +0.5V$	82	60	58	dB	MIN
Quiescent Current / Amplifier	I_Q		40	60	80	μA	MAX
DYNAMIC PERFORMANCE (CL = 100pF)							
Gain-Bandwidth Product	GBP		1			MHz	TYP
Slew Rate	SR	$G = +1, 2V$ Output Step	0.6			V/ μs	TYP
Settling Time to 0.1%	t_S	$G = +1, 2V$ Output Step	5			μs	TYP
Overload Recovery Time		$V_{IN} \cdot Gain = V_S$	2.6			μs	TYP
NOISE PERFORMANCE							
Voltage Noise Density	e_n	f = 1kHz	27			nV/\sqrt{Hz}	TYP
		f = 10kHz	20			nV/\sqrt{Hz}	TYP

Typical Performance characteristics

At $T_A=+25^{\circ}\text{C}$, $V_S=+5\text{V}$, and $R_L=100\text{K}\Omega$ connected to $V_S/2$, unless otherwise noted.

Large-Signal Step Response

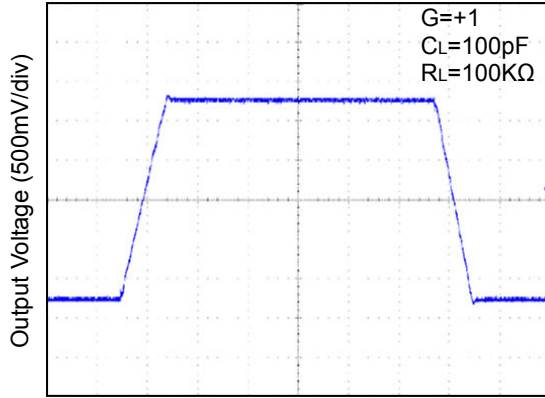

Time (4µs/div)

Small-Signal Step Response

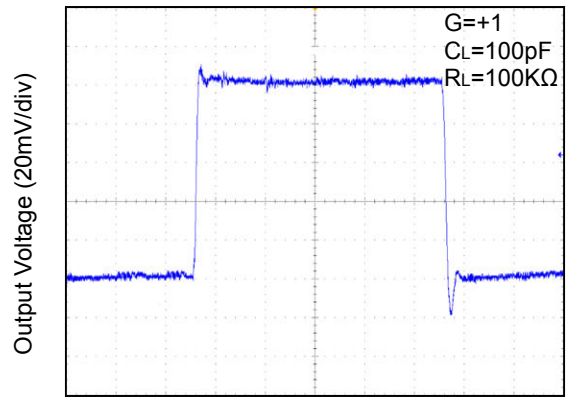

Time (2µs/div)

Supply Current vs. Supply Voltage

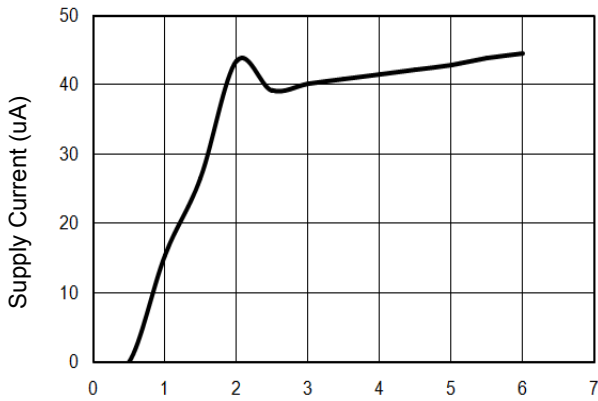

Supply Voltage (V)

Short-Circuit Current vs. Supply Voltage



Supply Voltage (V)

Output Voltage vs. Output Current

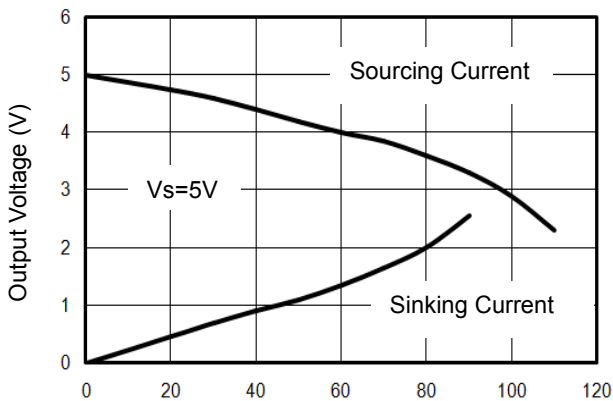

Output Current (mA)

Output Voltage vs. Output Current

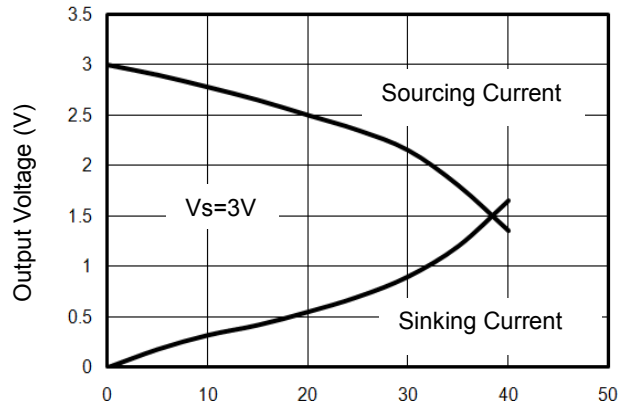

Output Current (mA)

Typical Performance characteristics

At $T_A=+25^{\circ}\text{C}$, $V_S=+5\text{V}$, and $R_L=100\text{K}\Omega$ connected to $V_S/2$, unless otherwise noted.

Overload Recovery Time

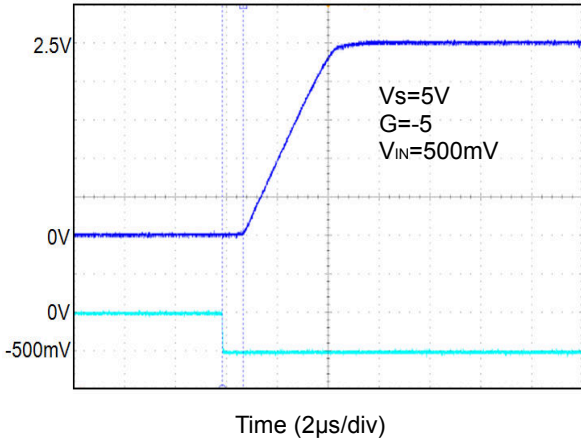

Supply Current vs. Temperature

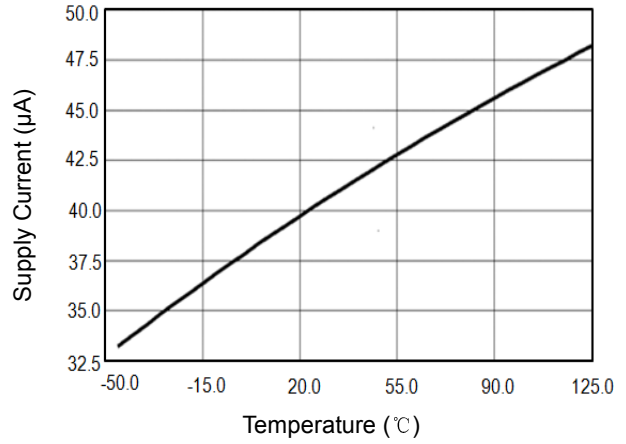

Input Voltage Noise Spectral Density vs. Frequency

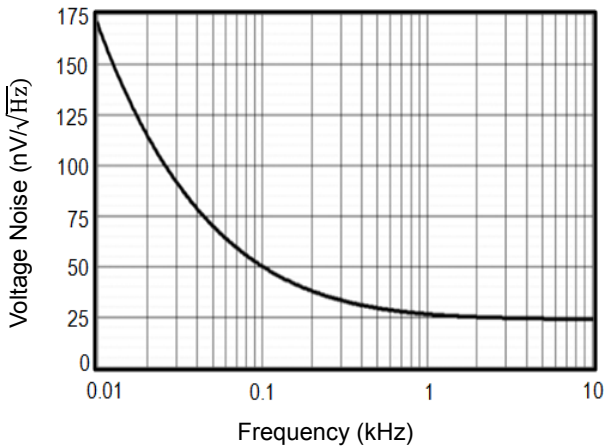

Open Loop Gain, Phase Shift vs. Frequency at +5V

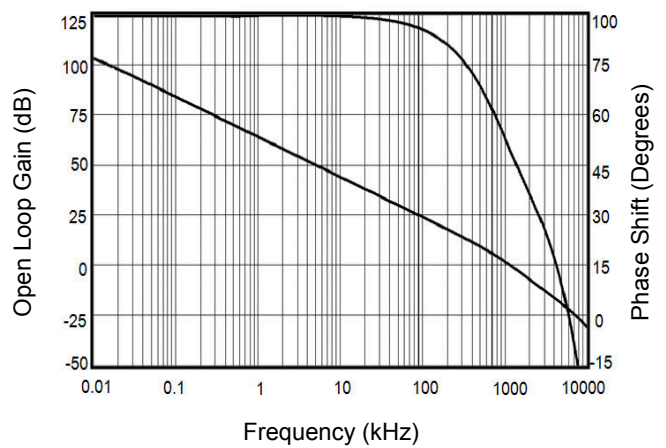

CMRR vs. Frequency

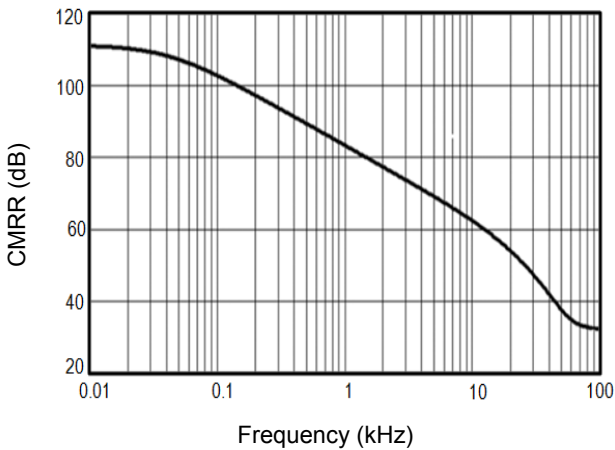

PSRR vs. Frequency

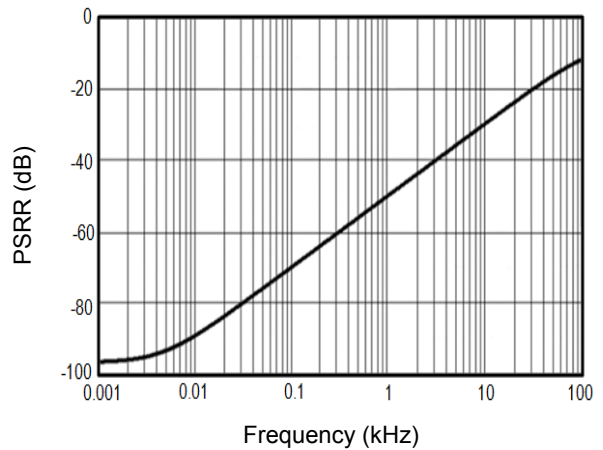

Application Note

Size

LMV321 family series op amps are unity-gain stable and suitable for a wide range of general-purpose applications. The small footprints of the LMV321 family packages save space on printed circuit boards and enable the design of smaller electronic products.

Power Supply Bypassing and Board Layout

LMV321 family series operates from a single 2.1V to 5.5V supply or dual $\pm 1.05\text{V}$ to $\pm 2.75\text{V}$ supplies. For best performance, a $0.1\mu\text{F}$ ceramic capacitor should be placed close to the V_{DD} pin in single supply operation. For dual supply operation, both V_{DD} and V_{SS} supplies should be bypassed to ground with separate $0.1\mu\text{F}$ ceramic capacitors.

Low Supply Current

The low supply current (typical $40\mu\text{A}$ per channel) of LMV321 family will help to maximize battery life. They are ideal for battery powered systems

Operating Voltage

LMV321 family operates under wide input supply voltage (2.1V to 5.5V). In addition, all temperature specifications apply from -40°C to $+125^\circ\text{C}$. Most behavior remains unchanged throughout the full operating voltage range. These guarantees ensure operation throughout the single Li-Ion battery lifetime

Rail-to-Rail Input

The input common-mode range of LMV321 family extends 100mV beyond the supply rails ($V_{\text{SS}}-0.1\text{V}$ to $V_{\text{DD}}+0.1\text{V}$). This is achieved by using complementary input stage. For normal operation, inputs should be limited to this range.

Rail-to-Rail Output

Rail-to-Rail output swing provides maximum possible dynamic range at the output. This is particularly important when operating in low supply voltages. The output voltage of LMV321 family can typically swing to less than 5mV from supply rail in light resistive loads ($>100\text{k}\Omega$), and 30mV of supply rail in moderate resistive loads ($10\text{k}\Omega$).

Capacitive Load Tolerance

The LMV321 family is optimized for bandwidth and speed, not for driving capacitive loads. Output capacitance will create a pole in the amplifier's feedback path, leading to excessive peaking and potential oscillation. If dealing with load capacitance is a requirement of the application, the two strategies to consider are (1) using a small resistor in series with the amplifier's output and the load capacitance and (2) reducing the bandwidth of the amplifier's feedback loop by increasing the overall noise gain. Figure 2. shows a unity gain follower using the series resistor strategy. The resistor isolates the output from the capacitance and, more importantly, creates a zero in the feedback path that compensates for the pole created by the output capacitance.

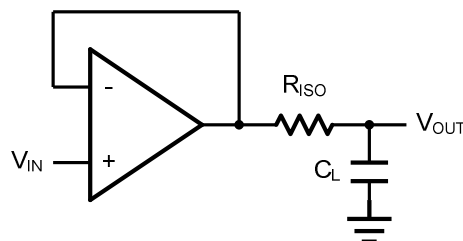

Figure 2. Indirectly Driving a Capacitive Load Using Isolation Resistor

The bigger the R_{ISO} resistor value, the more stable V_{OUT} will be. However, if there is a resistive load R_{L} in parallel with the capacitive load, a voltage divider (proportional to $R_{\text{ISO}}/R_{\text{L}}$) is formed, this will result in a gain error.

The circuit in Figure 3 is an improvement to the one in Figure 2. R_{F} provides the DC accuracy by feed-forward the V_{IN} to R_{L} . C_{F}

and R_{ISO} serve to counteract the loss of phase margin by feeding the high frequency component of the output signal back to the amplifier's inverting input, thereby preserving the phase margin in the overall feedback loop. Capacitive drive can be increased by increasing the value of C_F . This in turn will slow down the pulse response.

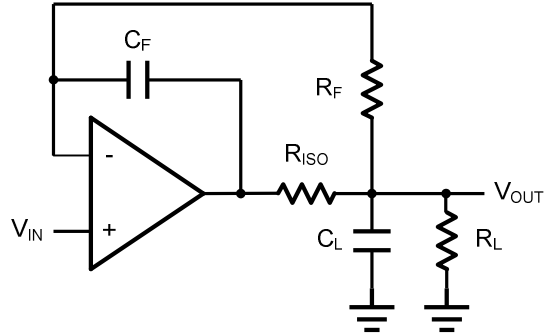

Figure 3. Indirectly Driving a Capacitive Load with DC Accuracy

Typical Application Circuits

Differential amplifier

The differential amplifier allows the subtraction of two input voltages or cancellation of a signal common the two inputs. It is useful as a computational amplifier in making a differential to single-end conversion or in rejecting a common mode signal. Figure 4. shown the differential amplifier using LMV321 family.

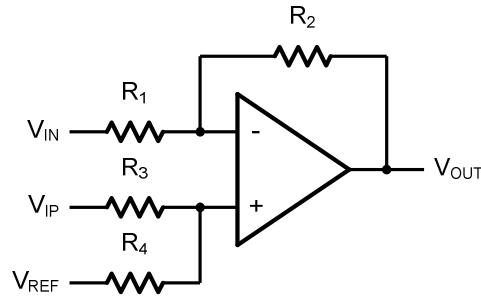

Figure 4. Differential Amplifier

$$V_{OUT} = \left(\frac{R_1+R_2}{R_3+R_4}\right) \frac{R_4}{R_1} V_{IN} - \frac{R_2}{R_1} V_{IP} + \left(\frac{R_1+R_2}{R_3+R_4}\right) \frac{R_3}{R_1} V_{REF}$$

If the resistor ratios are equal (i.e. $R_1=R_3$ and $R_2=R_4$), then

$$V_{OUT} = \frac{R_2}{R_1} (V_{IP} - V_{IN}) + V_{REF}$$

Low Pass Active Filter

The low pass active filter is shown in Figure 5. The DC gain is defined by $-R_2/R_1$. The filter has a -20dB/decade roll-off after its corner frequency $f_C=1/(2\pi R_3 C_1)$.

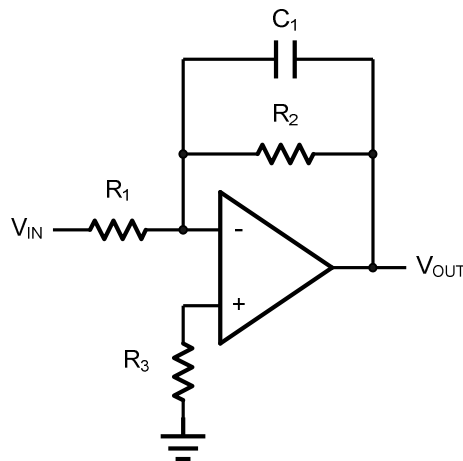

Figure 5. Low Pass Active Filter

Instrumentation Amplifier

The triple LMV321 family can be used to build a three -op-amp instrumentation amplifier as shown in Figure 6. The amplifier in Figure 6 is a high input impedance differential amplifier with gain of R_2/R_1 . The two differential voltage followers assure the high input impedance of the amplifier.

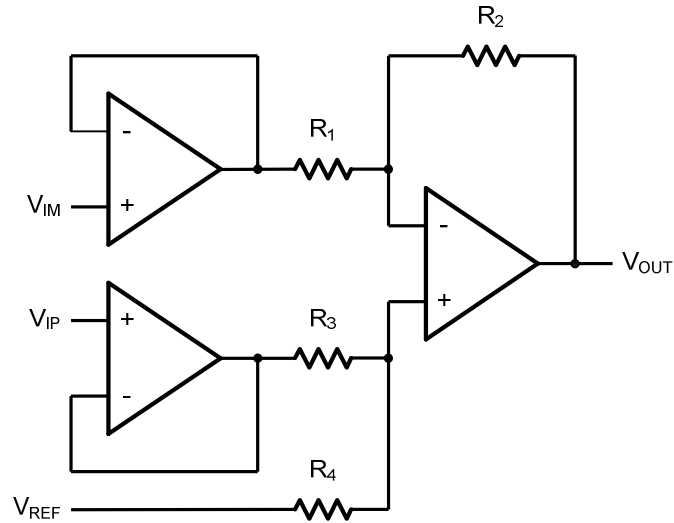

Figure 6. Instrument Amplifier

X-ON Electronics

Largest Supplier of Electrical and Electronic Components

Click to view similar products for [Operational Amplifiers - Op Amps](#) category:

Click to view products by [HGSEMI](#) manufacturer:

Other Similar products are found below :

[LM358SNG](#) [430227FB](#) [AZV831KTR-G1](#) [LT1678IS8](#) [042225DB](#) [058184EB](#) [SC2902DG](#) [UPC822G2-A](#) [UPC258G2-A](#) [MIC918YC5-TR](#)
[NCS5651MNTXG](#) [NCV33202DMR2G](#) [NJM324E](#) [NTE925](#) [5962-9080901MCA*](#) [AP4310AUMTR-AG1](#) [HA1630D02MMEL-E](#)
[HA1630S01LPEL-E](#) [SCY33178DR2G](#) [NJU77806F3-TE1](#) [NCV5652MUTWG](#) [NCV20034DR2G](#) [LM2902EDR2G](#) [NTE778S](#) [NTE871](#)
[NTE924](#) [NTE937](#) [MCP6V16UT-E/OT](#) [MCP6V17T-E/MS](#) [MCP6V19T-E/ST](#) [SCY6358ADR2G](#) [NCS20282FCTTAG](#) [UPC4741G2-E1-A](#)
[LM4565FVT-GE2](#) [EL5420CRZ-T7A](#) [TSV791IYLT](#) [TSV772IQ2T](#) [AS324AMTR-E1](#) [TLV2772QPWR](#) [NJM4556AM-TE1](#) [NJM2068M-TE1](#)
[AS324MTR-E1](#) [AS358MMTR-G1](#) [MCP6232T-EMNY](#) [MCP662-E/MF](#) [TLC081AIP](#) [TLC082AIP](#) [TLE2074ACDW](#) [TLV07IDR](#)
[TLV2170IDGKT](#)