

7ns 2.7V to 5V Comparator with Rail-to-Rail Output

Features

- (VS = 5 V, TA = 25°C, Typical Values Unless Specified)
- Propagation Delay 7 ns
- Low Supply Current 1.1 mA
- Input Common Mode Voltage Range Extends 200 mV Below Ground
- Ideal for 2.7-V and 5-V Single Supply Applications
- Internal Hysteresis Ensures Clean Switching
- Fast Rise and Fall Time 1.3 ns
- Available in Space-saving Packages: SC-70 and SOT-23
- Supports 105°C PCB Temperature

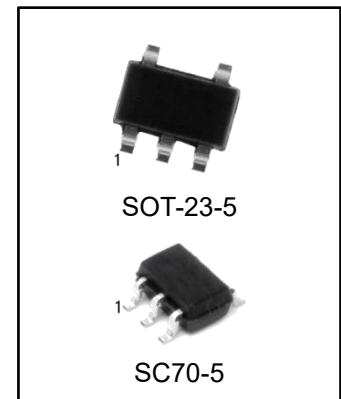

Ordering Information

DEVICE	Package Type	MARKING	Packing	Packing Qty
LMV7219M5/TR	SOT-23-5	V7219,C14A	REEL	3000pcs/reel
LMV7219M7/TR	SC70-5	V7219,C15	REEL	3000pcs/reel

Description

The LMV7219 is a low-power, high-speed comparator with internal hysteresis. The LMV7219 operating voltage ranges from 2.7 V to 5 V with push-pull rail-to-rail output. This device achieves a 7-ns propagation delay while consuming only 1.1 mA of supply current at 5 V.

The LMV7219 inputs have a common mode voltage range that extends 200 mV below ground, allowing ground sensing. The internal hysteresis ensures clean output transitions even with slow-moving input signals.

The LMV7219 is available in the SC-70 and SOT-23 packages, which are ideal for systems where small size and low power are critical.

Applications

- Portable and Battery-powered Systems
- Scanners
- Set Top Boxes
- High Speed Differential Line Receiver
- Window Comparators
- Zero-crossing Detectors
- High-speed Sampling Circuits

Pin Configuration and Functions

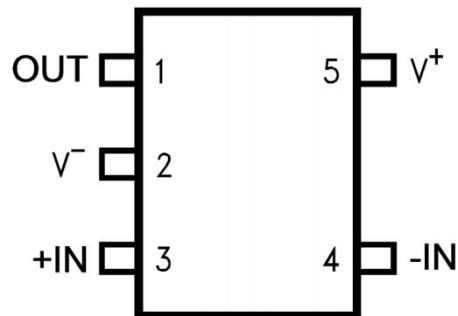

SOT-23-5/SC70-5

Pin		I/O	Description
Number	Name		
1	OUT	O	Output
2	V-	I	Negative Supply
3	+IN	I	Non-inverting input
4	-IN	I	Inverting input
5	V+	I	Positive Supply

Functional Block Diagram

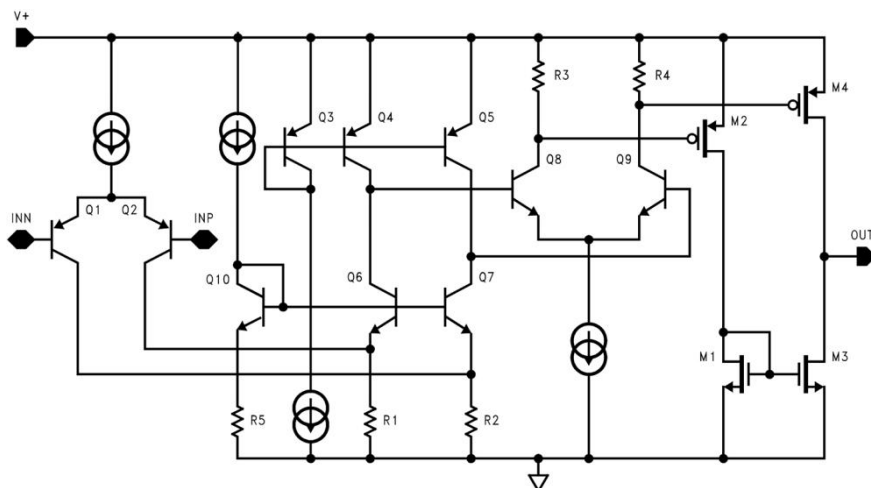

Absolute Maximum Ratings

over operating free-air temperature range (unless otherwise noted)⁽¹⁾

Parameter		Min	Max	Unit
Differential input voltage			± Supply Voltage	V
Output short circuit duration			See ⁽²⁾	V
Supply voltage (V ⁺ - V ⁻)			5.5	V
Soldering information (10 sec)			245	°C
Voltage at input/output pins		(V ⁻) -0.4	(V ⁺) +0.4	V
Current at input pin ⁽⁴⁾		-10	+10	mA
Maximum junction temperature			150	°C
Storage temperature		-65	150	°C
Electrostatic discharge	Human-body model (HBM)		+2000	V
	Charged-device model (CDM)		+150	V
Junction-to-ambient thermal resistance R _{θJA}	SOT23		209	°C/W
	SC70		296	°C/W
Junction-to-case (top) thermal resistance R _{θJC}	SOT23		170	°C/W
	SC70		132	°C/W

(1) Absolute Maximum Ratings indicate limits beyond which damage to the device may occur. Operating Ratings indicate conditions for which the device is intended to be functional, but specific performance is not ensured. For ensured specifications and the test conditions, see the Electrical characteristics.

(2) Applies to both single-supply and split-supply operation. Continuous short circuit operation at elevated ambient temperature can result in exceeding the maximum allowed junction temperature of 150°C. Output currents in excess of ±30mA over long term may adversely affect reliability.

(3) Limiting input pin current is only necessary for input voltages that exceed absolute maximum input voltage ratings.

Recommended Operating Conditions

over operating free-air temperature range (unless otherwise noted)

Parameter	Min	Max	Unit
Supply voltages (V ⁺ - V ⁻)	2.7	5	V
Ambient Temperature	-40	+85	°C
Junction Temperature		125	°C
PCB Temperature		105	°C

(1) The maximum power dissipation is a function of T_{J(MAX)}, R_{θJA}, and T_A. The maximum allowable power dissipation at any ambient temperature is P_D = (T_{J(MAX)} - T_A)/R_{θJA}. All numbers apply for packages soldered directly into a PC board.

Electrical Characteristics 2.7 V

Unless otherwise specified, all limits ensured for $T_J = 25^\circ\text{C}$, $V_{CM} = V^+ / 2$, $V^+ = 2.7\text{V}$, $V^- = 0\text{V}$, $C_L = 10\text{pF}$ and $R_L > 1\text{M}\Omega$ to V^-

Symbol	Parameter	Test Conditions	Min	Typ	Max	Unit		
V_{OS}	Input offset voltage			1	6	mV		
		$-40^\circ\text{C} \leq T_J \leq +85^\circ\text{C}$			8			
I_B	Input bias current			450	950	nA		
		$-40^\circ\text{C} \leq T_J \leq +85^\circ\text{C}$			2000			
I_{OS}	Input offset current			50	200	nA		
		$-40^\circ\text{C} \leq T_J \leq +85^\circ\text{C}$			400			
CMRR	Commonmode rejection ratio	$0\text{V} < V_{CM} < 1.50\text{V}$		62	85	dB		
			$-40^\circ\text{C} \leq T_J \leq +85^\circ\text{C}$		55			
PSRR	Power supply rejection ratio	$V^+ = 2.7\text{V}$ to 5V		65	85	dB		
			$-40^\circ\text{C} \leq T_J \leq +85^\circ\text{C}$		55			
V_{CM}	Input common-voltage range	CMRR > 50 dB		$V_{CC} - 1.2$	$V_{CC} - 1$	V		
			$-40^\circ\text{C} \leq T_J \leq +85^\circ\text{C}$		$V_{CC} - 1.3$			
					-0.2		-0.1	
			$-40^\circ\text{C} \leq T_J \leq +85^\circ\text{C}$				0	
V_{OH}	Output swing high	$I_L = 4\text{mA}$, $V_{ID} = 500\text{mV}$		$V_{CC} - 0.3$	$V_{CC} - 0.22$	V		
			$-40^\circ\text{C} \leq T_J \leq +85^\circ\text{C}$		$V_{CC} - 0.4$			
					$V_{CC} - 0.05$		$V_{CC} - 0.02$	
V_{OL}	Output swing low	$I_L = -0.4\text{mA}$, $V_{ID} = 500\text{mV}$		$V_{CC} - 0.15$		mV		
			$-40^\circ\text{C} \leq T_J \leq +85^\circ\text{C}$				130	200
							15	50
I_{SC}	Output short circuit current	Sourcing, $V_O = 0\text{V}$ ⁽¹⁾ Sinking, $V_O = 2.7\text{V}$ ⁽¹⁾			20	mA		
			$-40^\circ\text{C} \leq T_J \leq +85^\circ\text{C}$				20	
I_S	Supply current	No Load			0.9	1.6	mA	
			$-40^\circ\text{C} \leq T_J \leq +85^\circ\text{C}$					2.2
V_{HYST}	Input hysteresis voltage	See ⁽²⁾		7		mV		
V_{TRIP+}	Input referred positive trip point	(see Figure 19)		3	8	mV		
V_{TRIP-}	Input referred negative trip point	(see Figure 19)	-8	-4		mV		
t_{PD}	Propagation delay	Overdrive = 5 mV, $V_{CM} = 0\text{V}$ ⁽³⁾			12	ns		
			$-40^\circ\text{C} \leq T_J \leq +85^\circ\text{C}$				11	
					10		20	
t_{SKEW}	Propagation delay skew	See ⁽⁴⁾		1		ns		
t_r	Output rise time	10% to 90%		2.5		ns		
t_f	Output fall time	90% to 10%		2		ns		

(1) Applies to both single-supply and split-supply operation. Continuous short circuit operation at elevated ambient temperature can result in exceeding the maximum allowed junction temperature of 150°C . Output currents in excess of $\pm 30\text{mA}$ over long term may adversely affect reliability.

(2) The LMV7219 comparator has internal hysteresis. The trip points are the input voltage needed to change the output state in each direction. The offset voltage is defined as the average of V_{TRIP+} and V_{TRIP-} , while the hysteresis voltage is the difference of these two.

(3) Propagation delay measurements made with 100 mV steps. Overdrive is measured relative to V_{TRIP} .

(4) Propagation Delay Skew is defined as absolute value of the difference between t_{PDLH} and t_{PDHL} .

Electrical Characteristics 5 V

Unless otherwise specified, all limits ensured for $T_J = 25^\circ\text{C}$, $V_{CM} = V^+/2$, $V^+ = 5\text{ V}$, $V^- = 0\text{ V}$, $C_L = 10\text{ pF}$ and $R_L > 1\text{ M}\Omega$ to V^- .

Symbol	Parameter	Test Conditions	Min	Typ	Max	Unit		
V_{OS}	Input offset voltage			1	6	mV		
		$-40^\circ\text{C} \leq T_J \leq +85^\circ\text{C}$			8			
I_B	Input bias current			500	950	nA		
		$-40^\circ\text{C} \leq T_J \leq +85^\circ\text{C}$			2000			
I_{OS}	Input offset current			50	200	nA		
		$-40^\circ\text{C} \leq T_J \leq +85^\circ\text{C}$			400			
CMRR	Commonmode rejection ratio	$0\text{V} < V_{CM} < 3.8\text{V}$		65	85	dB		
			$-40^\circ\text{C} \leq T_J \leq +85^\circ\text{C}$		55			
PSRR	Power supply rejection ratio	$V^+ = 2.7\text{ V to } 5\text{ V}$		65	85	dB		
			$-40^\circ\text{C} \leq T_J \leq +85^\circ\text{C}$		55			
V_{CM}	Input common-voltage range	CMRR > 50 dB		$V_{CC}-1.2$	$V_{CC}-1$	V		
			$-40^\circ\text{C} \leq T_J \leq +85^\circ\text{C}$		$V_{CC}-1.3$			
					-0.2		-0.1	
			$-40^\circ\text{C} \leq T_J \leq +85^\circ\text{C}$				0	
V_{OH}	Output swing high	$I_L = 4\text{ mA}$, $V_{ID} = 500\text{ mV}$		$V_{CC}-0.2$	$V_{CC}-0.13$	V		
			$-40^\circ\text{C} \leq T_J \leq +85^\circ\text{C}$		$V_{CC}-0.3$			
			$I_L = 0.4\text{ mA}$, $V_{ID} = 500\text{ mV}$		$V_{CC}-0.05$		$V_{CC}-0.02$	
			$-40^\circ\text{C} \leq T_J \leq +85^\circ\text{C}$		$V_{CC}-0.15$			
V_{OL}	Output swing low	$I_L = -4\text{ mA}$, $V_{ID} = -500\text{ mV}$			80	mV		
			$-40^\circ\text{C} \leq T_J \leq +85^\circ\text{C}$				280	
			$I_L = -0.4\text{ mA}$, $V_{ID} = -500\text{ mV}$				15	50
			$-40^\circ\text{C} \leq T_J \leq +85^\circ\text{C}$				150	
I_{SC}	Output short circuit current	Sourcing, $V_O = 0\text{V}^{(1)}$		30	68	mA		
			$-40^\circ\text{C} \leq T_J \leq +85^\circ\text{C}$		20			
			Sinking, $V_O = 5\text{V}^{(1)}$		30		65	
			$-40^\circ\text{C} \leq T_J \leq +85^\circ\text{C}$		20			
I_S	Supply current	No Load		1.1	1.8	mA		
			$-40^\circ\text{C} \leq T_J \leq +85^\circ\text{C}$				2.4	
V_{HYST}	Input hysteresis voltage	See ⁽²⁾		7.5		mV		
V_{TRIP+}	Input referred positive trip point	(see Figure 19)		3.5	8	mV		
V_{TRIP-}	Input referred negative trip point	(see Figure 19)	-8	-4		mV		
t_{PD}	Propagation delay	Overdrive = 5 mV, $V_{CM} = 0\text{ V}^{(3)}$		9		ns		
		Overdrive = 15 mV, $V_{CM} = 0\text{ V}^{(3)}$		8	20			
		Overdrive = 50 mV, $V_{CM} = 0\text{ V}^{(3)}$		7	19			
t_{SKEW}	Propagation delay skew	See ⁽⁴⁾		0.4		ns		
t_r	Output rise time	10% to 90%		1.3		ns		
t_f	Output fall time	90% to 10%		1.25		ns		

(1) Applies to both single-supply and split-supply operation. Continuous short circuit operation at elevated ambient temperature can result in exceeding the maximum allowed junction temperature of 150°C . Output currents in excess of $\pm 30\text{ mA}$ over long term may adversely affect reliability.

(2) The LMV7219 comparator has internal hysteresis. The trip points are the input voltage needed to change the output state in each direction. The offset voltage is defined as the average of V_{trip+} and V_{trip-} , while the hysteresis voltage is the difference of these two.

(3) Propagation delay measurements made with 100 mV steps. Overdrive is measured relative to V_{TRIP} .

(4) Propagation Delay Skew is defined as absolute value of the difference between t_{PDHL} and t_{PDLH} .

Typical Performance Characteristics

Unless otherwise specified, $V_S = 5\text{ V}$, $C_L = 10\text{ pF}$, $T_A = 25^\circ\text{C}$

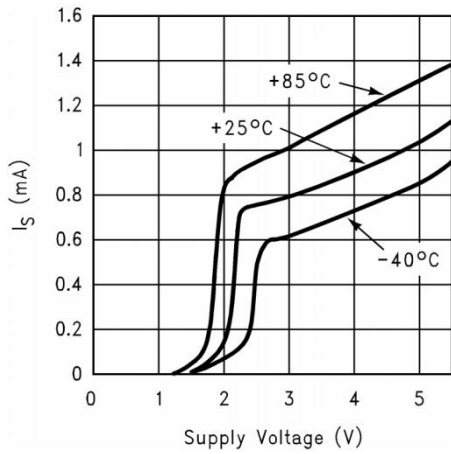

Figure 1. Supply Current vs. Supply Voltage

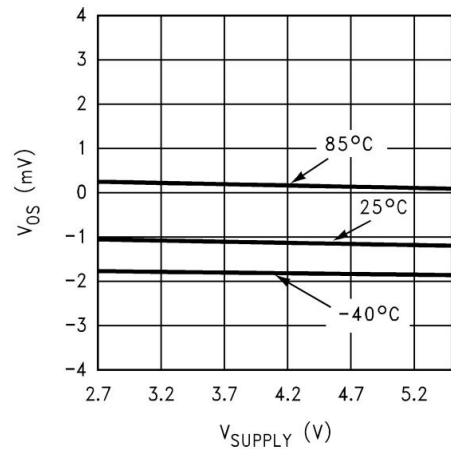

Figure 2. VOS vs. Supply Voltage

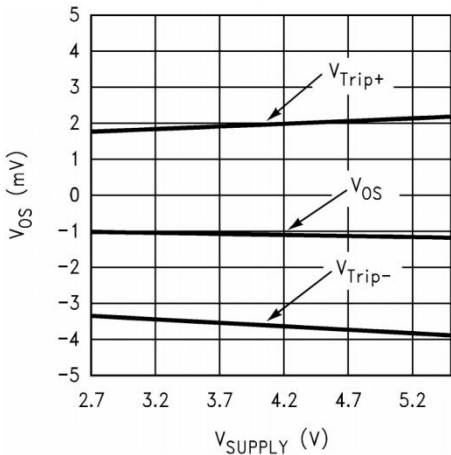
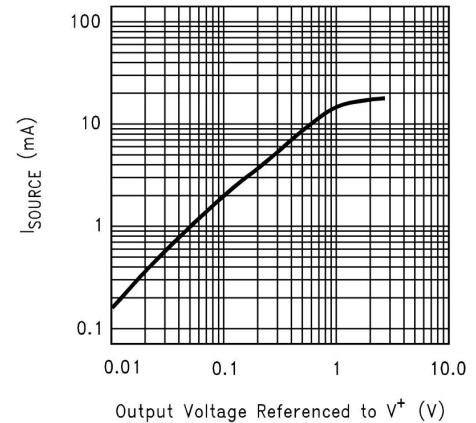
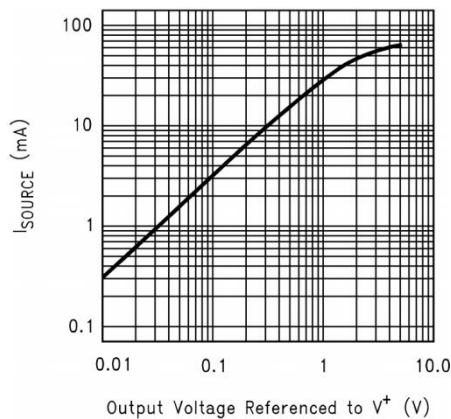

Figure 3. Input Offset and Trip Voltage vs. Supply Voltage



$V_S = 2.7\text{ V}$

Figure 4. Sourcing Current vs. Output Voltage



$V_S = 5\text{ V}$

Figure 5. Sourcing Current vs. Output Voltage

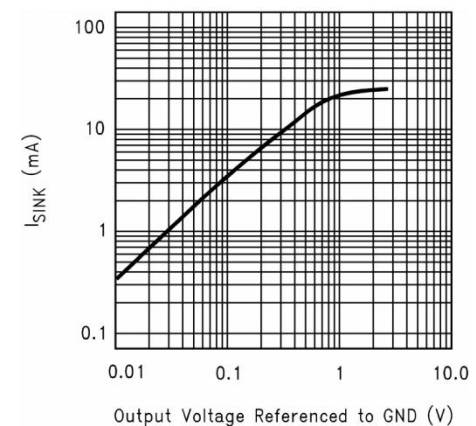

$V_S = 2.7\text{ V}$

Figure 6. Sinking Current vs. Output Voltage

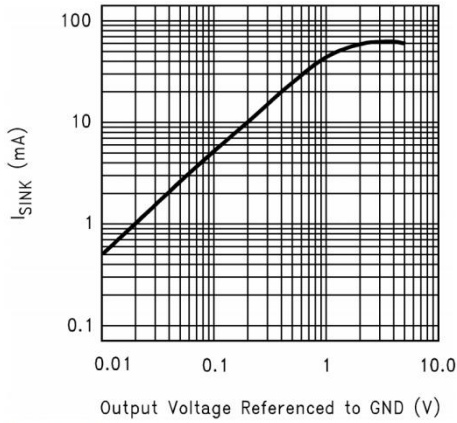

$V_S = 5\text{ V}$

Figure 7. Sinking Current vs. Output Voltage

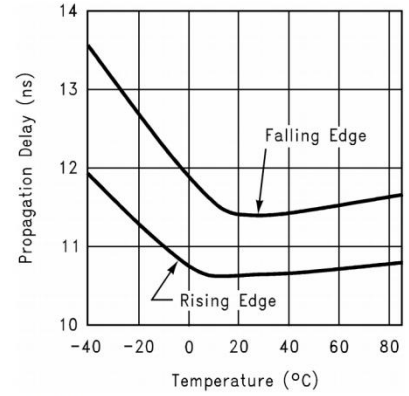

$V_S = 2.7\text{ V}$

$V_{OD} = 15\text{ mV}$

Figure 8. Propagation Delay vs. Temperature

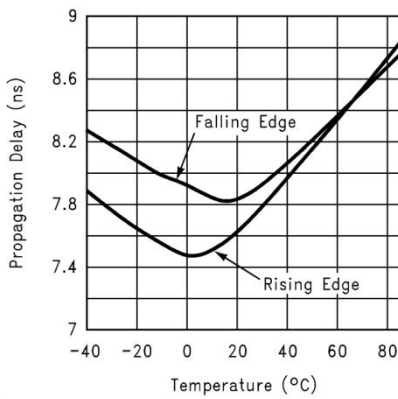

$V_S = 5\text{ V}$

$V_{OD} = 15\text{ mV}$

Figure 9. Propagation Delay vs. Temperature

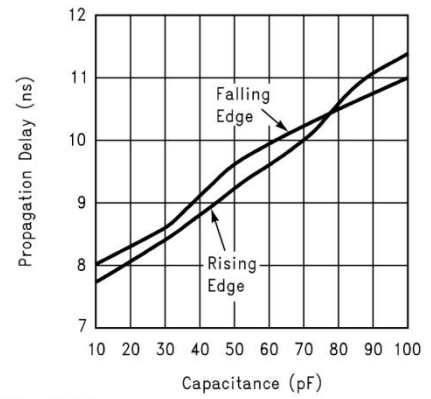

$V_S = 5\text{ V}$

$V_{OD} = 15\text{ mV}$

Figure 10. Propagation Delay vs. Capacitive Load

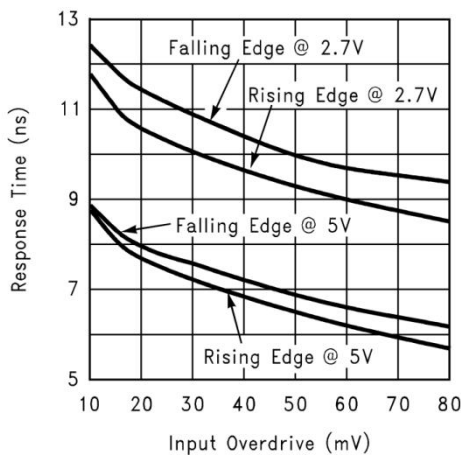
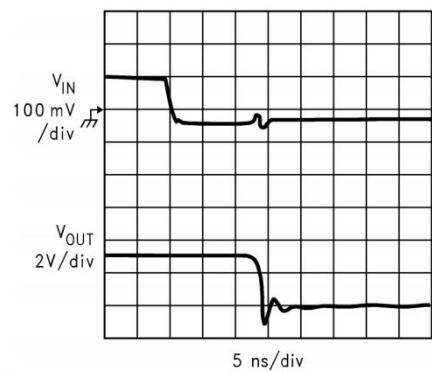

Figure 11. Propagation Delay vs. Input Overdrive



$V_S = 2.7\text{ V}$

$C_L = 10\text{ pF}$

$V_{OD} = 15\text{ mV}$

Figure 12. Propagation Delay (t_{PD-})

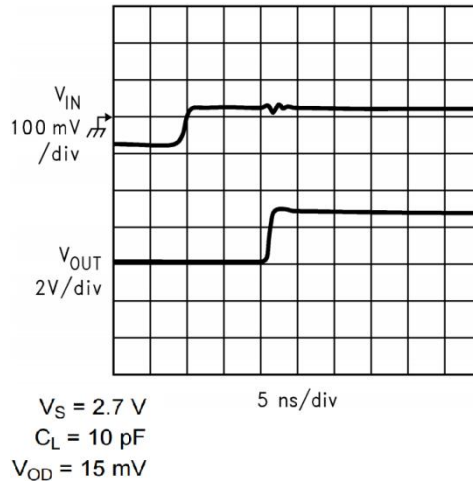
Figure 13. Propagation Delay (t_{PD+})

Detailed Description

Overview

LMV7219 is a single supply comparator with internal hysteresis, 7 ns of propagation delay and only 1.1 mA of supply current.

The LMV7219 has a typical input common mode voltage range of $-0.2 V$ below the ground to $1 V$ below V_{CC} . The differential input stage is a pair of PNP transistors, therefore, the input bias current flows out of the device. If either of the input signals falls below the negative common mode limit, the parasitic PN junction formed by the substrate and the base of the PNP will turn on, resulting in an increase of input bias current.

Feature Description

If one of the inputs goes above the positive common mode limit, the output will still maintain the correct logic level as long as the other input stays within the common mode range. However, the propagation delay will increase. When both inputs are outside the common mode voltage range, current saturation occurs in the input stage, and the output becomes unpredictable.

Device Functional Modes

The propagation delay does not increase significantly with large differential input voltages. However, large differential voltages greater than the supply voltage should be avoided to prevent damages to the input stage.

The LMV7219 has a push-pull output. When the output switches, there is a direct path between V_{CC} and ground, causing high output sinking or sourcing current during the transition. After the transition, the output current decreases and the supply current settles back to about 1.1 mA at 5 V, thus conserving power consumption.

Most high-speed comparators oscillate when the voltage of one of the inputs is close to or equal to the voltage on the other input due to noise or undesirable feedback. The LMV7219 has 7 mV of internal hysteresis to counter parasitic effects and noise. The hysteresis does not change significantly with the supply voltages and the common mode input voltages as reflected in the specification table.

Application Information

The following section explains in detail how to manipulate the hysteresis voltage of the LMV7219. Detailed expressions are provided along with practical considerations for designing hysteresis.

Typical Application

Figure 14 shows the typical method of adding external hysteresis to a comparator. The positive feedback is responsible for shifting the comparator trip point depending on the state of the output.

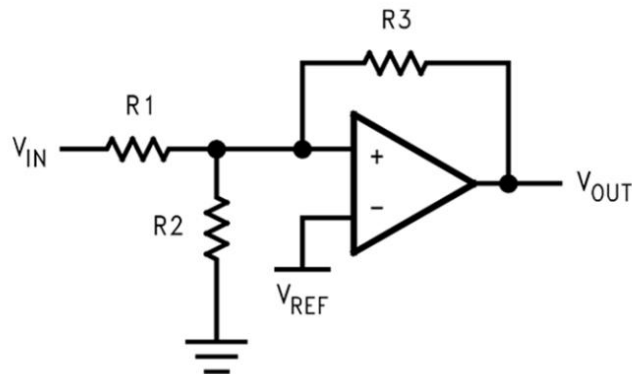

Figure 14. Additional Hysteresis

Design Requirements

The internal hysteresis creates two trip points, one for the rising input voltage and one for the falling input voltage, as shown in **Figure 19**. The difference between the trip points is the hysteresis. With internal hysteresis, when the comparator's input voltages are equal, the hysteresis effectively causes one comparator-input voltage to move quickly past the other, thus taking the input out of the region where oscillation occurs. Standard comparators require hysteresis to be added with external resistors. The fixed internal hysteresis eliminates these resistors.

Detailed Design Procedure

Additional Hysteresis

If additional hysteresis is desired, this can be done with the addition of three resistors using positive feedback, as shown in **Figure 14**. The positive feedback method slows the comparator response time. Calculate the resistor values as follows:

1. Select R3. The current through R3 should be greater than the input bias current to minimize errors. The current through R3 (I_F) at the trip point is $(V_{REF} - V_{OUT}) / R3$. Consider the two possible output states when solving for R3, and use the smaller of the two resulting resistor values. The two formulas are:

$$R3 = V_{REF} / I_F \quad (1)$$

When $V_{OUT} = 0$:

$$R3 = V_{CC} - V_{REF} / I_F \quad (2)$$

When $V_{OUT} = V_{CC}$:

2. Choose a hysteresis band required (V_{HB}).

3. Calculate R1, where $R1 = R3 \times (V_{HB} / V_{CC})$

4. Choose the trip point for V_{IN} rising. This is the threshold voltage (V_{THR}) at which the comparator switches from low to high as V_{IN} rises about the trip point.
5. Calculate R_2 as follows:

$$R_2 = \frac{1}{\left(\frac{V_{THR}}{V_{REF} \times R_1}\right) - \frac{1}{R_1} - \frac{1}{R_3}} \quad (3)$$

6. Verify the trip voltage and hysteresis as follows:

$$V_{IN} \text{ rising: } V_{THR} = V_{REF} \times R_1 \times \left(\frac{1}{R_1} + \frac{1}{R_2} + \frac{1}{R_3}\right)$$

$$V_{IN} \text{ falling: } V_{THF} = V_{THR} - \left(\frac{R_1 \times V_{CC}}{R_3}\right)$$

$$\text{Hysteresis} = V_{THR} - V_{THF} \quad (4)$$

This method is recommended for additional hysteresis of up to a few hundred millivolts. Beyond that, the impedance of R_3 is low enough to affect the bias string and adjustment of R_1 may be also required.

Zero-Crossing Detector

The inverting input is connected to ground and the non-inverting input is connected to 100mVp-p signal. As the signal at the non-inverting input crosses 0 V, the comparator's output Changes State.

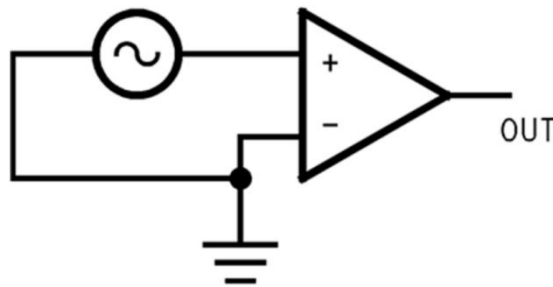

Figure 15. Zero-Crossing Detector

Threshold Detector

Instead of tying the inverting input to 0 V, the inverting input can be tied to a reference voltage. The non-inverting input is connected to the input. As the input passes the V_{REF} threshold, the comparator's output changes state.

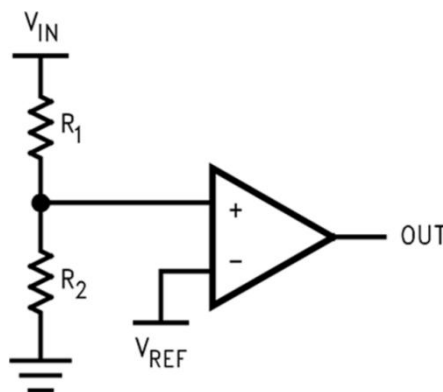

Figure 16. Threshold Detector

Crystal Oscillator

A simple crystal oscillator using the LMV7219 is shown in **Figure 17**. Resistors R1 and R2 set the bias point at the comparator's non-inverting input. Resistors R3, R4 and C1 sets the inverting input node at an appropriate DC average level based on the output. The crystal's path provides resonant positive feedback and stable oscillation occurs. The output duty cycle for this circuit is roughly 50%, but it is affected by resistor tolerances and to a lesser extent by the comparator offset.

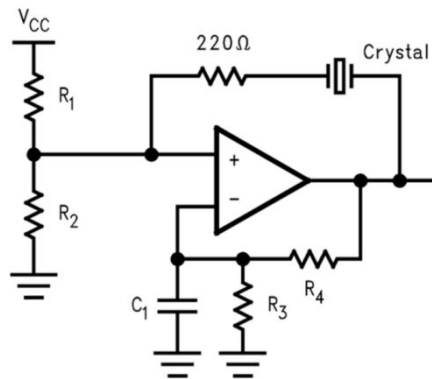

Figure 17. Crystal Oscillator

IR Receiver

The LMV7219 is an ideal candidate to be used as an infrared receiver. The infrared photo diode creates a current relative to the amount of infrared light present. The current creates a voltage across RD. When this voltage level cross the voltage applied by the voltage divider to the inverting input, the output transitions.

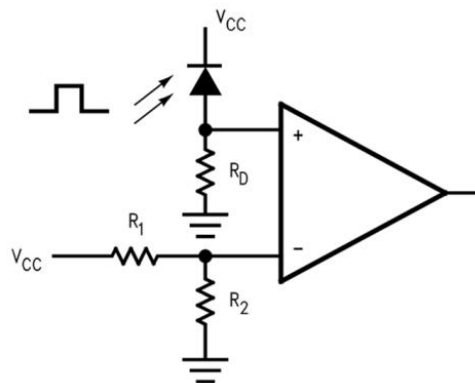

Figure 18. IR Receiver

Application Curve

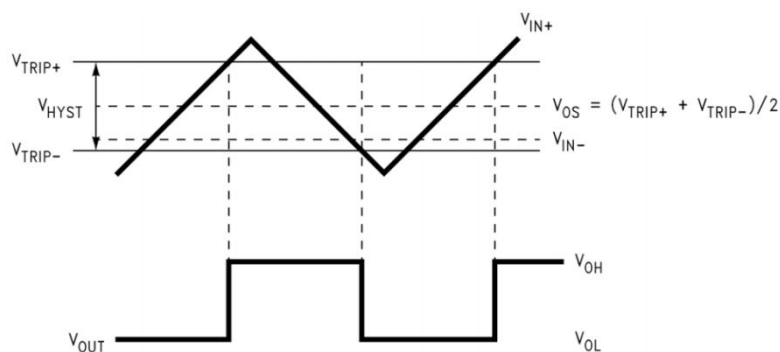
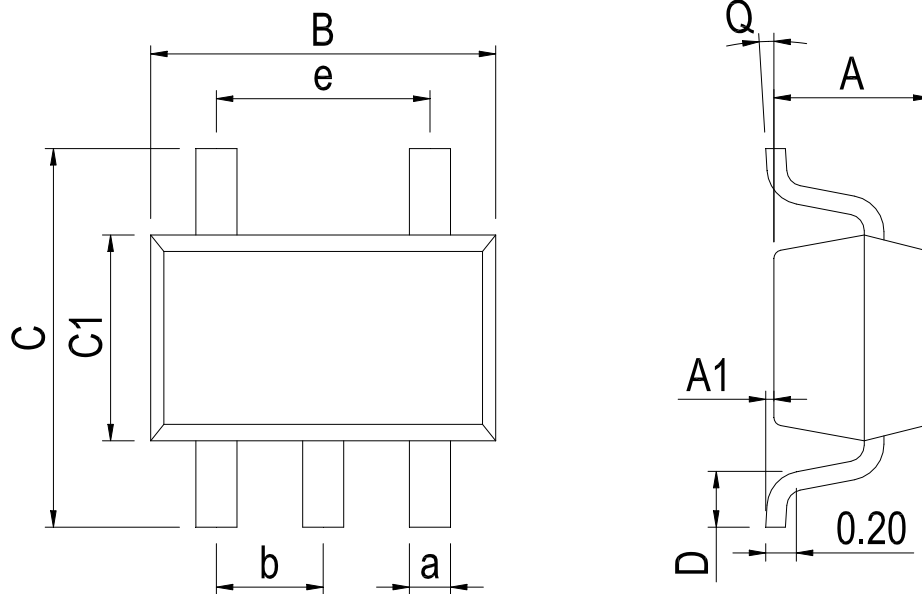

Figure 19. Input and Output Waveforms, Non-Inverting Input Varied

Physical Dimensions

SOT-23-5



Dimensions In Millimeters(SOT-23-5)

Symbol:	A	A1	B	C	C1	D	Q	a	b	e
Min:	1.05	0.00	2.82	2.65	1.50	0.30	0°	0.30	0.95 BSC	1.90 BSC
Max:	1.15	0.15	3.02	2.95	1.70	0.60	8°	0.40		

SC70-5

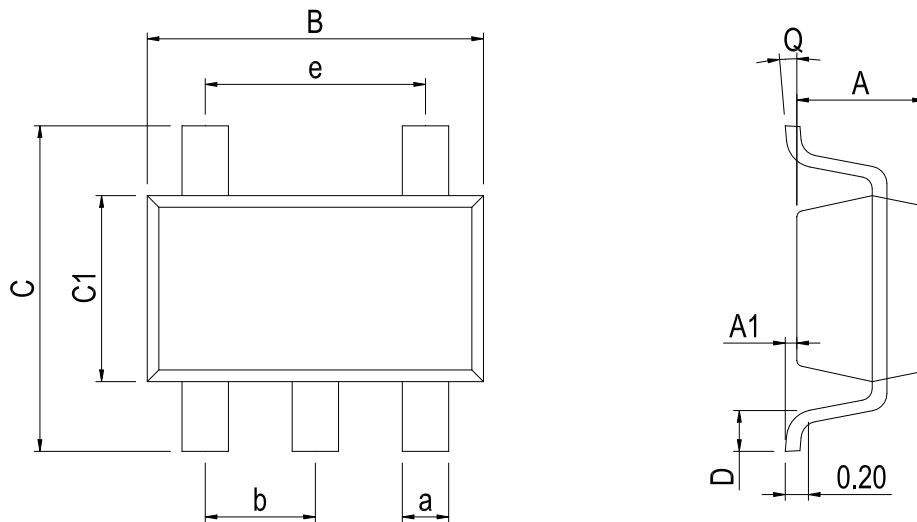

Dimensions In Millimeters(SC70-5)

Symbol:	A	A1	B	C	C1	D	Q	a	b	e
Min:	0.90	0.00	2.00	2.15	1.15	0.26	0°	0.15	0.65	1.30 BSC
Max:	1.00	0.15	2.20	2.45	1.35	0.46	8°	0.35	BSC	

Revision History

DATE	REVISION	PAGE
2019-4-19	New	1-14
2023-10-31	Document Reformatting, Update SC70-5 Physical Dimensions	1-14, 12

IMPORTANT STATEMENT:

Huaguan Semiconductor reserves the right to change its products and services without notice. Before ordering, the customer shall obtain the latest relevant information and verify whether the information is up to date and complete. Huaguan Semiconductor does not assume any responsibility or obligation for the altered documents.

Customers are responsible for complying with safety standards and taking safety measures when using Huaguan Semiconductor products for system design and machine manufacturing. You will bear all the following responsibilities: Select the appropriate Huaguan Semiconductor products for your application; Design, validate and test your application; Ensure that your application meets the appropriate standards and any other safety, security or other requirements. To avoid the occurrence of potential risks that may lead to personal injury or property loss.

Huaguan Semiconductor products have not been approved for applications in life support, military, aerospace and other fields, and Huaguan Semiconductor will not bear the consequences caused by the application of products in these fields. All problems, responsibilities and losses arising from the user's use beyond the applicable area of the product shall be borne by the user and have nothing to do with Huaguan Semiconductor, and the user shall not claim any compensation liability against Huaguan Semiconductor by the terms of this Agreement.

The technical and reliability data (including data sheets), design resources (including reference designs), application or other design suggestions, network tools, safety information and other resources provided for the performance of semiconductor products produced by Huaguan Semiconductor are not guaranteed to be free from defects and no warranty, express or implied, is made. The use of testing and other quality control technologies is limited to the quality assurance scope of Huaguan Semiconductor. Not all parameters of each device need to be tested.

The documentation of Huaguan Semiconductor authorizes you to use these resources only for developing the application of the product described in this document. You have no right to use any other Huaguan Semiconductor intellectual property rights or any third party intellectual property rights. It is strictly forbidden to make other copies or displays of these resources. You should fully compensate Huaguan Semiconductor and its agents for any claims, damages, costs, losses and debts caused by the use of these resources. Huaguan Semiconductor accepts no liability for any loss or damage caused by infringement.

X-ON Electronics

Largest Supplier of Electrical and Electronic Components

Click to view similar products for [Analog Comparators](#) category:

Click to view products by [HGSEMI](#) manufacturer:

Other Similar products are found below :

[SC2903VDR2G](#) [LM2901SNG](#) [LM339SNG](#) [55122](#) [5962-8757203IA](#) [NTE911](#) [LM339EDR2G](#) [NTE922](#) [UPC177GR-9LG-E2-A](#)
[HT393VRMZ](#) [LM2903YD](#) [NCV2200SN1T1G](#) [LM2903A-SR](#) [LM339A-SR](#) [HT339ARQZ](#) [LM2901XP](#) [LM2903DR-JSM](#) [MS8923](#)
[LM239AM/TR](#) [LM393LVQDGKRQ1](#) [LM393LVQPWRQ1](#) [LM2903BWDSGRQ1](#) [TLV3801DSGT](#) [LM331BXF](#) [AD790JRZ-REEL](#)
[LM339A-TR](#) [LT6700HVHS6-1#TRPBF](#) [GS2903-SR](#) [LMV7219M5/TR](#) [LMV7239M5/TR](#) [LM293ADR-HXY](#) [LM293DR-HXY](#) [LM339N-](#)
[HXY](#) [LM393P-HXY](#) [IL339DT](#) [LM2901XQ](#) [RS331XF-Q1](#) [MIC842NYMT-TR](#) [LM393FVM-TR](#) [LM393P](#) [TLV3602QDGKRQ1](#)
[TLV7032QDGKRQ1](#) [TLV3601QDBVRQ1](#) [LM2901BQPWRQ1](#) [TLV3603DCKR](#) [TLV3603DCKT](#) [AiP74HC85TA16.TB](#)
[LMV331IDBVR\(MS\)](#) [LMV331W5-7\(MS\)](#) [MCP6561UT-E\(MS\)](#)