

Low-Power μ P Supervisor Circuits

DESCRIPTION

The MAX706/MAX706T/MAX706S/MAX706R CMOS supervisor circuits monitor power-supply and battery voltage level, and μ P/ μ C operation. Compared to pin-compatible devices offered by Maxim Integrated Products, these devices feature 60 percent lower maximum supply current.

The family offers several functional options. Each device generates a reset signal during power-up, power-down and during brownout conditions.

A reset is generated when the supply drops below 4.4V (MAX706), 3.08V (MAX706T), 2.93V (MAX706S), 2.63V (MAX706R). In addition, the MAX706/T/S/R feature a 2.4 second watchdog timer. A versatile power-fail circuit has a 1.25V threshold, useful in checking battery levels and non-5V supplies. All devices have a manual reset (\overline{MR}) input. The watchdog timer output will trigger a reset if connected to \overline{MR} .

All devices are available in DIP8, SOP8 and MSOP8 packages.

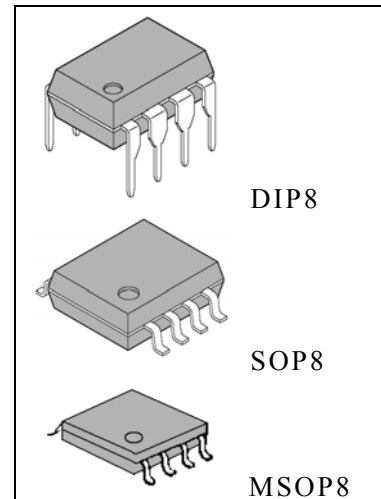

ORDERING INFORMATION

DEVICE	Package Type	MARKING	Packing	Packing Qty
MAX607N	DIP8L	MAX607	TUBE	2000pcs/box
MAX607TN	DIP8L	MAX607T	TUBE	2000pcs/box
MAX607SN	DIP8L	MAX607S	TUBE	2000pcs/box
MAX607RN	DIP8L	MAX607R	TUBE	2000pcs/box
MAX607M/TR	SOP8L	X607	REEL	2500pcs/reel
MAX607TM/TR	SOP8L	X607T	REEL	2500pcs/reel
MAX607SM/TR	SOP8L	X607S	REEL	2500pcs/reel
MAX607RM/TR	SOP8L	X607R	REEL	2500pcs/reel
MAX607MM/TR	MSOP8L	X607	REEL	3000pcs/reel
MAX607TMM/TR	MSOP8L	X607T	REEL	3000pcs/reel
MAX607SMM/TR	MSOP8L	X607S	REEL	3000pcs/reel
MAX607RMM/TR	MSOP8L	X607R	REEL	3000pcs/reel

FEATURES

- Improved replacements for the Maximum MAX706/T/S/R
 - 140 μ A maximum supply current
 - 60% improvement
- Precision power supply monitor
 - 4.4V threshold (MAX706)
 - 3.08V threshold (MAX706T)
 - 2.93V threshold (MAX706S)
 - 2.63V threshold (MAX706R)
- Debounced manual reset input
- Voltage monitor
 - 1.25V threshold
 - Battery monitor/Auxiliary supply monitor
- Watchdog timer (MAX706/MAX706T/MAX706S/MAX706R)
- 300ms reset pulse width
- MicroSO package

BLOCK DIAGRAM

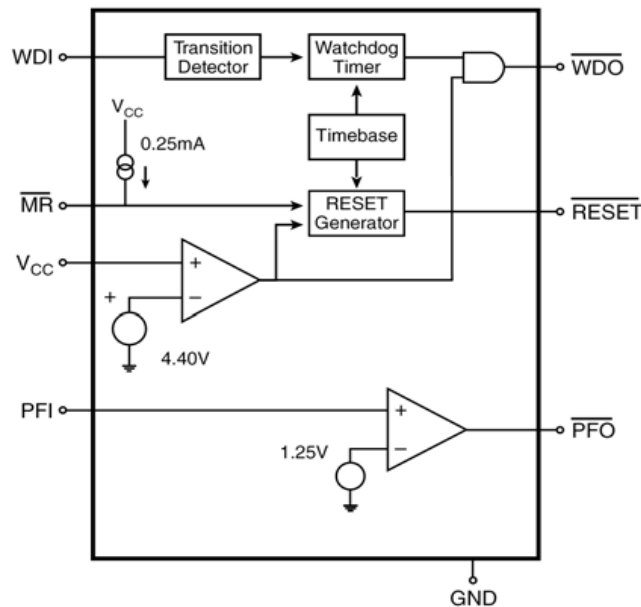

APPLICATIONS

- Computers and embedded controllers
- Intelligent instruments
- PDAs and handheld equipment
- Battery-operated systems
- Wireless communication systems

PIN CONFIGURATION

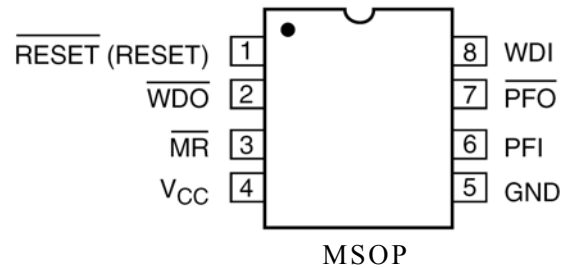
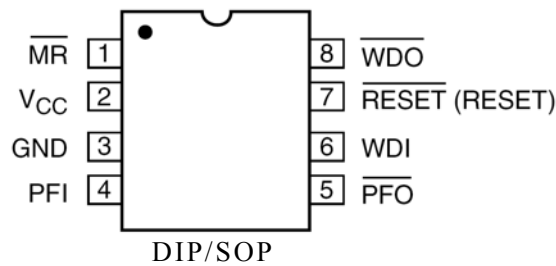

PIN DESCRIPTION

Pin No.		Name	Pin Function
MAX706/MAX706T/MAX706S/MAX706R			
DIP/SOP	MSOP		
1	3	\overline{MR}	Manual RESET input. The active LOW input triggers a reset pulse. A 250 μ A pull-up current allows the pin to be driven by TTL / CMOS logic or shorted to ground with a switch.
2	4	V _{CC}	+5V power supply input.
3	5	GND	Ground reference for all signals.
4	6	PFI	Power-fail voltage monitor input. With PFI less than 1.25V, \overline{PFO} goes low. Connect PFI to ground or V _{CC} when not used.
5	7	\overline{PFO}	Power-fail output. The output is active LOW and sinks current when PFI is less than 1.25V.
6	8	WDI	Watchdog input. WDI controls the internal watchdog timer. A HIGH or LOW signal for 2.4sec at WDI allows the internal timer to run-out, setting \overline{WDO} LOW. The watchdog function is disabled by floating WDI or by connecting WDI to a high-impedance

6	8	WDI	three-state buffer. The internal watchdog timer clears when: RESET is asserted; WDI is three-stated; or WDI sees a rising or falling edge.
7	1	\overline{RESET}	Active-LOW reset output. Pulses LOW for 300ms when triggered, and stays low whenever Vcc is below the reset threshold (MAX706: 4.4V, MAX706T: 3.08V, MAX706S: 1.93V, MAX706R: 2.63V). \overline{RESET} remains LOW for 300ms after Vcc rises above the RESET threshold or \overline{MR} goes from LOW to HIGH. A watchdog timeout will not trigger \overline{RESET} unless \overline{WDO} is connected to \overline{MR} .
8	2	\overline{WDO}	Watchdog output. \overline{WDO} pulls LOW when the 2.4 sec internal watchdog timer times-out and does not go HIGH until the watchdog is cleared. In addition, when Vcc is below the reset threshold, \overline{WDO} remains low. Unlike \overline{RESET} , \overline{WDO} does not have a minimum pulse width and as soon as Vcc exceeds the reset threshold, \overline{WDO} goes HIGH with no delay.

ABSOLUTE MAXIMUM RATING (Ta=25°C)

Characteristics	Value	Unit
Supply voltage	-0.3 ~ +6.0	V
All other inputs *1	-0.3 ~ Vcc+0.3	V
Input current at Vcc and GND	20	mA
Output current :All outputs	20	mA
Rate of Rise at Vcc	100	V/μs
Plastic DIP power dissipation (Derate 9mW/°C above 70°C)	700	mW
SOP power dissipation (Derate 5.9mW/°C above 70°C)	470	mW
MSOP power dissipation (Derate 4.1mW/°C above 70°C)	330	mW
Operating temperature range	0 ~ 70	°C
Storage temperature range	-65 ~ +150	°C
Lead temperature (soldering, 10 sec.)	300	°C

*1. The input voltage limits on PFI and \overline{MR} can be exceeded if the input current is less than 10mA.

ELECTRICAL CHARACTERISTICS

 (Unless otherwise noted, $V_{CC} = 4.5V$ to $5.5V$ for the MAX706/MAX706T/MAX706S/MAX706R)

Characteristics	Symbol	Conditions	Min.	Typ.	Max	Unit
Operating voltage range	V_{CC}	MAX706/T/S/R	1.2		5.5	V
Supply current	I_{CC}	MAX706/T/S/R		75	140	μA
\overline{RESET} threshold	V_{RT}	MAX706	4.25	4.4	4.5	V
		MAX706T	2.98	3.08	3.15	
		MAX706S	2.83	2.93	3	
		MAX706R	2.54	2.63	2.69	
\overline{RESET} threshold hysteresis				40		mV
\overline{RESET} pulse width	t_{RS}		140	300	420	ms
\overline{MR} pulse width	t_{MR}		0.15			μs
\overline{MR} to \overline{RESET} out delay	t_{MD}				0.25	μs
\overline{MR} input threshold	V_{IH}		2.0			V
	V_{IL}				0.8	
\overline{MR} pull-up current		$\overline{MR} = 0V$	100	250	600	μA
\overline{RESET} output voltage		$I_{SOURCE} = 800\mu A$	$V_{CC} - 1.5$			V
		$I_{SINK} = 3.2mA$			0.4	
		MAX706/T/S/R, $V_{CC} = 1.2V$, $I_{SINK} = 100\mu A$			0.3	
Watchdog timeout period	t_{WD}	MAX706/T/S/R	2.00	2.4	3.00	s
WDI pulse width	t_{WP}	$V_{IL} = 0.4V, V_{IH} = 0.8V_{CC}$	50			ns
WDI input threshold	V_{IH}	MAX706/T/S/R, $V_{CC} = 5V$	3.5			V
	V_{IL}				0.8	
WDI input current		MAX706/T/S/R, $WDI = V_{CC}$		50	150	μA
		MAX706/T/S/R, $WDI = 0V$	-150	-50		
\overline{WDO} output voltage		MAX706/T/S/R, $I_{SOURCE} = 800\mu A$	$V_{CC} - 1.5$			V
		MAX706/T/S/R, $I_{SINK} = 1.2mA$			0.4	
PFI input threshold		$V_{CC} = 5V$	1.20	1.25	1.30	V
PFI input current			-25	0.01	25	nA
\overline{PFO} output voltage		$I_{SOURCE} = 800\mu A$	$V_{CC} - 1.5$			V
		$I_{SINK} = 3.2mA$			0.4	

FEATURE SUMMARY

	MAX706	MAX706T	MAX706S	MAX706R
Power-fail detector	●	●	●	●
Brownout detection	●	●	●	●
Manual RESET input	●	●	●	●
Power-up/down RESET	●	●	●	●
Watchdog timer	●	●	●	●
Active-HIGH RESET output				
Active-LOW RESET output	●	●	●	●
RESET threshold	4.4V	3.08V	2.93V	2.63V

DETAIL DESCRIPTIONS

\overline{RESET} Operation

The \overline{RESET} signals are designed to start a $\mu\text{P}/\mu\text{C}$ in a known state or return the system to a known state.

\overline{RESET} is guaranteed to be LOW with V_{CC} above 1.2V. During a power-up sequence, \overline{RESET} remains low until the supply rises above the threshold level, either 4.4V, 3.08V, 2.93V or 2.63V. \overline{RESET} goes high approximately 300ms after crossing the threshold.

During power-down, \overline{RESET} goes LOW as V_{CC} falls below the threshold level and is guaranteed to be under 0.4V with V_{CC} above 1.2V.

In a brownout situation where V_{CC} falls below the threshold level, \overline{RESET} pulses low. If a brownout occurs during an already initiated reset, the pulse will continue for a minimum of 140ms.

Auxiliary Comparator

All devices have an auxiliary comparator with 1.25V trip point and uncommitted output (\overline{PFO}) and noninverting input (PFI). This comparator can be used as a supply voltage monitor with an external resistor voltage divider. The attenuated voltage at PFI should be set just below the 1.25 threshold. As the supply level falls, PFI is reduced causing the \overline{PFO} output to transit LOW. Normally \overline{PFO} interrupts the processor so the system can be shut down in a controlled manner.

Manual Reset (\overline{MR})

The active-LOW manual reset input is pulled high by a 250 μA pull-up current and can be driven low by CMOS/TTL logic or a mechanical switch to ground. An external debounce circuit is unnecessary since the 140ms minimum reset time will debounce mechanical pushbutton switches.

By connecting the watchdog output (\overline{WDO}) and \overline{MR} , a watchdog timeout forces \overline{RESET} to be generated.

Watchdog Timer

The watchdog timer available on the MAX706/MAX706T/MAX706S/MAX706R monitors $\mu\text{P}/\mu\text{C}$ activity. If activity is not detected within 2.4 seconds, the internal timer puts the

watchdog output, \overline{WDO} , into a LOW state. \overline{WDO} will remain LOW until activity is detected at WDI.

The watchdog function is disabled, meaning it is cleared and not counting, if WDI is floated or connected to a three-stated circuit. The watchdog timer is also disabled if RESET is asserted. When RESET becomes inactive and the WDI input sees a high or low transition as short as 50ns, the watchdog timer will begin a 2.4 second countdown.

Additional transitions at WDI will reset the watchdog timer and initiate a new countdown sequence.

\overline{WDO} will also become LOW and remain so, whenever the supply voltage, V_{CC} , falls below the device threshold level. \overline{WDO} goes HIGH as soon as V_{CC} transitions above the threshold. There is no minimum pulse width for \overline{WDO} as there is for the RESET outputs. If WDI is floated, \overline{WDO} essentially acts as a low-power output indicator.

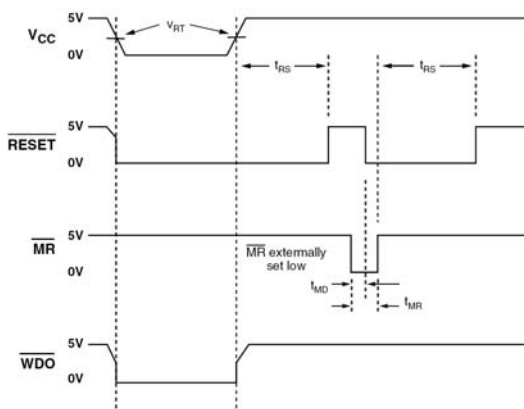

Figure 1. WDI Three-state operation

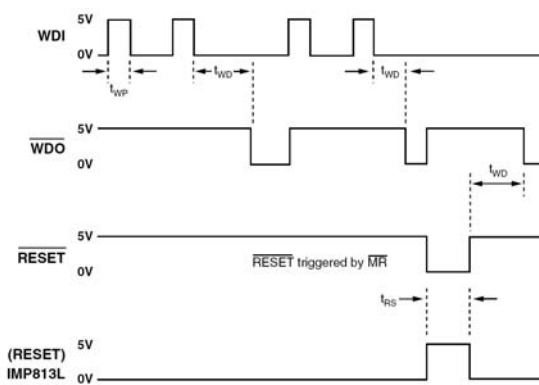

Figure 2. Watchdog Timing

APPLICATION INFORMATION

Ensuring That \overline{RESET} is Valid Down to $V_{CC} = 0V$

When V_{CC} falls below 1.1V, the MAX706/MAX706T/MAX706S/MAX706R \overline{RESET} output no longer pulls down; it becomes indeterminate. To avoid the possibility that stray charges build up and force \overline{RESET} to the wrong state, a pull-down resistor should be connected to the \overline{RESET} pin, thus draining such charges to ground and holding RESET low. The resistor value is not critical. A 100k Ω resistor will pull \overline{RESET} to ground without loading it.

Bi-directional Reset Pin Interfacing

The MAX706/MAX706T/MAX706S/MAX706R can interface with $\mu P/\mu C$ bi-directional reset pins by connecting a 4.7k Ω resistor in series with the \overline{RESET} output and the $\mu P/\mu C$ bi-directional \overline{RESET} pin.

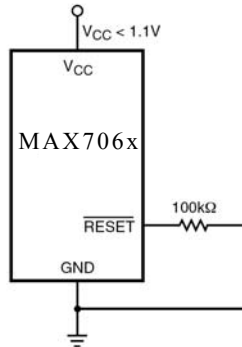

Figure 3. Ensuring That \overline{RESET} is Valid Down to $V_{CC} = 0V$

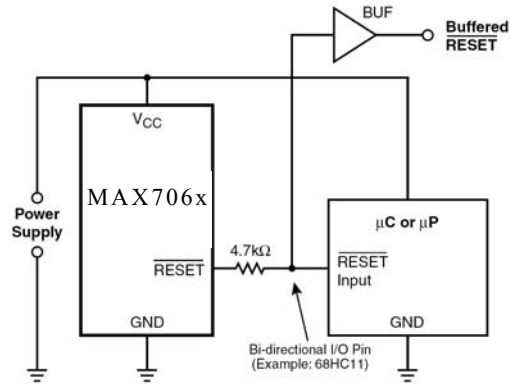

Figure 3. Bi-directional Reset Pin Interfacing

Monitoring Voltages Other Than Vcc

The MAX706/MAX706T/MAX706S/MAX706R can monitor voltages other than Vcc using the Power Fail circuitry. If a resistive divider is connected from the voltage to be monitored to the Power Fail input, PFI, the \overline{PFO} (output) will go LOW if the divider voltage goes below its 1.25V reference. Should hysteresis be desired, connect a resistor (equal to approximately 10 times the sum of the two resistors in the divider) between the PFI and \overline{PFO} pins. A capacitor between PFI and GND will reduce circuit sensitivity to input high-frequency noise. If it is desired to assert a RESET in addition to the \overline{PFO} flag, this may be achieved by connecting the \overline{PFO} output to \overline{MR} .

Monitoring a Negative Voltage

The Power-Fail circuitry can also monitor a negative supply rail. When the negative rail is OK, \overline{PFO} will be LOW, and when the negative rail is failing (not negative enough), \overline{PFO} goes HIGH (the opposite of when positive voltages are monitored). To trigger a reset, these outputs need to be inverted: adding the resistors and transistor as shown achieves this. The \overline{RESET} output will then have the same sense as for positive voltages: good = HIGH, bad = LOW. It should be noted that this circuit's accuracy depends on the Vcc line, the PFI threshold tolerance, and the resistors.

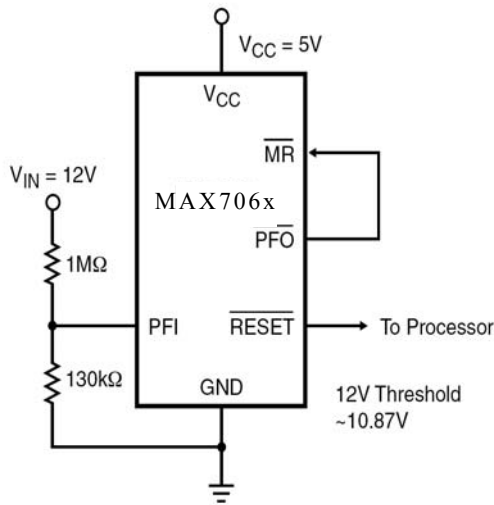

Figure 4. Monitoring Voltages Other Than V_{CC}

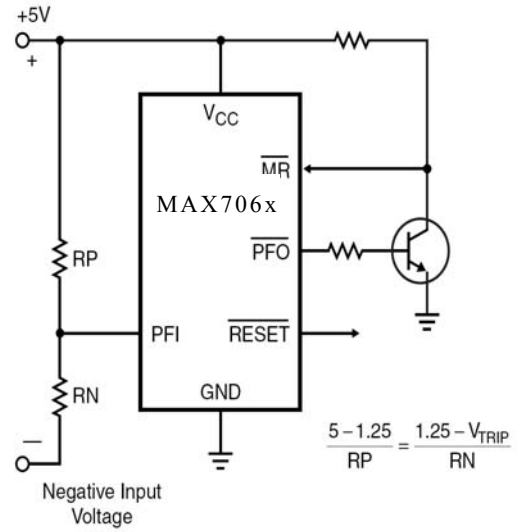
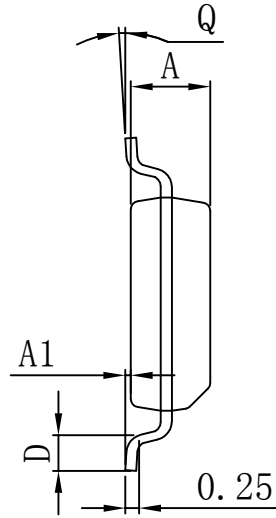
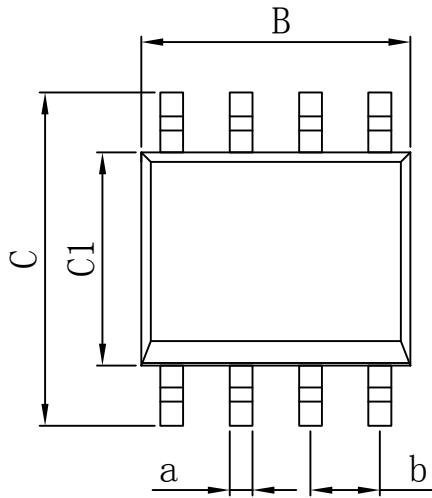

Figure 5. Monitoring a Negative Voltage

PACKAGE

SOP8



Dimensions In Millimeters					
Symbol :	Min :	Max :	Symbol :	Min :	Max :
A	1.225	1.570	D	0.400	0.950
A1	0.100	0.250	Q	0°	8°
B	4.800	5.100	a	0.420 TYP	
C	5.800	6.250	b	1.270 TYP	
C1	3.800	4.000			

DIP8

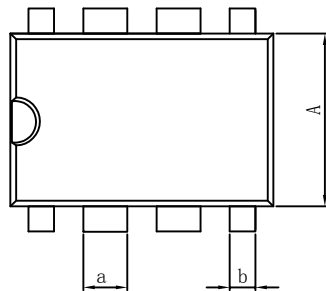
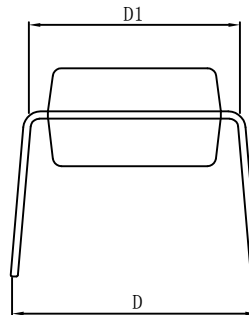
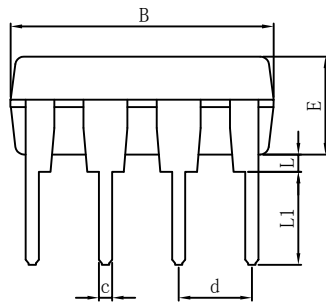

Dimensions In Millimeters					
Symbol :	Min :	Max :	Symbol :	Min :	Max :
A	6.100	6.680	L1	3.000	3.600
B	9.000	9.500	a	1.524 TYP	
D	8.400	9.000	b	0.889 TYP	
D1	7.420	7.820	c	0.457 TYP	
E	3.100	3.550	d	2.540 TYP	
L	0.500	0.700			

PACKAGE

MSOP8

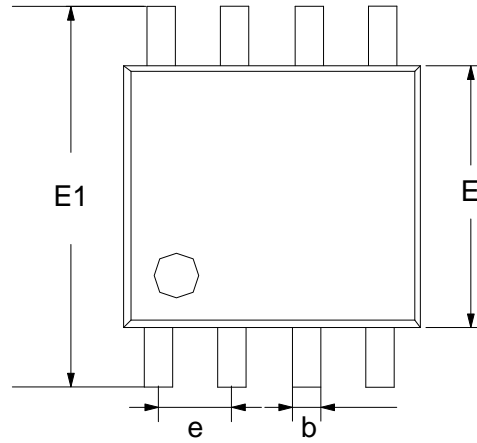
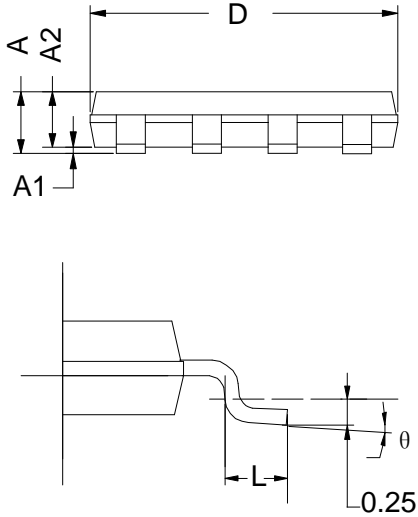

Dimensions In Millimeters					
Symbol :	Min :	Max :	Symbol :	Min :	Max :
A	0.800	1.200	E1	4.700	5.100
A1	0	0.200	L	0.410	0.650
A2	0.760	0.970	θ	0°	6°
D	2.900	3.100	b	0.300 TYP	
E	2.900	3.100	e	0.650 TYP	

Important statement:

Huaguan Semiconductor Co,Ltd. reserves the right to change the products and services provided without notice. Customers should obtain the latest relevant information before ordering, and verify the timeliness and accuracy of this information.

Customers are responsible for complying with safety standards and taking safety measures when using our products for system design and machine manufacturing to avoid potential risks that may result in personal injury or property damage.

Our products are not licensed for applications in life support, military, aerospace, etc., so we do not bear the consequences of the application of these products in these fields.

Our documentation is only permitted to be copied without any tampering with the content, so we do not accept any responsibility or liability for the altered documents.

X-ON Electronics

Largest Supplier of Electrical and Electronic Components

Click to view similar products for [Supervisory Circuits](#) category:

Click to view products by [HGSEMI](#) manufacturer:

Other Similar products are found below :

[NCP304LSQ40T1G](#) [CAT1161LI-25-G](#) [CAT853STBI-T3](#) [MCP1316MT-45GE/OT](#) [MCP1316MT-23LI/OT](#) [MCP1316T-26LE/OT](#) [DS1232L](#)
[NCV302HSN45T1G](#) [PT7M6130NLTA3EX](#) [S-1000N28-I4T1U](#) [CAT1161LI-28-G](#) [MCP1321T-29AE/OT](#) [MCP1320T-31KE/OT](#) [S-1000N23-I4T1U](#) [S-1000N19-I4T1U](#) [CAT824UTDI-GT3](#) [TC54VC2502ECB713](#) [MCP1317T-25LE/OT](#) [PT7M6133NLTA3EX](#) [PT7M6127NLTA3EX](#)
[BD48E23G-TR](#) [BD48E49G-TR](#) [BD48E52G-TR](#) [MP6412GQGU-Z](#) [XC61GN2502HR-G](#) [MB3793-37APNF-G-JN-ER6E1](#) [CPC5712U](#)
[LTC693CSW](#) [TC1232EOE](#) [TC1270ALVRCTR](#) [TC1270ANTVRCTR](#) [TC1271MERCCTR](#) [TC32MEZB](#) [TC54VN2102ECB713](#) [MB3793-27DPNF-G-JN-ERE1](#) [MCP100-460HITO](#) [MCP100-475HI/TO](#) [MCP100-485DI/TO](#) [MCP101-460HI/TO](#) [MCP101-475HI/TO](#)
[TCM809LVLB713](#) [TCM809SVLB713](#) [TCM810RVLB713](#) [MCP102-315E/TO](#) [MCP103T-300ELB](#) [MCP111-475E/TO](#) [MCP111T-300E/LB](#)
[MCP120-450HI/TO](#) [MCP120-475GITO](#) [MCP120-485DI/TO](#)