

## Low-Dropout Regulators

### Features

- High-current capability.....1.5A
- Low dropout voltage .....350mV
- Low ground current
- 1% initial accuracy
- Extremely fast transient response
- Reverse-battery and “load dump” protection
- Zero-current shutdown mode (5-pin versions)
- Error flag signals Output Out-of-Regulation (5-Pin versions)
- Fixed voltage and adjustable versions

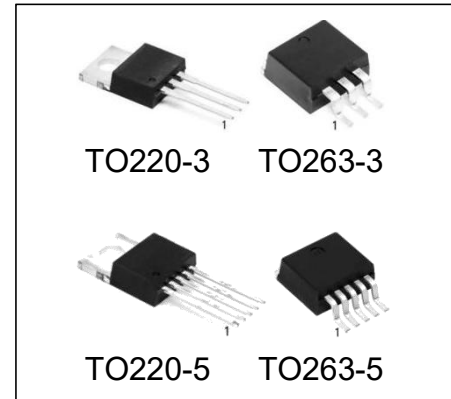

### Ordering Information

DEVICE	Package Type	MARKING	Packing	Packing Qty
MIC29150T-1.5	TO220-3L	MIC29150-1.5	TUBE	1000pcs/box
MIC29150T-1.8	TO220-3L	MIC29150-1.8	TUBE	1000pcs/box
MIC29150T-2.5	TO220-3L	MIC29150-2.5	TUBE	1000pcs/box
MIC29150T-2.8	TO220-3L	MIC29150-2.8	TUBE	1000pcs/box
MIC29150T-3.0	TO220-3L	MIC29150-3.0	TUBE	1000pcs/box
MIC29150T-3.3	TO220-3L	MIC29150-3.3	TUBE	1000pcs/box
MIC29150T-5.0	TO220-3L	MIC29150-5.0	TUBE	1000pcs/box
MIC29150T-8.0	TO220-3L	MIC29150-8.0	TUBE	1000pcs/box
MIC29150T-9.0	TO220-3L	MIC29150-9.0	TUBE	1000pcs/box
MIC29150T-12	TO220-3L	MIC29150-12	TUBE	1000pcs/box
MIC29150S-1.5/TR	TO263-3L	MIC29150-1.5	REEL	500pcs/reel
MIC29150S-1.8/TR	TO263-3L	MIC29150-1.8	REEL	500pcs/reel
MIC29150S-2.5/TR	TO263-3L	MIC29150-2.5	REEL	500pcs/reel
MIC29150S-2.8/TR	TO263-3L	MIC29150-2.8	REEL	500pcs/reel
MIC29150S-3.0/TR	TO263-3L	MIC29150-3.0	REEL	500pcs/reel
MIC29150S-3.3/TR	TO263-3L	MIC29150-3.3	REEL	500pcs/reel
MIC29150S-5.0/TR	TO263-3L	MIC29150-5.0	REEL	500pcs/reel
MIC29150S-8.0/TR	TO263-3L	MIC29150-8.0	REEL	500pcs/reel
MIC29150S-9.0/TR	TO263-3L	MIC29150-9.0	REEL	500pcs/reel
MIC29150S-12/TR	TO263-3L	MIC29150-12	REEL	500pcs/reel
MIC29151T-1.5	TO220-5L	MIC29151-1.5	TUBE	1000pcs/box
MIC29151T-1.8	TO220-5L	MIC29151-1.8	TUBE	1000pcs/box

MIC29151T-2.5	TO220-5L	MIC29151-2.5	TUBE	1000pcs/box
MIC29151T-2.8	TO220-5L	MIC29151-2.8	TUBE	1000pcs/box
MIC29151T-3.0	TO220-5L	MIC29151-3.0	TUBE	1000pcs/box
MIC29151T-3.3	TO220-5L	MIC29151-3.3	TUBE	1000pcs/box
MIC29151T-5.0	TO220-5L	MIC29151-5.0	TUBE	1000pcs/box
MIC29151T-8.0	TO220-5L	MIC29151-8.0	TUBE	1000pcs/box
MIC29151T-9.0	TO220-5L	MIC29151-9.0	TUBE	1000pcs/box
MIC29151T-12	TO220-5L	MIC29151-12	TUBE	1000pcs/box
MIC29151S-1.5/TR	TO263-5L	MIC29151-1.5	REEL	500pcs/reel
MIC29151S-1.8/TR	TO263-5L	MIC29151-1.8	REEL	500pcs/reel
MIC29151S-2.5/TR	TO263-5L	MIC29151-2.5	REEL	500pcs/reel
MIC29151S-2.8/TR	TO263-5L	MIC29151-2.8	REEL	500pcs/reel
MIC29151S-3.0/TR	TO263-5L	MIC29151-3.0	REEL	500pcs/reel
MIC29151S-3.3/TR	TO263-5L	MIC29151-3.3	REEL	500pcs/reel
MIC29151S-5.0/TR	TO263-5L	MIC29151-5.0	REEL	500pcs/reel
MIC29151S-8.0/TR	TO263-5L	MIC29151-8.0	REEL	500pcs/reel
MIC29151S-9.0/TR	TO263-5L	MIC29151-9.0	REEL	500pcs/reel
MIC29151S-12/TR	TO263-5L	MIC29151-12	REEL	500pcs/reel
MIC29152T	TO220-5L	MIC29152	TUBE	1000pcs/box
MIC29152S/TR	TO263-5L	MIC29152	REEL	500pcs/reel

## General Description

The MIC2915X(-XX) are high-current, high-accuracy, lowdropout voltage regulators. Using the process with a PNP pass element, these regulators feature 350mV (full load) dropout voltages and very low ground current. These devices also find applications in lower current, low-dropout critical systems, where their tiny dropout voltage and ground current values are important attributes.

The MIC2915X(-XX) are fully protected against over current faults, reversed input polarity, reversed lead insertion, over temperature operation, positive and negative transient voltage spikes. Five-pin fixed voltage versions feature a logic level ON/OFF control and an error flag, which signals whenever the output falls out of regulation.

On the MIC29151(-XX) and MIC29152 the EN (Enable) pin may be tied to  $V_{IN}$ , if it is not required for the ON/OFF control.

The MIC2915X(-XX) are available in 3- and 5-pin TO-220, TO-263 packages.

The Output Voltage, (-XX), may be 1.5V, 1.8V, 2.5V, 2.8V, 3V, 3.3V, 5V, 8V, 9V, 12V

## Applications

- Battery-powered equipment
- High-efficiency “green” computer systems
- Automotive electronics
- High-efficiency linear power supplies
- High-efficiency post-regulator for switching supply

## PIN Configuration

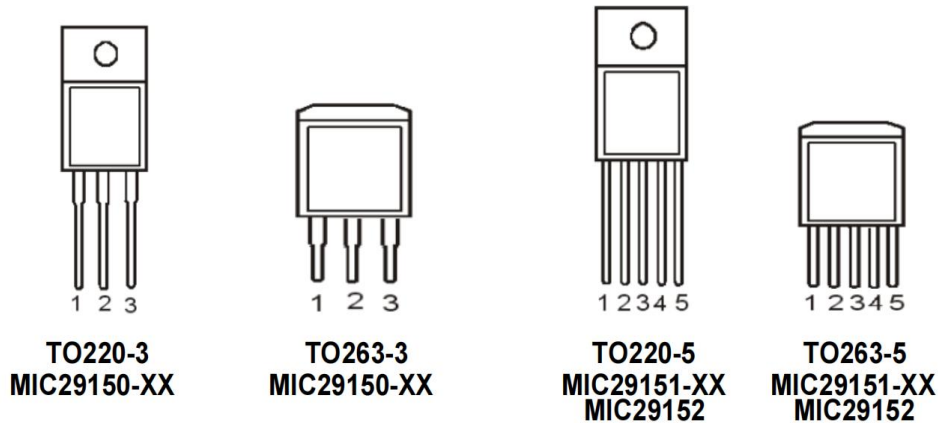

## Pinout

On all the devices, the Tab is grounded.

**MIC29150-XX**, three-terminal devices:

Pin 1 = IN (Input), 2 = GND (Ground), 3 = OUT (Output)

**MIC29151-XX**, five-terminal fixed voltage devices

Pin 1 = EN (Enable), 2 = IN (Input), 3 = GND (Ground), 4 = OUT (Output), 5 = FLAG (Flag)

**MIC29152**, adjustable version with ON/OFF control

Pin 1 = EN (Enable), 2 = IN (Input), 3 = GND (Ground), 4 = OUT (Output), 5 = ADJ (Adjust)

## Absolute Maximum Ratings

Condition	Min	Max	UNITS
Input Supply Voltage	-20	+30	V
Power Dissipation	internally-limited		-
Lead Temperature (soldering, 5 seconds)	-	260	°C
Storage Temperature Range	-65	+150	°C

## Operating Ratings

Condition	Min	Max	UNITS
Operating Input Voltage	2.3	26	V
Operating Junction Temperature	-40	+125	°C

## Electrical Characteristics

All measurements at  $T_J=25^{\circ}\text{C}$ ,  $I_O=10\text{mA}$ ,  $V_{IN}=V_{OUT}+1\text{V}$ , unless otherwise noted. **Bold** values are guaranteed across the operating temperature range. Adjustable versions are programmed to 5.0V.

Parameter	Conditions	Min	Typ	Max	Units
Output Voltage	$I_O=10\text{mA}$	<b>-1</b>		<b>1</b>	%
	$10\text{mA}\leq I_O\leq 1.5\text{A}$ , $(V_{OUT}+1\text{V})\leq V_{IN}\leq 26\text{V}$	<b>-2</b>		<b>2</b>	%
Line Regulation	$I_O=10\text{mA}$ , $(V_{OUT}+1\text{V})\leq V_{IN}\leq 26\text{V}$		0.06	0.5	%
Load Regulation	$V_{IN}=V_{OUT}+5\text{V}$ , $10\text{mA}\leq I_{OUT}\leq 1.5\text{A}$ (Note 1)		0.2	<b>1</b>	%
$\frac{\Delta V_O}{\Delta T}$	Output Voltage Temperature Coefficient (Note 2)		<b>20</b>	<b>100</b>	ppm/ $^{\circ}\text{C}$
Dropout Voltage	$V_{OUT}=-1\%$ , (Note 1, 3)				
	$I_O=100\text{mA}$		100	<b>200</b>	mV
	$I_O=750\text{mA}$		250		
	$I_O=1.5\text{A}$		350	<b>600</b>	
Ground Current	(Note 1, 4) $I_O=750\text{mA}$ , $V_{IN}=V_{OUT}+1\text{V}$ $I_O=1.5\text{A}$		8	<b>20</b>	mA
			22		
$I_{GNDDO}$ , GND Pin Current at Dropout	$V_{IN}=0.5\text{V}$ less than specified $V_{OUT}$ , $I_{OUT}=10\text{mA}$ (Note 5)		2		mA
Current Limit	MIC29150 $V_{OUT}=0\text{V}$ (Note 1)		2.1	<b>3.5</b>	$\mu\text{A}$
<b>Reference, MIC29152</b>					
Reference Voltage		1.228	1.240	1.252	V
		<b>1.215</b>		<b>1.265</b>	
Reference Voltage	(Note 6)	<b>1.203</b>		<b>1.277</b>	V
ADJ Pin Bias Current			20	80 <b>120</b>	nA
Reference Voltage Temperature Coefficient	(Note 2)		20		ppm/ $^{\circ}\text{C}$
ADJ Pin Bias Current Temperature Coefficient			0.1		nA/ $^{\circ}\text{C}$
<b>Flag Output (Error Comparator), MIC29151-XX</b>					
Output Leakage Current	$V_{OH}=26\text{V}$		0.01	1.00 <b>2.00</b>	$\mu\text{A}$
Output Low Voltage	$V_{IN}=0.5\text{V}$ less than specified $V_{OUT}$ , $I_{OL}=250\mu\text{A}$ (Note 5)		220	300 <b>400</b>	mV
Upper Threshold Voltage	(Note 5)			99.2	% of $V_{OUT}$
Lower Threshold Voltage	(Note 5)	93			% of $V_{OUT}$
Hysteresis	(Note 5)		1		% of $V_{OUT}$
<b>EN Input, MIC29151-XX, MIC29152</b>					
Input Logic Voltage Low (OFF) High (ON)		<b>2.4</b>		<b>0.8</b>	V
EN Pin Input Current	$V_{EN}=26\text{V}$		30	600 <b>750</b>	$\mu\text{A}$
	$V_{EN}=0.8\text{V}$			2.5 <b>5</b>	$\mu\text{A}$
Regulator Output Current Shutdown	(Note 7)		10	<b>500</b>	$\mu\text{A}$

**Notes:**

**Note 1:** Employ pulse-testing procedures to minimize temperature rise.

**Note 2:** Output Voltage temperature coefficient is defined as the worst case voltage change divided by the total temperature range.

**Note 3:** Dropout Voltage is defined as the input-to-output differential when the Output Voltage drops to 99% of its nominal value with  $V_{OUT}+1V$  applied to  $V_{IN}$ . For Output Voltages below 2.3V the Dropout Voltage is the input-to-output voltage differential with the minimum input voltage being 2.3V. The minimum input operation voltage is 2.3V.

**Note 4:** GND pin current is the regulator quiescent current. The total current drawn from the source is a sum of the load current plus the GND pin current.

**Note 5:** For specified  $V_{OUT} \geq 2.5V$ .

**Note 6:**  $V_{REF} \leq V_{OUT} \leq (V_{IN}-1V)$ ,  $2.3V \leq V_{IN} \leq 26V$ ,  $10mA \leq I_L \leq 1.5A$ ,  $T_J < T_J \text{ MAX}$ .

**Note 7:**  $V_{EN} \leq 0.8V$  and  $V_{IN} \leq 26V$ ,  $V_{OUT}=0$

**Note 8:** When used in dual supply systems, where the regulator load is returned to a negative supply, the output voltage must be diode-clamped to ground.

**Block Diagram**

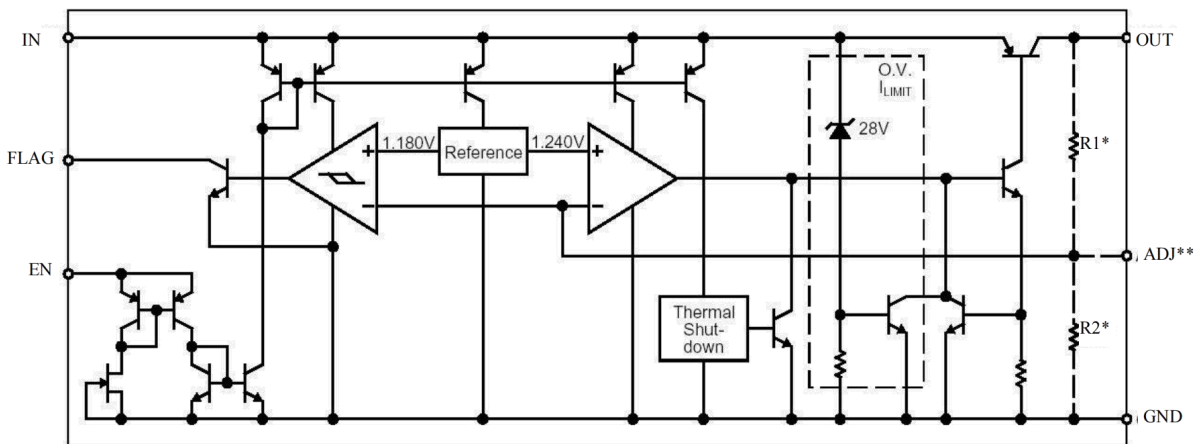

\*Feedback network in fixed versions only.  
\*\*Adjustable version only.

**Typical Applications**

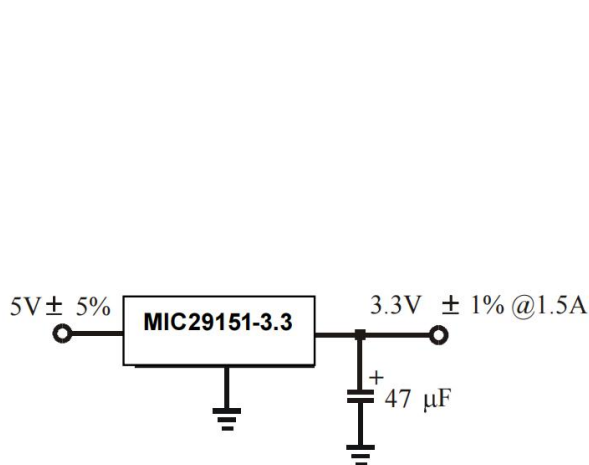

Fig.1. Fixed output voltage

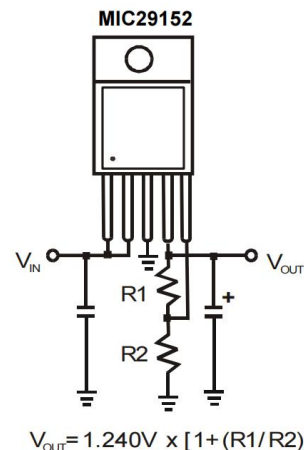

Fig.2. Adjustable output voltage configuration. For best results, the total series resistance should be small enough to pass the minimum regulator load current

## Application information

The MIC2915X(-XX) are high performance low-dropout voltage regulators suitable for all moderate to high-current voltage regulator applications. Their 350mV dropout voltage at full load makes them especially valuable in battery-powered systems and as high-efficiency noise filters in postregulator applications. Unlike older NPN-pass transistor designs, dropout performance of the PNP output of these devices is limited merely by the low VCE saturation voltage.

The MIC2915X(-XX) family of regulators is fully protected from the damage due to fault conditions. Current limiting is provided. This limiting is linear; output current under overload conditions is constant. Thermal shutdown disables the device when the die temperature exceeds the 125°C maximum safe operating temperature. The Transients protection allows the device survival even when the input voltage spikes between -20V and +30V. When the input voltage exceeds about 28V to 33V, the overvoltage sensor temporarily disables the regulator.

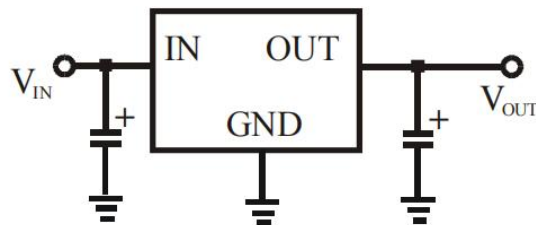

Fig.3. Linear regulators require only two capacitors for operation.

## Thermal Design

The linear regulators are simple to use. The most complicated design parameters to consider are thermal characteristics. Thermal design requires the following application-specific parameters:

- Maximum ambient temperature,  $T_A$
- Output Current,  $I_{OUT}$
- Output Voltage,  $V_{OUT}$
- Input Voltage,  $V_{IN}$

First, we calculate the power dissipation of the regulator from these numbers and the device parameters from this datasheet.

$$P_D = I_{OUT}(1.01V_{IN} - V_{OUT}),$$

where the ground current is approximated by 1% of  $I_{OUT}$

Then the heat sink thermal resistance is determined with this formula:

$$\theta_{SA} = \frac{T_{JMAX} - T_A}{P_D} - (\theta_{JC} + \theta_{CS}),$$

where  $T_{JMAX} \leq 125^\circ\text{C}$  and  $\theta_{CS}$  is between 0 and  $2^\circ\text{C/W}$ .

## Capacitor Requirements

For stability and minimum output noise, a capacitor on the regulator output is necessary. The value of this capacitor is dependent upon the output current; lower currents allow smaller capacitors. MIC2915X(-XX) regulators are stable with the 10 F minimum capacitor values at a full load.

Where the regulator is powered from a source with a high AC impedance, a  $0.1\mu\text{F}$  capacitor connected between Input and GND is recommended. This capacitor should have good characteristics to above 250kHz.

## Minimum Load Current

The MIC29150 regulators are specified between finite loads. If the output current is too small, leakage currents dominate and the output voltage rises. The 5mA minimum load current swamps any expected leakage current across the operating temperature range.

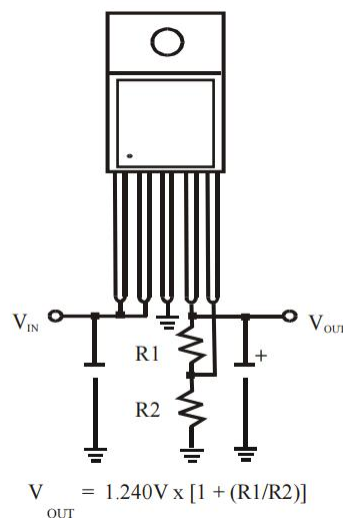

Fig.4. Adjustable Regulator with Resistors

## Adjustable Regulator Design

The adjustable regulator version, MIC29152 , allows one to program the output voltage anywhere between 1.25V and 26V (maximum operating rating of the family). Two resistors are used. Resistors can be quite large, up to 1M , because of the very high input impedance and low bias current of the sense comparator: The resistor values are calculated by:

$$R_1 = R_2 \left( \frac{V_{OUT}}{1.240} - 1 \right),$$

where  $V_{OUT}$  is the desired output voltage. Figure 4 shows component definition. Applications with widely varying load currents may scale the resistors to draw the minimum load current required for proper operation.

## Error Flag

The MIC29151-XX version features an Error Flag, which looks at the output voltage and signals an error condition when this voltage drops 5% below its expected value. The error flag is an open-collector output that pulls low under fault conditions. It may sink 10mA. Low output voltage signifies a number of possible problems, including an overcurrent fault (the device is in current limit) and a low input voltage. The flag output is inoperative during overtemperature shutdown conditions.

## Enable Input

MIC29151-XX and MIC29152 versions feature an enable (EN) input that allows ON/OFF control of the device. A special design allows “zero” current drain when the device is disabled - only microamperes of leakage current flow. The EN input has TTL/CMOS compatible thresholds for simple interfacing with logic, or may be directly tied to  $\leq 30V$ . Enabling the regulator requires approximately 20 $\mu A$  of current.



## Physical Dimensions

### TO263-3

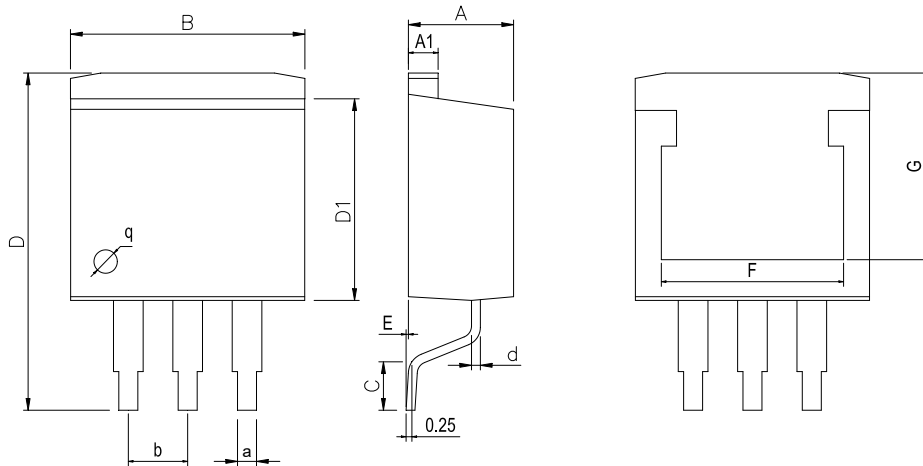

Dimensions In Millimeters(TO263-3)											
Symbol:	A	A1	B	C	D	D1	E	F	G	a	b
Min:	4.45	1.22	10	1.89	13.7	8.38	0	8.332	7.70	0.71	2.54BSC
Max:	4.62	1.32	10.4	2.19	14.6	8.89	0.305	8.552	8.10	0.97	

### TO220-3

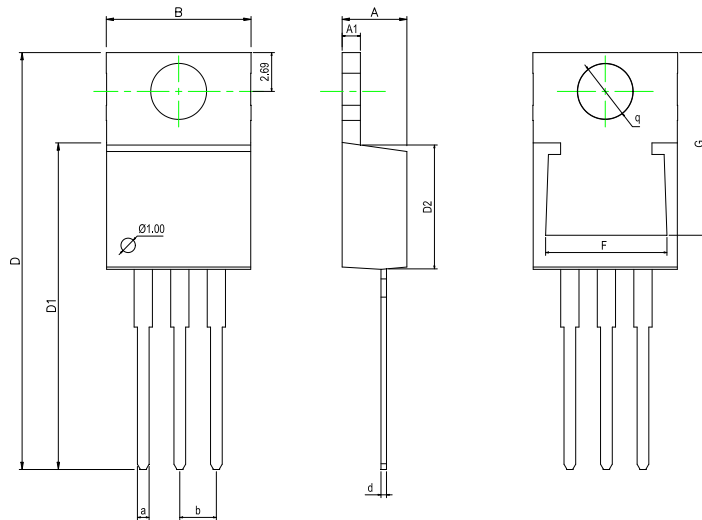

Dimensions In Millimeters(TO220-3)												
Symbol:	A	A1	B	D	D1	D2	F	G	a	d	b	q
Min:	4.45	1.22	10	28.2	22.22	8.50	8.30	12.55	0.71	0.33	2.54	3.80
Max:	4.62	1.32	10.4	28.9	22.62	9.10	8.55	12.75	0.97	0.42	BSC	TYP

## Physical Dimensions

### TO263-5

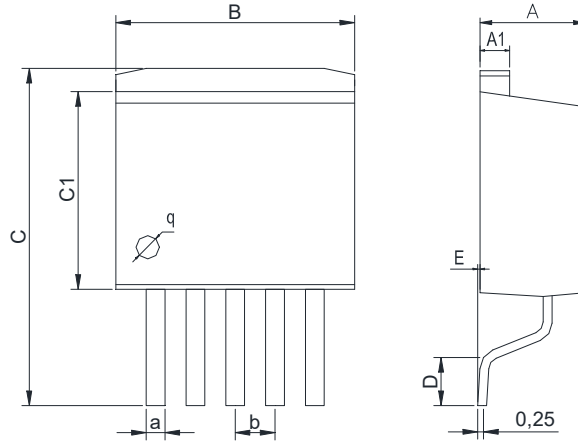

**Dimensions In Millimeters(TO263-5)**

Symbol:	A	A1	B	C	C1	D	E	a	b
Min:	4.45	1.22	10	13.7	8.40	1.90	0	0.71	1.70BSC
Max:	4.62	1.32	10.4	14.6	8.90	2.10	0.20	0.97	

### TO220-5

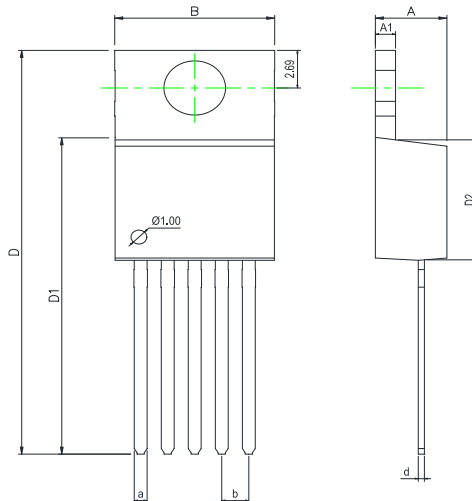

**Dimensions In Millimeters(TO220-5)**

Symbol:	A	A1	B	D	D1	D2	a	d	b
Min:	4.52	1.25	10	28.2	22.4	8.69	1.68	0.33	1.70BSC
Max:	4.62	1.29	10.3	28.9	22.6	8.79	1.77	0.42	

**IMPORTANT STATEMENT:**

Huaguan Semiconductor reserves the right to change its products and services without notice. Before ordering, the customer shall obtain the latest relevant information and verify whether the information is up to date and complete. Huaguan Semiconductor does not assume any responsibility or obligation for the altered documents.

Customers are responsible for complying with safety standards and taking safety measures when using Huaguan Semiconductor products for system design and machine manufacturing. You will bear all the following responsibilities: select the appropriate Huaguan Semiconductor products for your application; Design, validate and test your application; Ensure that your application meets the appropriate standards and any other safety, security or other requirements. To avoid the occurrence of potential risks that may lead to personal injury or property loss.

Huaguan Semiconductor products have not been approved for applications in life support, military, aerospace and other fields, and Huaguan Semiconductor will not bear the consequences caused by the application of products in these fields.

The technical and reliability data (including data sheets), design resources (including reference designs), application or other design suggestions, network tools, safety information and other resources provided for the performance of semiconductor products produced by Huaguan Semiconductor are not guaranteed to be free from defects and no warranty, express or implied, is made. The use of testing and other quality control technologies is limited to the quality assurance scope of Huaguan Semiconductor. Not all parameters of each device need to be tested.

The documentation of Huaguan Semiconductor authorizes you to use these resources only for developing the application of the product described in this document. You have no right to use any other Huaguan Semiconductor intellectual property rights or any third party intellectual property rights. It is strictly forbidden to make other copies or displays of these resources. You should fully compensate Huaguan Semiconductor and its agents for any claims, damages, costs, losses and debts caused by the use of these resources. Huaguan Semiconductor accepts no liability for any loss or damage caused by infringement.

## X-ON Electronics

Largest Supplier of Electrical and Electronic Components

*Click to view similar products for [LDO Voltage Regulators](#) category:*

*Click to view products by [HGSEMI](#) manufacturer:*

Other Similar products are found below :

[AP7363-SP-13](#) [L79M05TL-E](#) [AP7362-HA-7](#) [PT7M8202B12TA5EX](#) [TCR3DF185,LM\(CT](#) [TCR3DF45,LM\(CT](#) [TLE4473G V52](#)  
[NCP4687DH15T1G](#) [701326R](#) [NCV8170AXV250T2G](#) [AP7315-25W5-7](#) [AP2111H-1.2TRG1](#) [ZLDO1117QK50TC](#) [AZ1117ID-ADJTRG1](#)  
[TCR3DG12,LF](#) [MIC5514-3.3YMT-T5](#) [SCD7912BTG](#) [NCP154MX180270TAG](#) [SCD33269T-5.0G](#) [NCV8170BXV330T2G](#)  
[NCV8170BMX330TCG](#) [NCV8170AMX120TCG](#) [NCP706ABMX300TAG](#) [NCP114BMX075TCG](#) [MC33269T-3.5G](#) [TCR3DG33,LF](#)  
[TLE4471GXT](#) [TCR4DG35,LF](#) [TAR5S15U\(TE85L,F\)](#) [TCR3UG19A,LF](#) [TCR4DG105,LF](#) [MPQ2013AGG-5-P](#) [NCV8170AMX360TCG](#)  
[AP7315-33SA-7](#) [TLE4268GSXUMA2](#) [NCP715SQ15T2G](#) [MIC5317-3.0YD5-T5](#) [NCV563SQ18T1G](#) [NCP715MX30TBG](#)  
[NCV8702MX25TCG](#) [NCV8170BXV120T2G](#) [MIC5317-1.2YD5-T5](#) [NCV8170AMX150TCG](#) [NCV8170BMX150TCG](#) [AP2213D-3.3TRG1](#)  
[NCV8170BMX120TCG](#) [NCV8170BMX310TCG](#) [NCV8170BMX360TCG](#) [MIC5514-1.2YMT-T5](#) [NCV8170BMX280TCG](#)