

FEATURES

- 3A minimum guaranteed output current
- 500mV typical dropout at 3A
 - Ideal for 3.0V to 2.5V conversion
 - Ideal for 2.5V to 1.8V or 1.5V conversion
- 1% initial accuracy
- Low ground current
- Current limiting and thermal shutdown
- Reversed-battery protection
- Reversed-leakage protection
- Fast transient response
- TTL/CMOS compatible enable pin => MIC29301
- Error flag output - MIC29301 only
- Adjustable version - MIC29302 only
- TO-263 and TO-220 packaging
- Moisture Sensitivity Level 3

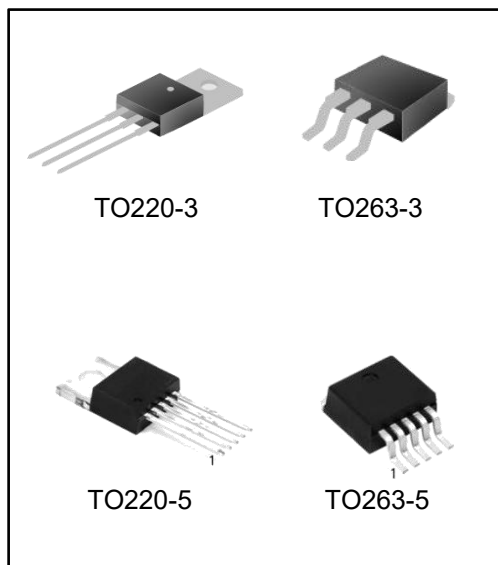

ORDERING INFORMATION

DEVICE	Package Type	MARKING	Packing	Packing Qty
MIC29300T-1.5	TO220-3	MIC29300-1.5	TUBE	1000pcs/box
MIC29300T-1.8	TO220-3	MIC29300-1.8	TUBE	1000pcs/box
MIC29300T-2.5	TO220-3	MIC29300-2.5	TUBE	1000pcs/box
MIC29300T-3.3	TO220-3	MIC29300-3.3	TUBE	1000pcs/box
MIC29300T-5.0	TO220-3	MIC29300-5.0	TUBE	1000pcs/box
MIC29300S-1.5/TR	TO263-3	MIC29300-1.5	REEL	500pcs/reel
MIC29300S-1.8/TR	TO263-3	MIC29300-1.8	REEL	500pcs/reel
MIC29300S-2.5/TR	TO263-3	MIC29300-2.5	REEL	500pcs/reel
MIC29300S-3.3/TR	TO263-3	MIC29300-3.3	REEL	500pcs/reel
MIC29300S-5.0/TR	TO263-3	MIC29300-5.0	REEL	500pcs/reel
MIC29301T-1.5	TO220-5	MIC29301-1.5	TUBE	1000pcs/box
MIC29301T-1.8	TO220-5	MIC29301-1.8	TUBE	1000pcs/box
MIC29301T-2.5	TO220-5	MIC29301-2.5	TUBE	1000pcs/box
MIC29301T-3.3	TO220-5	MIC29301-3.3	TUBE	1000pcs/box
MIC29301T-5.0	TO220-5	MIC29301-5.0	TUBE	1000pcs/box
MIC29301S-1.5/TR	TO263-5	MIC29301-1.5	REEL	500pcs/reel
MIC29301S-1.8/TR	TO263-5	MIC29301-1.8	REEL	500pcs/reel
MIC29301S-2.5/TR	TO263-5	MIC29301-2.5	REEL	500pcs/reel
MIC29301S-3.3/TR	TO263-5	MIC29301-3.3	REEL	500pcs/reel
MIC29301S-5.0/TR	TO263-5	MIC29301-5.0	REEL	500pcs/reel
MIC29302T	TO220-5	MIC29302	TUBE	1000pcs/box
MIC29302S/TR	TO263-5	MIC29302	REEL	500pcs/reel

DESCRIPTION

The MIC29300, MIC29301 and MIC29302 are 3.0A low-dropout linear voltage regulators that provide a low voltage, high-current output with a minimum of external components.

The MIC29300/1 offers extremely low dropout (typically 400mV at 3.0A) and low ground current (typically 36mA at 3.0A).

The MIC29300/1/2 is ideal for PC add-in cards that need to convert from standard 5V or 3.3V down to new, lower core voltages. A guaranteed maximum dropout voltage of 500mV over all operating conditions allows the MIC29300/1/2 to provide 2.5V from a supply as low as 3V.

The MIC29300/1/2 also has fast transient response for heavy switching applications. The device requires only 47F of output capacitance to maintain stability and achieve fast transient response. The MIC29300/1 is fully protected with over current limiting, thermal shutdown, reversed-battery protection, reversed-leakage protection, and reversed-lead insertion. The MIC29301 offers a TTL-logic compatible enable pin and an error flag that indicates under voltage and over current conditions. Offered in fixed voltages, the MIC29300/1/2 comes in the TO-220 and TO-263 packages and is an ideal upgrade to older, NPN-based linear voltage regulators.

APPLICATIONS

- LDO linear regulator for PC add-in cards
- High-efficiency linear power supplies
- Multimedia and PC processor supplies
- SMPS post regulator
- Low-voltage microcontrollers
- StrongARM™ processor supply

Typical Application Circuit

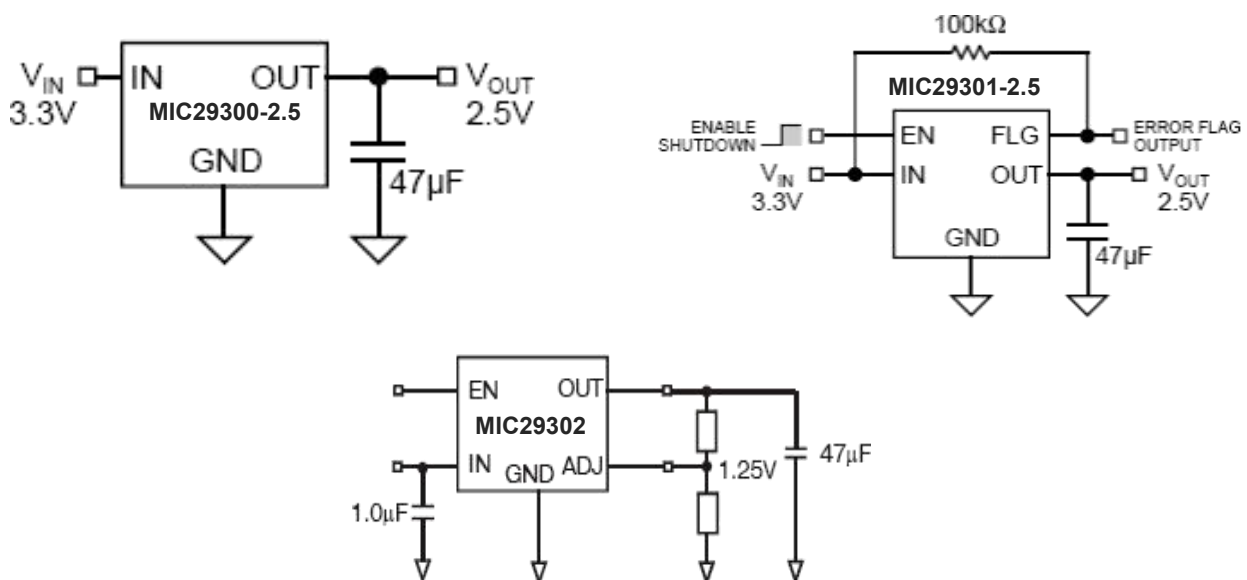

PIN DESCRIPTION

MIC29300-XX

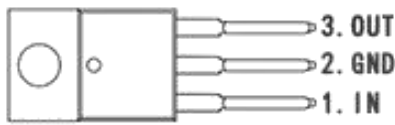

TO263-3

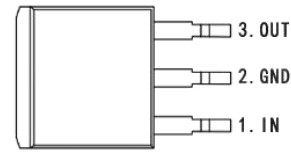

TO220-3

MIC29301-XX

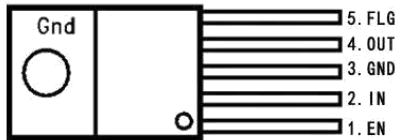

TO263-5

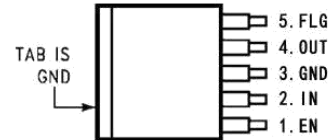

TO220-5

MIC29302

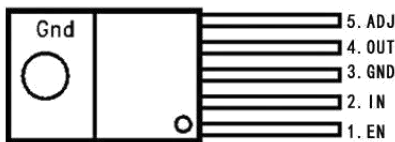

TO263-5

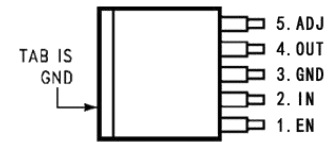

TO220-5

Pin Number MIC29300	Pin Number MIC29301	Pin Number MIC29302	Pin Name	Pin Name
-	1	1	EN	CMOS-compatible control input. Logic high = enable, logic Logic low or open = Shutdown
1	2	2	IN	Supply (Input): +16V maximum supply
2	3	3	GND	Ground pin and TAB are internally connected.
3	4	4	OUT	Regulator Output
-	-	5	ADJ	Adjustment Input: Feedback input.
-	5	-	FLG	Flag (Output): Open-collector error flag output.

* X.X = Fixed Vout = 1.5V, 1.8V, 2.5V, 3.3V, 5.0V

Absolute Maximum Ratings

Symbol	Parameter	Value	Unit
V _{IN}	Supply Voltage	-20 to +20	V
V _{EN}	Enable Voltage	+20	V
T _s	Storage Temperature	-65 to +150	°C
ESD	Lead Temperature (soldering, 5 sec)	260	°C

Operating Ratings

Symbol	Parameter	Value	Unit
V _{IN}	Supply Voltage	+2.25 to +16	V
V _{EN}	Enable Voltage	+16	V
PD(max)	Maximum Power Dissipation	Note 4	
T _J	Junction Temperature	-40 to +125	°C
Package Thermal Resistance			
θ _{JC}	TO-263	5	°C/W
θ _{JC}	TO-220	2	°C/W

Block Diagram

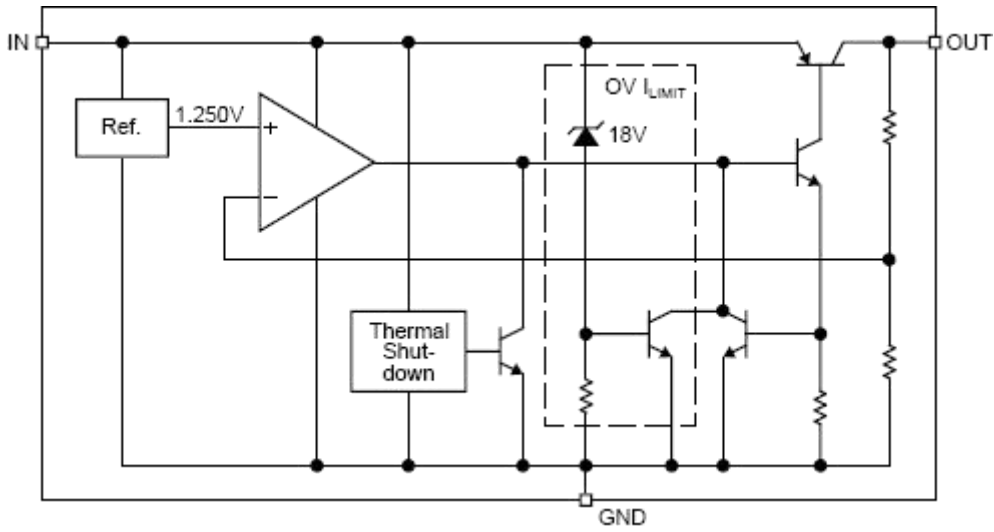

MIC29300 Fixed (1.5V,1.8V,2.5V,3.3V,5.0V)

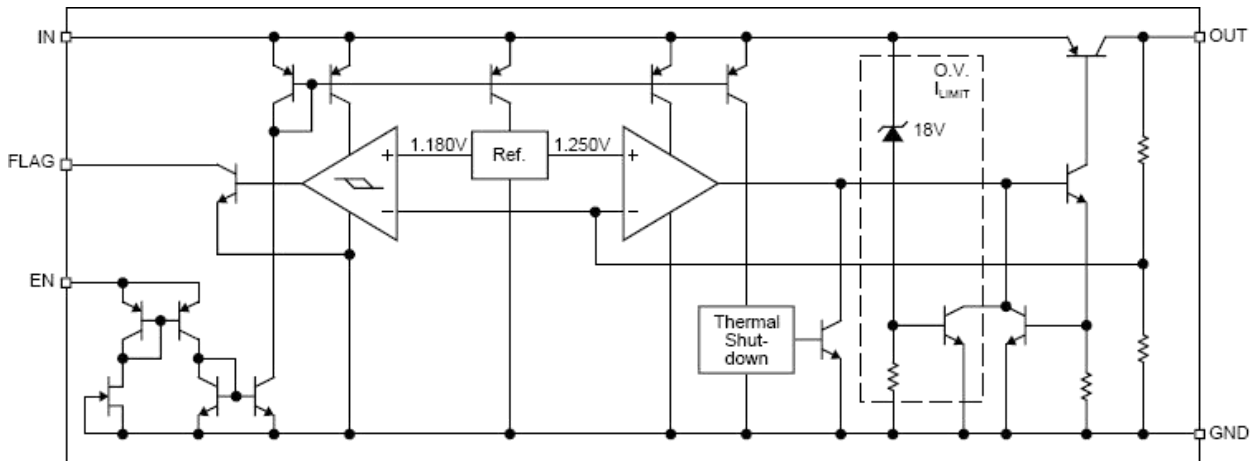

MIC29301 Fixed with Flag and Enable

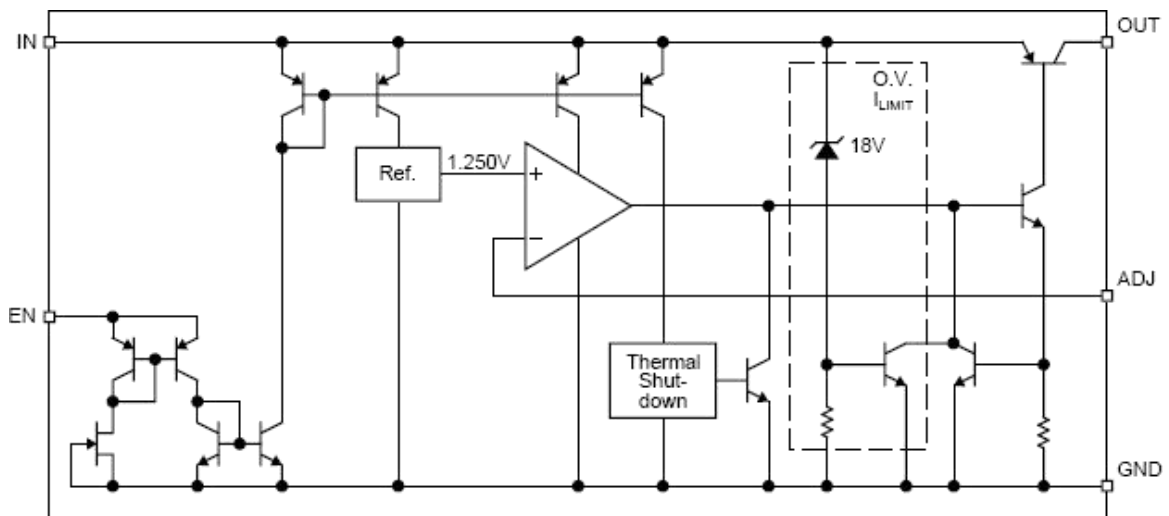

MIC29302 Adjustable

Electrical Characteristics

$T_J=25^{\circ}\text{C}$, bold values indicate $-40^{\circ}\text{C} \leq T_J \leq +125^{\circ}\text{C}$: unless noted

Symbol	Parameter	Conditions	Min	Typ	Max	Units
V _{OUT}	Output Voltage	10mA	-1		1	%
		$10\text{mA} \leq I_{\text{OUT}} \leq 3\text{A}, V_{\text{OUT}}+1\text{V} \leq V_{\text{IN}} \leq 8\text{V}$	-2		2	%
-	Line Regulation	$I_{\text{OUT}}=10\text{mA}, V_{\text{OUT}}+1\text{V} \leq V_{\text{IN}} \leq 8\text{V}$	-	0.06	0.5	%
-	Line Regulation	$V_{\text{IN}}=V_{\text{OUT}}+1\text{V}, 10\text{mA} \leq I_{\text{OUT}} \leq 3\text{A}$	-	0.2	1	%
$\Delta V_{\text{OUT}}/\Delta T$	Output Voltage Temp. Coefficient, Note5		-	20	100	ppm/ $^{\circ}\text{C}$
V _{DD}	Dropout Voltage, Note6	$I_{\text{OUT}}=100\text{mA}, \Delta V_{\text{OUT}}=-1\%$	-	80	200	mV
		$I_{\text{OUT}}=750\text{mA}, \Delta V_{\text{OUT}}=-1\%$	-	200	-	mV
		$I_{\text{OUT}}=1.5\text{A}, \Delta V_{\text{OUT}}=-1\%$	-	320	-	mV
		$I_{\text{OUT}}=3\text{A}, \Delta V_{\text{OUT}}=-1\%$	-	400	500	mV
I _{GND}	Ground Current, Note7	$I_{\text{OUT}}=750\text{mA}, V_{\text{IN}}=V_{\text{OUT}}+1\text{V}$		10	20	mA
		$I_{\text{OUT}}=1.5\text{A}, V_{\text{IN}}=V_{\text{OUT}}+1\text{V}$		17		mA
		$I_{\text{OUT}}=3\text{A}, V_{\text{IN}}=V_{\text{OUT}}+1\text{V}$		45		mA
I _{GND(do)}	Dropout Ground Pin Current	$V_{\text{IN}} \leq V_{\text{OUT(nomina)}}-0.5\text{V}, I_{\text{OUT}}=10\text{mA}$		6		mA
I _{OUT(lim)}	Current Limit	$V_{\text{OUT}}=0\text{V}, V_{\text{IN}}=V_{\text{OUT}}+1\text{V}$		4.5		A
Enable Input(MIC29301)						
V _{EN}	Enable Input Voltage	logic low(off)			0.8	V
		logic high(on)	2.25			V
I _{IN}	Enable Input Current	$V_{\text{EN}}=V_{\text{IN}}$		15	30 75	μA μA
		$V_{\text{EN}}=0.8\text{V}$			2 4	μA μA
I _{OUT(shdn)}	Shutdown Output Current	Note8		10	20	μA
Flag Output(MIC29301)						
I _{FLG(leak)}	Output Leakage Current	$V_{\text{OH}}=16\text{V}$		0.01	1 2	μA μA
V _{FLG(do)}	Output Low Voltage	$V_{\text{IN}}=2.250\text{V}, I_{\text{OL}}=250\mu\text{A}, \text{Note9}$		220	300 400	mV mV
V _{FLG}	Low Threshold	% of V _{OUT}	93			%
	High Threshold				99.2	%
	Hysteresis			1		%
MIC29302 Only						
	Reference Voltage	Note10	1.238	1.250	1.262	V
			1.225		1.275	V
			1.213		1.227	V
	Adjust Pin Bias Current			40	80 120	nA nA
	Reference Voltage Temp. Coefficient	Note7		20		ppm/ $^{\circ}\text{C}$
	Adjust Pin Vias Current Temp. Coefficient			0.1		nA/ $^{\circ}\text{C}$

Note 1. Exceeding the absolute maximum ratings may damage the device.

Note 2. The device is not guaranteed to function outside its operating rating.

Note 3. Devices are ESD sensitive. Handling precautions recommended.

Note 4. $P_{\text{D(max)}} = (T_{\text{J(max)}} - T_{\text{A}}) \theta_{\text{JA}}$, where θ_{JA} depends upon the printed circuit layout. See "Applications Information."

Note 5. Vout temperature coefficient is $\Delta V_{\text{OUT(worst case)}} / (T_{\text{J(max)}} - T_{\text{J(min)}})$ where $T_{\text{J(max)}}$ is $+125^{\circ}\text{C}$ and $T_{\text{J(min)}}$ is 0°C

Note 6. $V_{\text{DO}} = V_{\text{IN}} - V_{\text{OUT}}$ when VOUT decreases to 99% of its nominal output voltage with $V_{\text{IN}} = V_{\text{OUT}} + 1\text{V}$.

Note 7. I_{GND} is the quiescent current. $I_{\text{IN}} = I_{\text{GND}} + I_{\text{OUT}}$.

Note 8. V_{EN} 0.8V, V_{IN} 8V, and V_{OUT} = 0V

Note 9. For a 2.5V device, V_{IN} = 2.250V (device is in dropout).

Note 10. $V_{\text{REF}} \leq V_{\text{OUT}} \leq (V_{\text{IN}} - 1\text{V}), 2.25\text{V} \leq V_{\text{IN}} \leq 16\text{V}, 10\text{mA} \leq I_{\text{L}} \leq 3\text{A}, T_{\text{J}} = T_{\text{MAX}}$.

TYPICAL PERFORMANCE CHARACTERISTICS

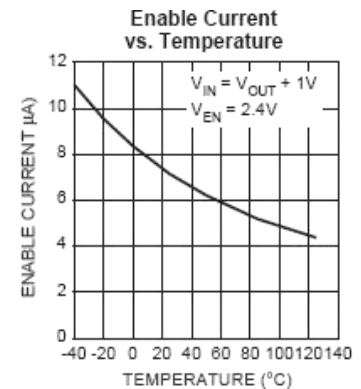
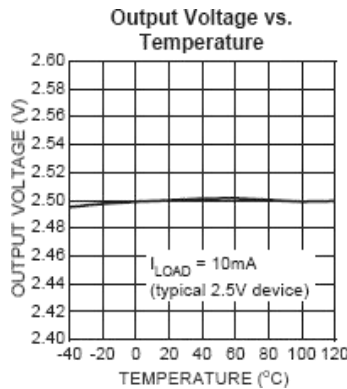
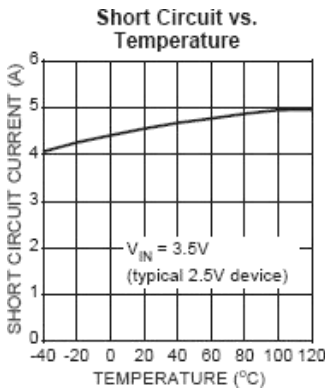
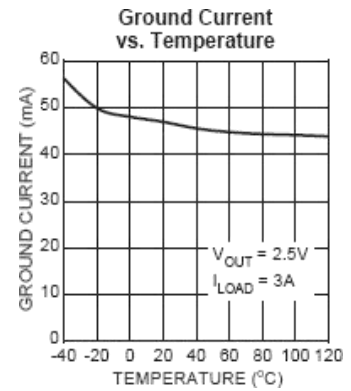
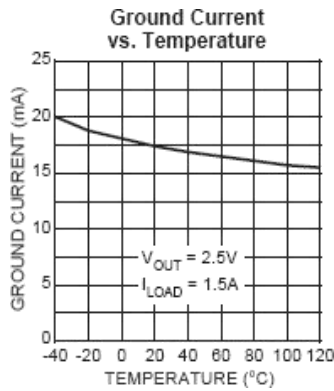
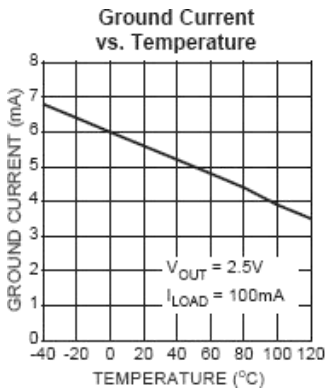
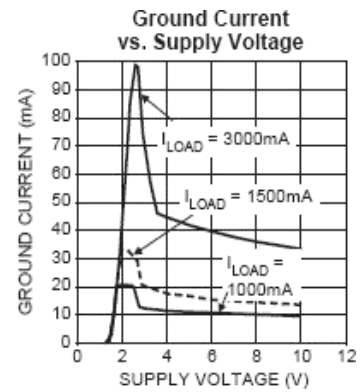
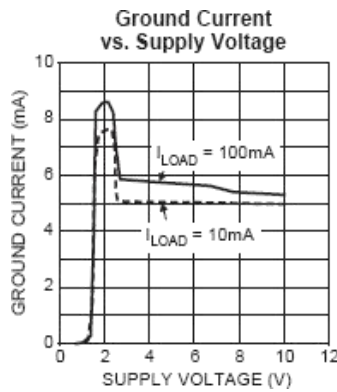
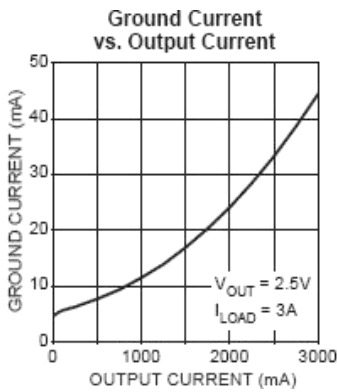
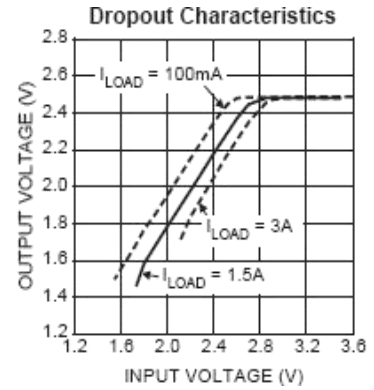
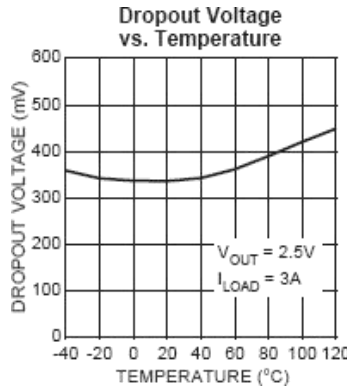
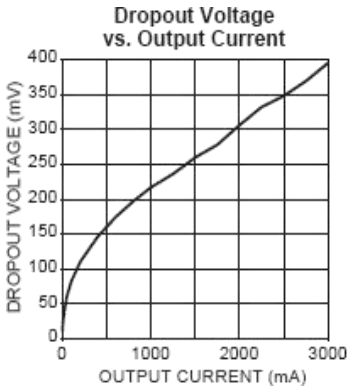

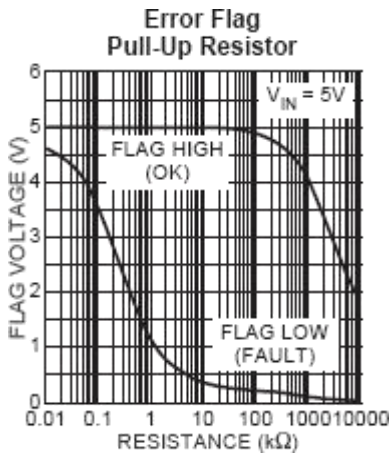
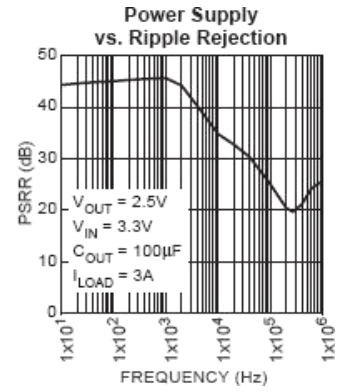
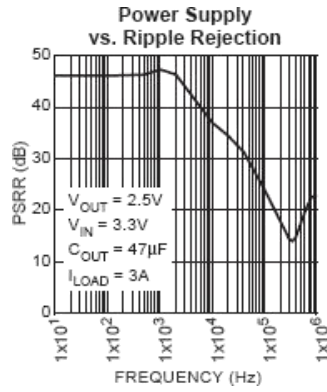
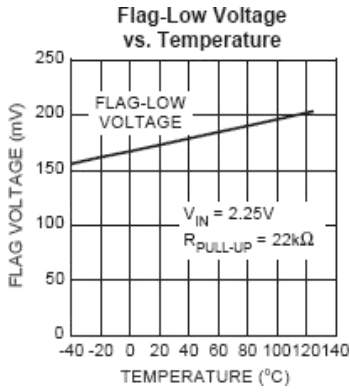

Line Transient Response

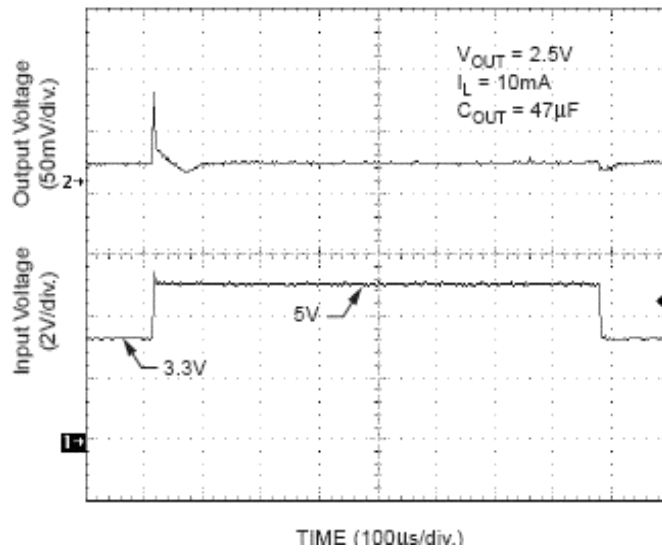

APPLICATION INFORMATION

The MIC29300/1 is a high-performance low-dropout voltage regulator suitable for moderate to high-current voltage regulator applications. Its 500mV dropout voltage at full load makes it especially valuable in battery-powered systems and as a high-efficiency noise filter in post-regulator applications. Unlike older NPN-pass transistor designs, where the minimum dropout voltage is limited by the base-to-emitter voltage drop and collector-to-emitter saturation voltage, dropout performance of the PNP output of these devices is limited only by the low V_{CE} saturation voltage. A trade-off for the low dropout voltage is a varying base drive requirement. The MIC29300/1/2 regulator is fully protected from damage due to fault conditions. Current limiting is provided. This limiting is linear output current during overload conditions is constant. Thermal shutdown disables the device when the die temperature exceeds the maximum safe operating temperature. Transient protection allows device (and load) survival even when the input voltage spikes above and below nominal. The output structure of these regulators allows voltages in excess of the desired output voltage to be applied without reverse current flow.

Thermal Design

Linear regulators are simple to use. The most complicated design parameters to consider are thermal characteristics. Thermal design requires four application-specific parameters:

Maximum ambient temperature (T_A)

- Output Current (I_{OUT})
- Output Voltage (V_{OUT})
- Input Voltage (V_{IN})
- Ground Current (I_{GND})

Calculate the power dissipation of the regulator from these numbers and the device parameters from this datasheet, where the ground current is taken from the data sheet.

$$P_D = (V_{IN} - V_{OUT}) I_{OUT} + V_{IN} \cdot I_{GND}$$

The heat sink thermal resistance is determined by:

$$\theta_{SA} = (T_{JMAX} - T_A) / P_D - (\theta_{JC} + \theta_{CS})$$

where T_J (max) = 125 °C and θ_{CS} is between 0°C and 2°C/W.

The heat sink may be significantly reduced in applications where the minimum input voltage is known and is large compared with the dropout voltage. Use a series input resistor to drop excessive voltage and distribute the heat between this resistor and the regulator. The low dropout properties of Taijin regulators allow significant reductions in regulator power dissipation and the associated heat sink without compromising performance. When this technique is employed, a capacitor of at least 1.0F is needed directly between the input and regulator ground. Refer to Application Note 9 for further details and examples on thermal design and heat sink specification.

Output Capacitor

The MIC29300/1/2 requires an output capacitor to maintain stability and improve transient response. Proper capacitor selection is important to ensure proper operation. The MIC29300/1/2 output capacitor selection is dependent upon the ESR (equivalent series resistance) of the output capacitor to maintain stability. When the output capacitor is 47F or greater, the output capacitor should have less than 1 of ESR. This will improve transient response as well as promote stability. Ultralow ESR capacitors, such as ceramic chip capacitors may promote instability. These very low ESR levels may cause an oscillation and/or underdamped transient response. A low-ESR solid tantalum capacitor works extremely well and provides good transient response and stability over temperature. Aluminum electrolytics can also be used, as long as the ESR of the capacitor is < 1. The value of the output capacitor can be increased without limit. Higher capacitance values help to improve transient response and ripple rejection and reduce output noise.

Input Capacitor

An input capacitor of 1F or greater is recommended when the device is more than 4 inches away from the bulk ac supply capacitance, or when the supply is a battery. Small, surface-mount, ceramic chip capacitors can be used for the bypassing. Larger values will help to improve ripple rejection by bypassing the input to the regulator, further improving the integrity of the output voltage. Transient Response and 3.3V.

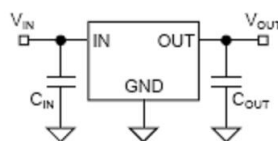

Fig 1. MIC29301-XX capacitor Requirements

Minimum Load Current

The MIC29300/1/2 regulator is specified between finite loads.

If the output current is too small, leakage currents dominate and the output voltage rises. A 10mA minimum load current is necessary for proper regulation.

Transient Response and 3.3V to 2.5V Conversion

The MIC29300/1/2 has excellent transient response to variations in input voltage and load current. The device has been designed to respond quickly to load current variations and input voltage variations. Large output capacitors are not required to obtain this performance. A standard 47F output capacitor, preferably tantalum, is all that is required. Larger values help to improve performance even further. By virtue of its low-dropout voltage, this device does not saturate into dropout as readily as similar NPN-based designs. When converting from 3.3V to 2.5V, the NPN-based regulators are already operating in dropout, with typical dropout requirements of 1.2V or greater. To convert down to 2.5V without operating in dropout, NPN-based regulators require an input voltage of 3.7V at the very least. The MIC29300/1/2 regulator will provide excellent performance with an input as low as 3.0V. This gives the PNP-based regulators a distinct advantage over older, NPN-based linear regulators.

Error Flag

The MIC29301 version features an error flag circuit which monitors the output voltage and signals an error condition when the voltage drops 5% below the nominal output voltage. The error flag is an open-collector output that can sink 10mA during a fault condition. Low output voltage can be caused by a number of problems, including an overcurrent fault (device in current limit) or low input voltage. The flag is inoperative during overtemperature shutdown.

Enable Input

The MIC29301 version features an enable input for on/off control of the device. Its shutdown state draws “zero” current (only microamperes of leakage). The enable input is TTL/ CMOS compatible for simple logic interface, but can be connected to up to 20V. When enabled, it draws approximately 15A.

Adjustable Regulator Design

The MIC29302 allows programming the output voltage anywhere between 1.25V and the 16V maximum operating rating of the family. Two resistors are used. Resistors can be quite large, up to 1M Ω , because of the very high input impedance and low bias current of the sense comparator: The resistor values are calculated by : $R1=R2(V_{out}/1.250- 1)$

Where V_O is the desired output voltage. Figure 1 shows component definition. Applications with widely varying load currents may scale the resistors to draw the minimum load current required for proper operation (see below).

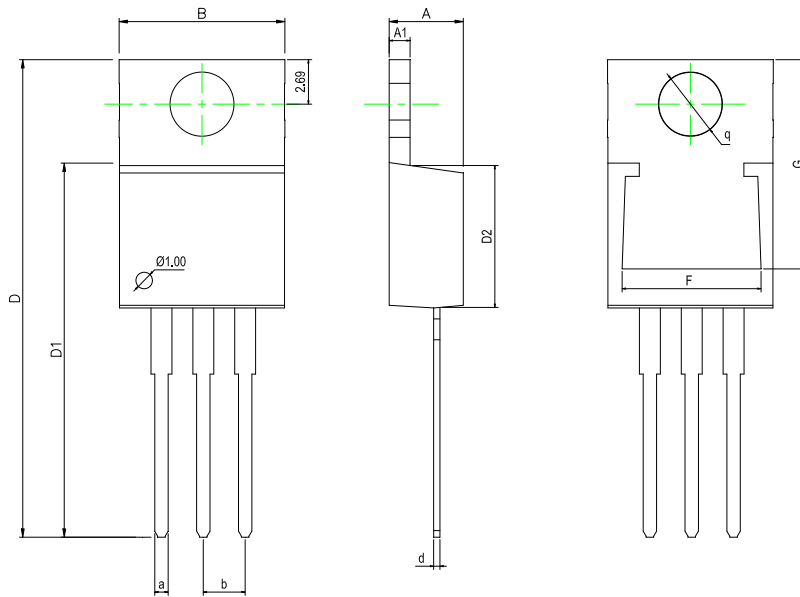
Physical Dimensions
TO220-3

Dimensions In Millimeters(TO220-3)

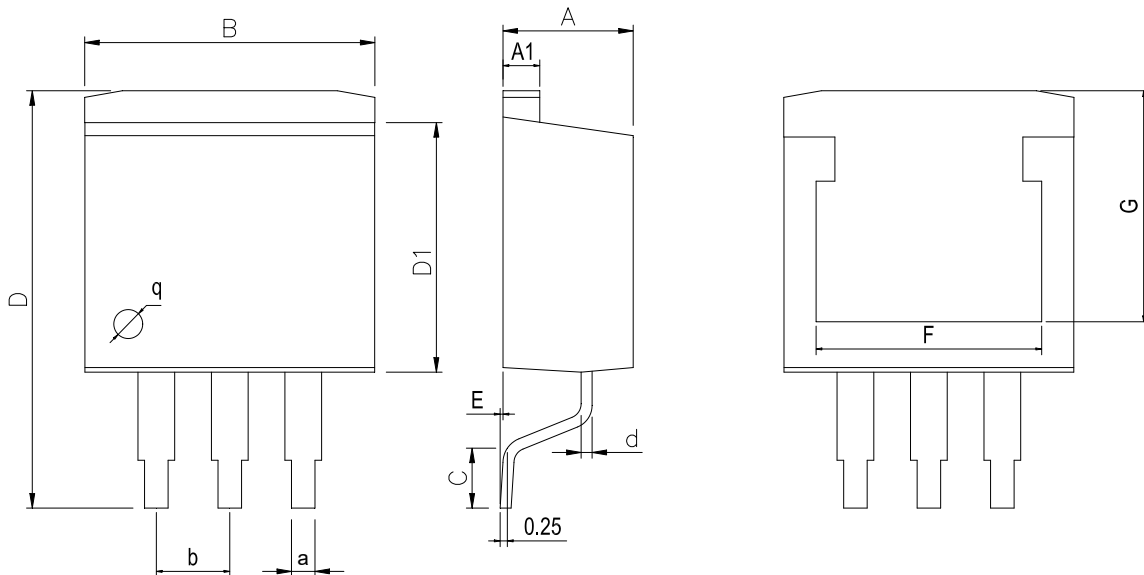
Symbol:	A	A1	B	D	D1	D2	F	G	a	d	b	q
Min:	4.45	1.22	10	28.2	22.22	8.50	8.30	12.55	0.71	0.33	2.54	3.80
Max:	4.62	1.32	10.4	28.9	22.62	9.10	8.55	12.75	0.97	0.42	BSC	TYP

TO263-3

Dimensions In Millimeters(TO263-3)

Symbol:	A	A1	B	C	D	D1	E	F	G	a	b
Min:	4.45	1.22	10	1.89	13.7	8.38	0	8.332	7.70	0.71	2.54BSC
Max:	4.62	1.32	10.4	2.19	14.6	8.89	0.305	8.552	8.10	0.97	

Physical Dimensions

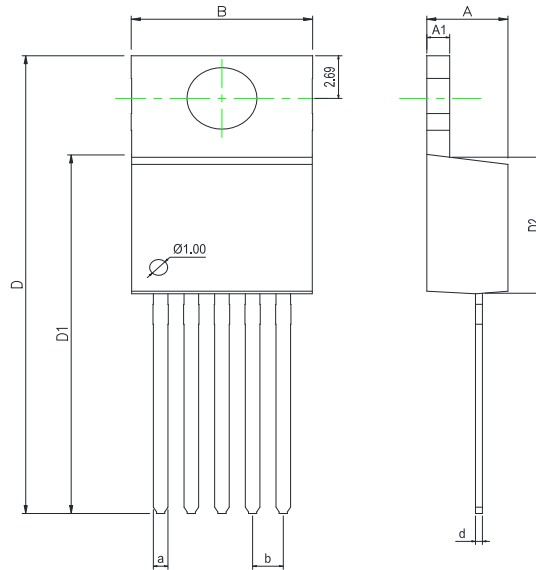
TO220-5

Dimensions In Millimeters(TO220-5)

Symbol:	A	A1	B	D	D1	D2	a	d	b
Min:	4.52	1.25	10	28.2	22.4	8.69	1.68	0.33	1.70BSC
Max:	4.62	1.29	10.3	28.9	22.6	8.79	1.77	0.42	

TO263-5

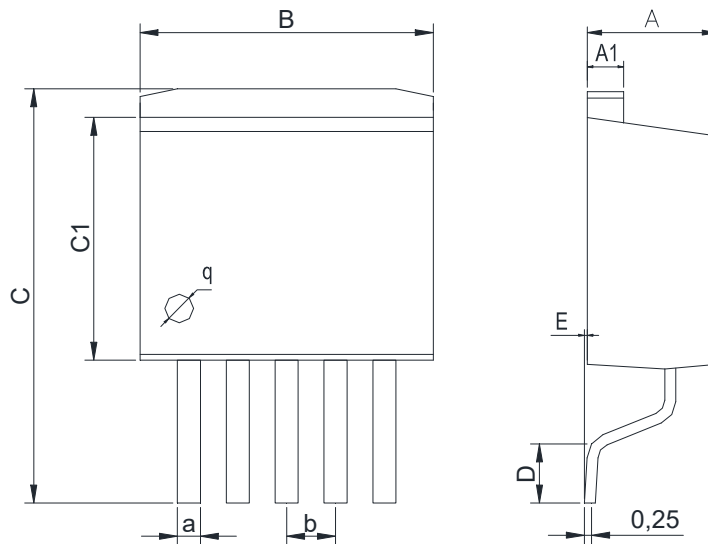
Dimensions In Millimeters(TO263-5)

Symbol:	A	A1	B	C	C1	D	E	a	b
Min:	4.45	1.22	10	13.7	8.40	1.90	0	0.71	1.70BSC
Max:	4.62	1.32	10.4	14.6	8.90	2.10	0.20	0.97	

IMPORTANT STATEMENT:

Huaguan Semiconductor reserves the right to change its products and services without notice. Before ordering, the customer shall obtain the latest relevant information and verify whether the information is up to date and complete. Huaguan Semiconductor does not assume any responsibility or obligation for the altered documents.

Customers are responsible for complying with safety standards and taking safety measures when using Huaguan Semiconductor products for system design and machine manufacturing. You will bear all the following responsibilities: Select the appropriate Huaguan Semiconductor products for your application; Design, validate and test your application; Ensure that your application meets the appropriate standards and any other safety, security or other requirements. To avoid the occurrence of potential risks that may lead to personal injury or property loss.

Huaguan Semiconductor products have not been approved for applications in life support, military, aerospace and other fields, and Huaguan Semiconductor will not bear the consequences caused by the application of products in these fields. All problems, responsibilities and losses arising from the user's use beyond the applicable area of the product shall be borne by the user and have nothing to do with Huaguan Semiconductor, and the user shall not claim any compensation liability against Huaguan Semiconductor by the terms of this Agreement.

The technical and reliability data (including data sheets), design resources (including reference designs), application or other design suggestions, network tools, safety information and other resources provided for the performance of semiconductor products produced by Huaguan Semiconductor are not guaranteed to be free from defects and no warranty, express or implied, is made. The use of testing and other quality control technologies is limited to the quality assurance scope of Huaguan Semiconductor. Not all parameters of each device need to be tested.

The documentation of Huaguan Semiconductor authorizes you to use these resources only for developing the application of the product described in this document. You have no right to use any other Huaguan Semiconductor intellectual property rights or any third party intellectual property rights. It is strictly forbidden to make other copies or displays of these resources. You should fully compensate Huaguan Semiconductor and its agents for any claims, damages, costs, losses and debts caused by the use of these resources. Huaguan Semiconductor accepts no liability for any loss or damage caused by infringement.

X-ON Electronics

Largest Supplier of Electrical and Electronic Components

Click to view similar products for [Linear Voltage Regulators](#) category:

Click to view products by [HGSEMI](#) manufacturer:

Other Similar products are found below :

[LV5684PVD-XH](#) [MCDTSA6-2R](#) [L7815ACV-DG](#) [LV56801P-E](#) [UA7805CKC](#) [714954EB](#) [ZMR500QFTA](#) [BA033LBSG2-TR](#)
[NCV78M05ABDTRKG](#) [LV5680P-E](#) [L79M05T-E](#) [L78LR05D-MA-E](#) [NCV317MBTG](#) [NTE7227](#) [MP2018GZD-33-P](#) [MP2018GZD-5-P](#)
[LV5680NPVC-XH](#) [ZTS6538SE](#) [UA78L09CLP](#) [UA78L09CLPR](#) [CAT6221-PPTD-GT3](#) [MC78M09CDTRK](#) [NCV51190MNTAG](#)
[BL1118CS8TR1833](#) [BL8077CKETR33](#) [BL9153-33CC3TR](#) [BL9161G-28BADRN](#) [BRCO7530MMC](#) [CJ7815B-TFN-ARG](#) [LM317C](#)
[GM7333K](#) [GM7350K](#) [XC6206P332MR](#) [HT7533](#) [LM7912S/TR](#) [LT1764S/TR](#) [LM7805T](#) [LM338T](#) [LM1117IMP-3.3/TR](#) [HT1117AM-3.3](#)
[HT7550S](#) [AMS1117-3.3](#) [HT7150S](#) [78L12](#) [HT7550](#) [HT7533-1](#) [HXY6206I-2.5](#) [HT7133](#) [HT7533S](#) [662K](#)