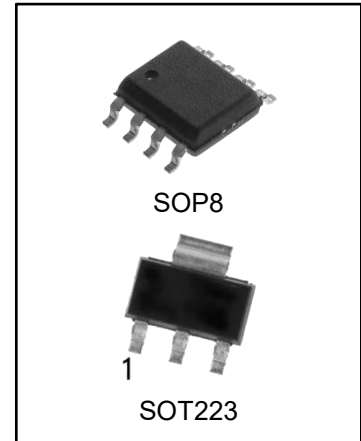


1A LOW- VOLTAGE LOW-DROPOUT REGULATOR

FEATURES

- Fixed and adjustable (to 1.24V) output voltages
- 410mV typical dropout at 1A
 Ideal for 3.0V to 2.5V conversion
 Ideal for 2.5V to 1.8V conversion
- 1A minimum guaranteed output current
- 1% initial accuracy
- Low ground current
- Current limiting and thermal shutdown
- Reversed-battery protection
- Reversed-leakage protection
- Fast transient response



ORDERING INFORMATION

DEVICE	Package Type	MARKING	Packing	Packing Qty
MIC39100MP-1.5/TR	SOT223	39100-1.5	REEL	2500pcs/reel
MIC39100MP-1.8/TR	SOT223	39100-1.8	REEL	2500pcs/reel
MIC39100MP-2.5/TR	SOT223	39100-2.5	REEL	2500pcs/reel
MIC39100MP-3.3/TR	SOT223	39100-3.3	REEL	2500pcs/reel
MIC39100MP-5.0/TR	SOT223	39100-5.0	REEL	2500pcs/reel
MIC39101M-1.5/TR	SOP8	39101-1.5	REEL	2500pcs/reel
MIC39101M-1.8/TR	SOP8	39101-1.8	REEL	2500pcs/reel
MIC39101M-2.5/TR	SOP8	39101-2.5	REEL	2500pcs/reel
MIC39101M-3.3/TR	SOP8	39101-3.3	REEL	2500pcs/reel
MIC39101M-5.0/TR	SOP8	39101-5.0	REEL	2500pcs/reel
MIC39102M/TR	SOP8	39302	REEL	2500pcs/reel

GENERAL DESCRIPTION

The MIC39100, MIC39101 and MIC39102 are 1A low-dropout linear voltage regulators that provide low-voltage, high-current output from an extremely small package. The MIC39100/1/2 offers extremely low dropout (typically 410mV at 1A) and low ground current (typically 12mA at 1A).

The MIC39100 is a fixed output regulator offered in the SOT-223 package. The MIC39101 and MIC39102 are fixed and adjustable regulators, respectively, in a thermally enhanced power 8-lead SOP (small outline package).

The MIC39100/1/2 is ideal for PC add-in cards that need to convert standard 5V to 3.3V, 3.3V to 2.5V or 2.5V to 1.8V. A guaranteed maximum dropout voltage of 630mV over all operating conditions allows the MIC39100/1/2 to provide 2.5V from a supply as low as 3.13V and 1.8V from a supply as low as 2.43V.

The MIC39100/1/2 is fully protected with overcurrent limiting, thermal shutdown, and reversed-battery protection. Fixed voltages of 5.0V, 3.3V, 2.5V, 1.8 and 1.5V are available on MIC39100/1, while the adjustable output voltages to 1.24V - on MIC39102.

APPLICATIONS

- LDO linear regulators for PC add-in cards
- High-efficiency linear power supplies
- SMPS post regulator
- Multimedia and PC processor supplies
- Battery chargers
- Low-voltage microcontrollers and digital logic

TYPICAL APPLICATION

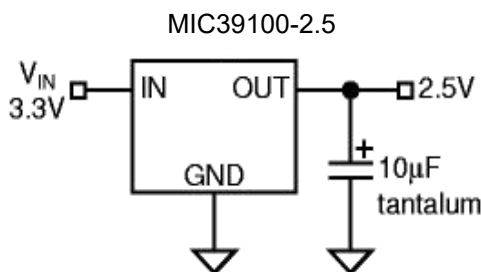


Fig.1a. 2.5V/1A regulator

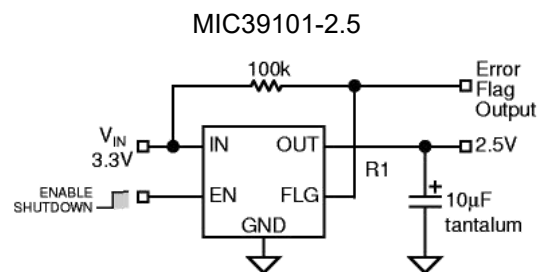


Fig.1b. 2.5V/1A regulator with an Error Flag

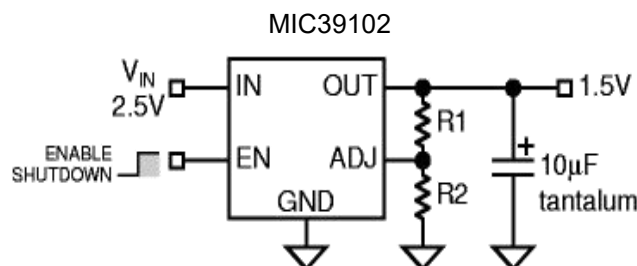


Fig.1c. 1.5V/1A adjustable regulator

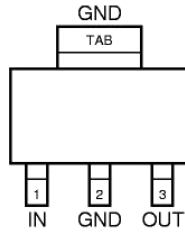
PIN CONFIGURATION


Fig.2a. MIC39100-XX, fixed, SOT-223

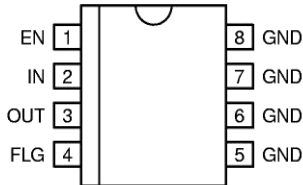


Fig.2b. MIC39101-XX, fixed, SOP8

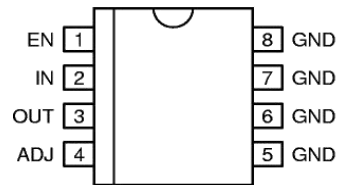


Fig.2c. MIC39102, adjustable, SOP8

PIN DESCRIPTION

PIN			NAME	FUNCTION
MIC39100	MIC39101	MIC39102		
1	1	1	EN	Enable (input): CMOS compatible control input. Logic High = enable; Logic Low or Open = shut-down.
	2	2	IN	Supply (input)
3	3	3	OUT	Regulator output
	4		FLG	Flag (output): Open collector error flag output. Active Low =output undervoltage.
		4	ADJ	Adjustment input: feedback input. Connect to resistive voltage-divider network.
2, TAB	5 - 8	5 - 8	GND	Ground

ABSOLUTE MAXIMUM RATINGS (Note 1)

PARAMETER		MIN	MAX	UNIT
V_{IN}	Supply voltage	-20	+20	V
V_{EN}	Enable voltage	-	+20	V
T_{STG}	Storage temperature	-65	+150	°C
-	Lead temperature (soldering, 5 sec.)	260		°C
-	ESD, <i>Note 3</i>			

RECOMMENDED OPERATION CONDITIONS (Note 2)

PARAMETER		MIN	MAX	UNIT
V _{IN}	Supply voltage	+2.25	+16	V
V _{EN}	Enable voltage	+2.25	+16	V
P _{D_Max}	Maximum power dissipation	-	-	-
T _J	Junction temperature	-40	+125	°C
Package thermal resistance:				
θ _{JC}	SOT-223	15		°C/W
θ _{JC}	SOP-8	20		°C/W

ELECTRICAL CHARACTERISTICS

V_{IN} = V_{OUT}+1V; V_{EN} = 2.25V; T_J = 25°C, **bold** values indicate -40°C ≤ T_J ≤ +125°C, unless noted.

SYMBOL	PARAMETERS	CONDITIONS	MIN.	TYP.	MAX.	UNIT
V _{OUT}	Output voltage	10mA	-1		+1	%
		10mA ≤ I _{OUT} ≤ 1A, V _{OUT} +1V ≤ V _{IN} ≤ 8V	-2		+2	%
L _{NR}	Line regulation	I _{OUT} = 10mA, V _{OUT} +1V ≤ V _{IN} ≤ 16V		0.06	0.5	%
L _{DR}	Load regulation	V _{IN} = V _{OUT} +1V, 10mA ≤ I _{OUT} ≤ 1A		0.2	1	%
V _{OUT} /T	Output voltage temperature coefficient, Note 5			40	100	ppm/°C
V _{DO}	Dropout voltage, Note 6	I _{OUT} = 100mA, V _{OUT} = -1%		150	200 250	mV
		I _{OUT} = 500mA, V _{OUT} = -1%		275		mV
		I _{OUT} = 750mA, V _{OUT} = -1%		330	500	mV
		I _{OUT} = 1A, V _{OUT} = -1%		410	550 630	mV
I _{GND}	Ground current, Note 7	I _{OUT} = 100mA, V _{IN} = V _{OUT} +1V		700		μA
		I _{OUT} = 500mA, V _{IN} = V _{OUT} +1V		4		mA
		I _{OUT} = 750mA, V _{IN} = V _{OUT} +1V		7		mA
		I _{OUT} = 1A, V _{IN} = V _{OUT} +1V		12	20	mA
I _{OUT(lim)}	Current limit	V _{OUT} = 0V, V _{IN} = V _{OUT} +1V		1.8	2.5	μA
t _{ON}	Turn-on time			1.3	5	ms

Enable input

V _{EN}	Enable input voltage	Logic Low (off)			0.8	V
		Logic High (on)	2.25			
I _{EN}	Enable input current	V _{EN} =2.25V	1	15	30 75	μA
		V _{EN} =0.8V			2 4	μA

Flag output

I _{FLG(leak)}	Output leakage current	V _{OH} = 16V		0.01	1 2	μA
V _{FLG(do)}	Output low voltage, Note 8	V _{IN} = 0.9 × V _{OUT} (Nominal), I _{OL} = 250μA		240	300 400	mV
V _{FLG}	Low threshold	% of V _{OUT}	93			%
	High threshold	% of V _{OUT}			99.2	
	Hysteresis			1		

MIC39102 , only

	Reference voltage		1.228 1.215	1.240	1.252 1.265	V
		Note 9	1.203		1.277	V
	ADJ pin bias current			40	80 120	nA
	Reference voltage temperature coefficient, Note 5			20		ppm/°C
	ADJ pin bias current temperature coefficient			0.1	99.2	nA/°C

Note 1. Exceeding the absolute maximum ratings may damage the device

Note 2. The device is not guaranteed to function outside its operating rating.

Note 3. Devices are ESD sensitive. Handling precautions are recommended.

Note 4. $P_{D_Max} = (T_{J_Max} - T_A) \times \theta_{JA}$, where θ_{JA} is junction-to-ambient thermal resistance.

Note 5. Output voltage temperature coefficient is V_{OUT} (worst case) $\times (T_{J_Max} - T_{J_Min})$
 where T_{J_Max} is +125°C and T_{J_Min} is -40°C.

Note 6. $V_{DO} = V_{IN} - V_{OUT}$ when V_{OUT} decreases to 99% of its nominal output voltage with $V_{IN} = V_{OUT} + 1V$. For output voltages below 2.25V, the dropout voltage is the input-to-output voltage differential with the minimum input voltage being 2.25V. The minimum input operating voltage is 2.25V.

Note 7. I_{GND} is the quiescent current. $I_{IN} = I_{GND} + I_{OUT}$

Note 8. For adjustable device and fixed device with $V_{OUT} \geq 2.5V$

Note 9. $V_{REF} \leq V_{OUT} \leq (V_{IN} - 1V)$, $2.25V \leq V_{IN} \leq 16V$, $10mA \leq I_L \leq 1A$.

FUNCTIONAL DIAGRAM

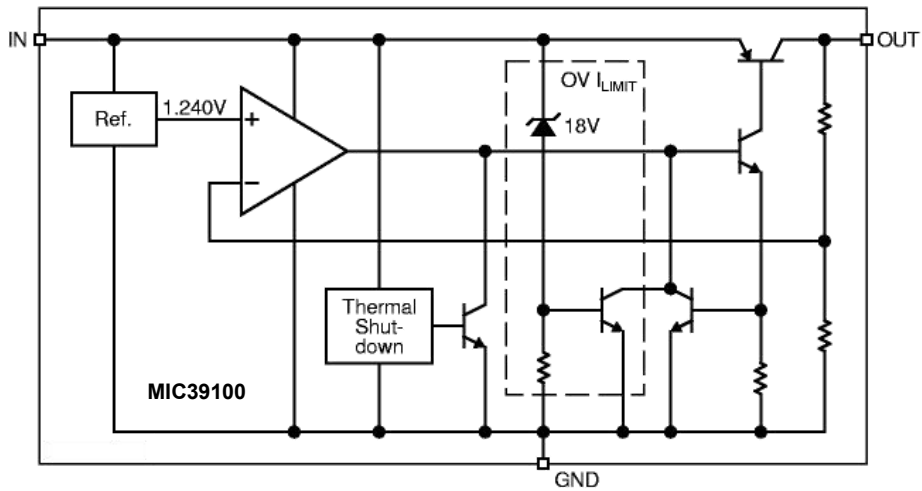


Fig.3. Block-diagram of MIC39100 fixed regulator

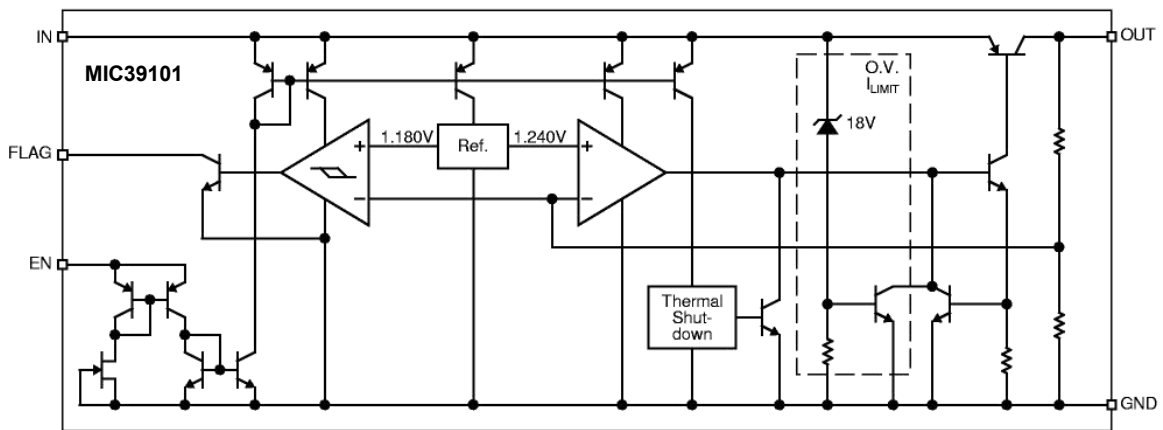


Fig.4. Block-diagram of MIC39101 fixed regulator with Flag and Enable Block

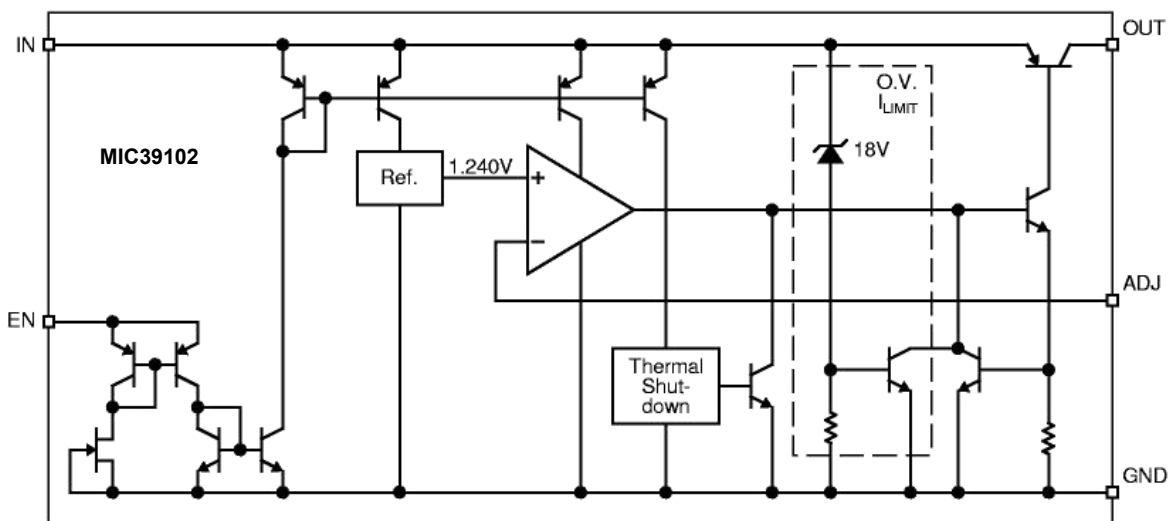


Fig.5. Block-diagram of MIC39102 adjustable regulator

APPLICATION INFORMATION

The MIC39100/1/2 is a high-performance low-dropout voltage regulator suitable for moderate-to high-current voltage regulator applications. Its 630mV dropout voltage at full load and over-temperature makes it especially valuable in battery-powered systems and as high-efficiency noise filters in post-regulator applications. Unlike the older NPN-pass transistor designs, where the minimum dropout voltage is limited by the base-to-emitter voltage drop and collector-to-emitter saturation voltage, the dropout performance of the PNP output of these devices is limited only by the low VCE saturation voltage.

The MIC39100/1/2 regulator is fully protected from damage due to fault conditions. The linear current limiting is provided. The output current during the overload conditions is constant. The thermal shutdown disables the device when the die temperature exceeds the maximum safe operating temperature. The transient protection allows device (and load) survival even when the input voltage spikes above and below the nominal. The output structure of these regulators allows voltages in excess of the desired output voltage to be applied without reverse current flow.

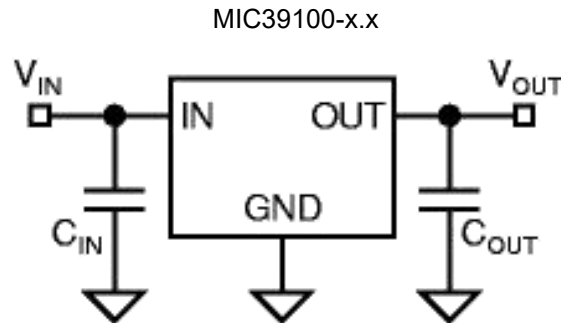


Fig.5. Capacitor requirements

Output Capacitor

The MIC39100/1/2 requires an output capacitor to maintain stability and improve transient response. Proper selection of a capacitor is important to ensure proper operation.

Selection of the MIC39100/1/2 output capacitor is dependent upon the ESR (equivalent series resistance) of the output capacitor to maintain the stability.

When the output capacitor is 10 μ F or greater, the output capacitor should have an ESR less than 2 Ω . This will improve the transient response and promote the stability. Ultra-low ESR capacitors (<100m Ω), such as ceramic chip capacitors, may promote the instability. These very low ESR levels may cause an oscillation and/or underdamped transient response. A low ESR solid tantalum capacitor works extremely well and provides a good transient response and the stability over the temperature range. Aluminum electrolytes can also be used, as long as the capacitor ESR is <2 Ω .

The value of the output capacitor can be increased without limit. Higher capacitance values help one to improve transient response and ripple rejection and reduce an output noise.

Input Capacitor

An input capacitor of 1 μ F or greater is recommended when the device is more than 10 cm away from the bulk AC supply capacitance, or when the supply is a battery. Small, surface-mounted, ceramic chip capacitors can be used for the bypassing. Larger values will help one to improve the ripple rejection by bypassing the input to the regulator, further improving the integrity of the output voltage.

Error Flag

The MIC39101 features an Error Flag (FLG), which monitors the output voltage and signals an error condition when this voltage drops 5% below its expected value. The Error Flag is an open-collector output that pulls low under fault conditions and may sink up to 10mA. A low output voltage signifies a number of possible problems, including an overcurrent fault (the device is in current limit) or low input voltage. The FLG output is inoperative in over-temperature conditions. A pull-up resistor from FLG to either VIN or VOUT is required for proper operation. For the information regarding the minimum and maximum values of pull-up resistance, refer to the graph in the typical characteristics section of the data sheet.

Enable Input

The MIC39101 and MIC39102 versions feature an active High enable (EN) input that allows on-off control of the regulator. The current drain reduces to "zero" when the device is shut down, with only microamperes of leakage current. The EN input has TTL/CMOS compatible thresholds for simple logic interfacing. EN may be directly tied to VIN and pulled up to the maximum supply voltage.

Transient Response and 3.3V to 2.5V or 2.5V to 1.8V Conversion

The MIC39100/1/2 has an excellent transient response to variations in the input voltage and load current. The device has been designed to respond quickly to the load current and input voltage variations. Large output capacitors are not required to obtain this performance. A standard 10 F output capacitor, preferably tantalum, is all that is required. Larger values help one to improve performance even further.

By virtue of its low-dropout voltage, this device does not saturate into dropout as readily as similar NPN-based designs. When converting 3.3V to 2.5V or 2.5V to 1.8V, the NPN-based regulators are already operating in the dropout, with typical dropout requirements of 1.2V or greater. To convert down to 2.5V or 1.8V without operating in the dropout, NPN-based regulators require an input voltage of 3.7V at the very least.

The MIC39100 regulator will provide an excellent performance with an input as low as 3.0V or 2.5V, respectively. This gives the PNP-based regulators a distinct advantage over the older, NPN-based linear regulators.

Minimum Load Current

The MIC39100/1/2 regulator is specified between finite loads. If the output current is too small, leakage currents dominate and the output voltage rises. A 10mA minimum load current is necessary for proper regulation.

Adjustable Regulator Design

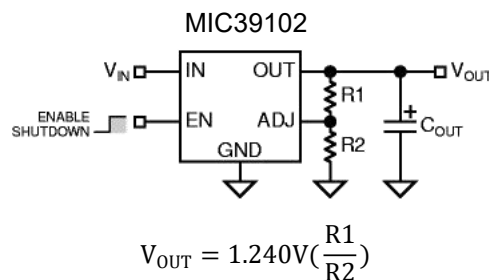


Fig.6. The adjustable regulator with resistors

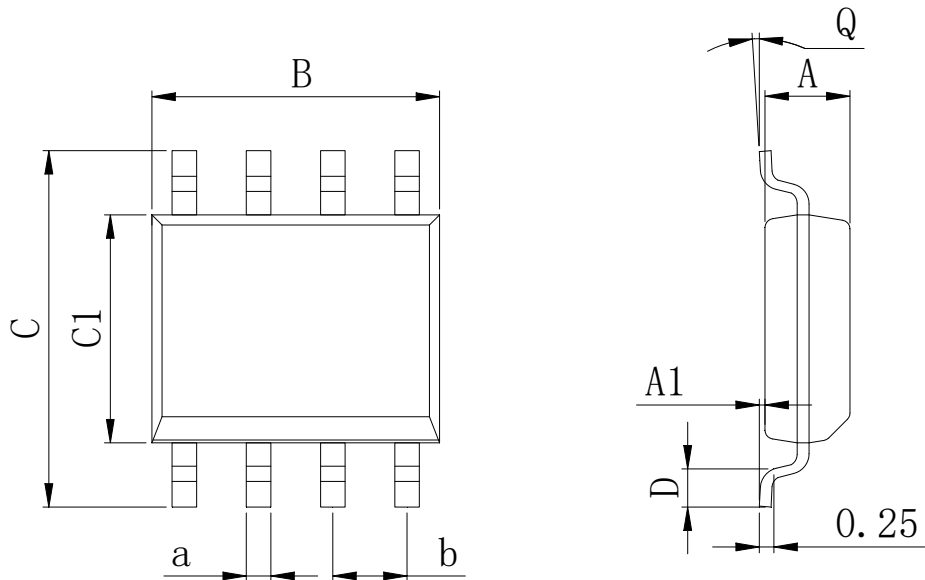
The MIC39102 allows programming the output voltage anywhere between 1.24V and 16V (the maximum operating rating of the family). Two resistors are used. The resistor values are calculated by:

$$R1 = R2 \left(\frac{V_{OUT}}{1.240} - 1 \right)$$

where V_{OUT} is the desired output voltage. Fig.6 shows the component definition. Applications with widely varying load currents may scale the resistors to draw the minimum load current required for proper operation (see above).

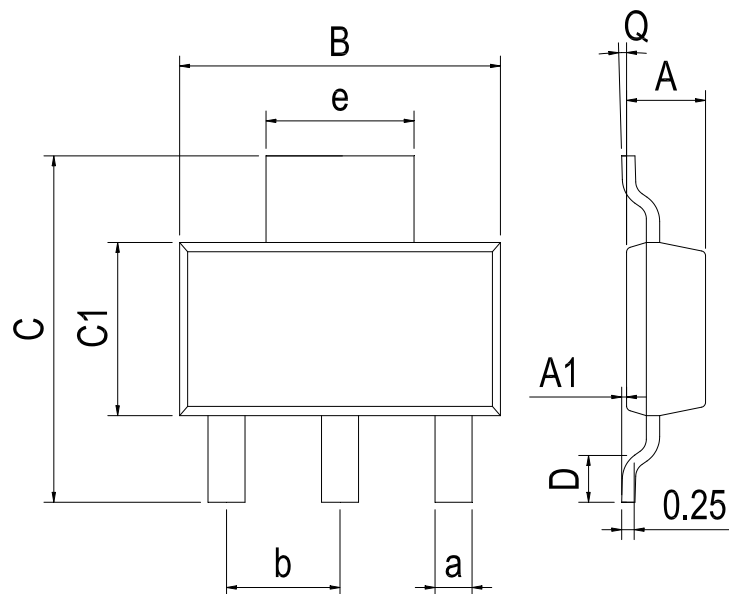
Physical Dimensions

SOP8


Dimensions In Millimeters(SOP8)

Symbol:	A	A1	B	C	C1	D	Q	a	b
Min:	1.35	0.05	4.90	5.80	3.80	0.40	0°	0.35	1.27 BSC
Max:	1.55	0.20	5.10	6.20	4.00	0.80	8°	0.45	

SOT223


Dimensions In Millimeters(SOT223)

Symbol:	A	A1	B	C	C1	D	Q	a	b	e
Min:	1.50	0.05	6.30	6.70	3.30	0.65	0°	0.66	2.30 BSC	3.00 BSC
Max:	1.70	0.20	6.70	7.30	3.70	1.10	8°	0.84		

IMPORTANT STATEMENT:

Huaguan Semiconductor reserves the right to change its products and services without notice. Before ordering, the customer shall obtain the latest relevant information and verify whether the information is up to date and complete. Huaguan Semiconductor does not assume any responsibility or obligation for the altered documents.

Customers are responsible for complying with safety standards and taking safety measures when using Huaguan Semiconductor products for system design and machine manufacturing. You will bear all the following responsibilities: select the appropriate Huaguan Semiconductor products for your application; Design, validate and test your application; Ensure that your application meets the appropriate standards and any other safety, security or other requirements. To avoid the occurrence of potential risks that may lead to personal injury or property loss.

Huaguan Semiconductor products have not been approved for applications in life support, military, aerospace and other fields, and Huaguan Semiconductor will not bear the consequences caused by the application of products in these fields.

The technical and reliability data (including data sheets), design resources (including reference designs), application or other design suggestions, network tools, safety information and other resources provided for the performance of semiconductor products produced by Huaguan Semiconductor are not guaranteed to be free from defects and no warranty, express or implied, is made. The use of testing and other quality control technologies is limited to the quality assurance scope of Huaguan Semiconductor. Not all parameters of each device need to be tested.

The documentation of Huaguan Semiconductor authorizes you to use these resources only for developing the application of the product described in this document. You have no right to use any other Huaguan Semiconductor intellectual property rights or any third party intellectual property rights. It is strictly forbidden to make other copies or displays of these resources. You should fully compensate Huaguan Semiconductor and its agents for any claims, damages, costs, losses and debts caused by the use of these resources. Huaguan Semiconductor accepts no liability for any loss or damage caused by infringement.

X-ON Electronics

Largest Supplier of Electrical and Electronic Components

Click to view similar products for [Linear Voltage Regulators](#) category:

Click to view products by [HGSEMI](#) manufacturer:

Other Similar products are found below :

[LV5684PVD-XH](#) [MCDTSA6-2R](#) [L7815ACV-DG](#) [LV56801P-E](#) [UA7805CKC](#) [714954EB](#) [ZMR500QFTA](#) [BA033LBSG2-TR](#)
[NCV78M05ABDTRKG](#) [LV5680P-E](#) [L79M05T-E](#) [L78LR05D-MA-E](#) [NCV317MBTG](#) [NTE7227](#) [MP2018GZD-33-P](#) [MP2018GZD-5-P](#)
[LV5680NPVC-XH](#) [ZTS6538SE](#) [UA78L09CLP](#) [UA78L09CLPR](#) [CAT6221-PPTD-GT3](#) [MC78M09CDTRK](#) [NCV51190MNTAG](#)
[BL1118CS8TR1833](#) [BL8563CKETR18](#) [BL8077CKETR33](#) [BL9153-33CC3TR](#) [BL9161G-15BADRN](#) [BL9161G-28BADRN](#)
[BRCO7530MMC](#) [CJ7815B-TFN-ARG](#) [LM317C](#) [GM7333K](#) [GM7350K](#) [XC6206P332MR](#) [HT7533](#) [LM7912S/TR](#) [LT1764S/TR](#) [LM7805T](#)
[LM338T](#) [LM1117IMP-3.3/TR](#) [HT1117AM-3.3](#) [HT7550S](#) [AMS1117-3.3](#) [HT7150S](#) [78L12](#) [HT7550](#) [HT7533-1](#) [HXY6206I-2.5](#) [HT7133](#)