

# Very low offset single bipolar operational amplifier

## Features

- Extremely low offset: 150 $\mu$ V/ max.
- Low input bias current: 1.8nA
- LOW  $V_{i0}$  drift: 0.5 $\mu$ V/ $^{\circ}$ C
- Ultra stable with time: 2 $\mu$ V/month max.
- Wide supply voltage range:  $\pm$ 3V to  $\pm$  22V
- Temperature range: 0 $^{\circ}$ C to -105 $^{\circ}$ C

## Description

The OP07 is a very high precision op-amp with an offset voltage maximum of 150 $\mu$ V.

Offering also low input current (1.8nA) and high gain (400V/mV), the OP07 is particularly suitable for instrumentation applications.

## ORDERING INFORMATION

DEVICE	Package Type	MARKING	Packing	Packing Qty
OP07CN	DIP8	OP07C	TUBE	2000/box
OP07DN	DIP8	OP07D	TUBE	2000/box
OP07CM/TR	SOP8	OP07C	REEL	2500/reel
OP07DM/TR	SOP8	OP07D	REEL	2500/reel

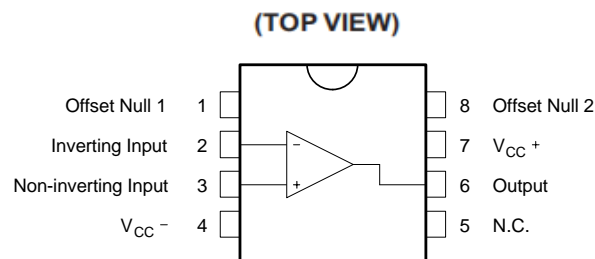

# 1 Schematic diagram

Figure 1. Schematic diagram

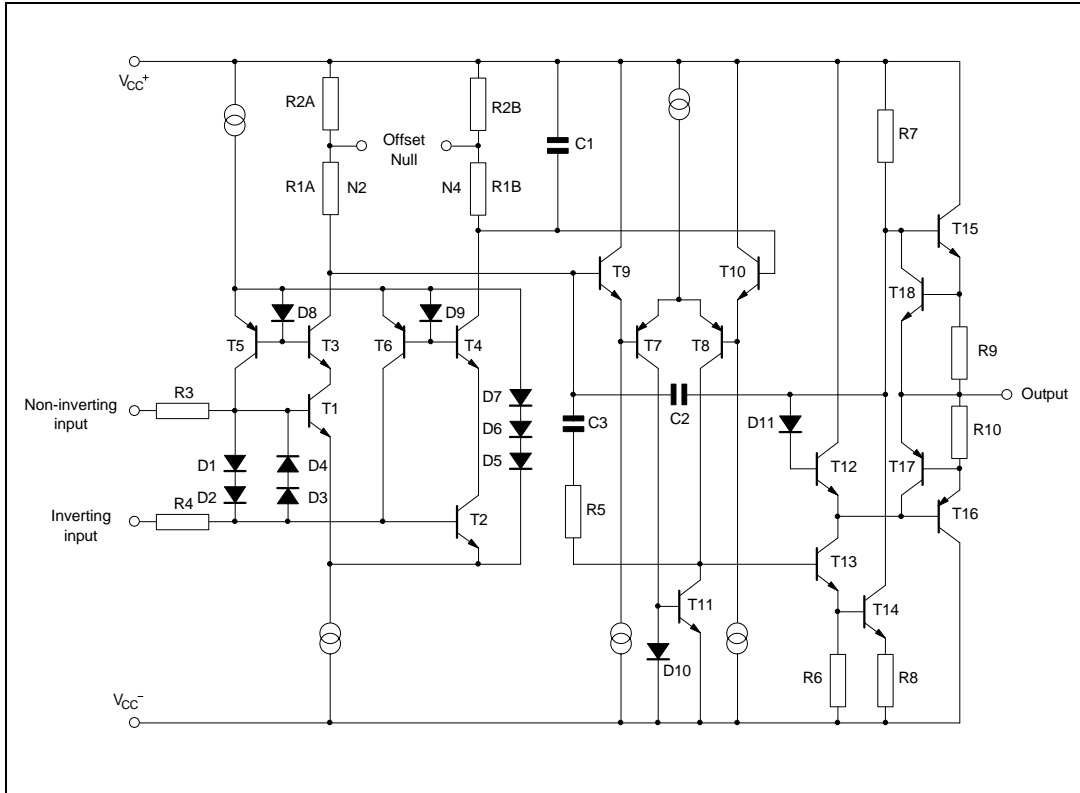
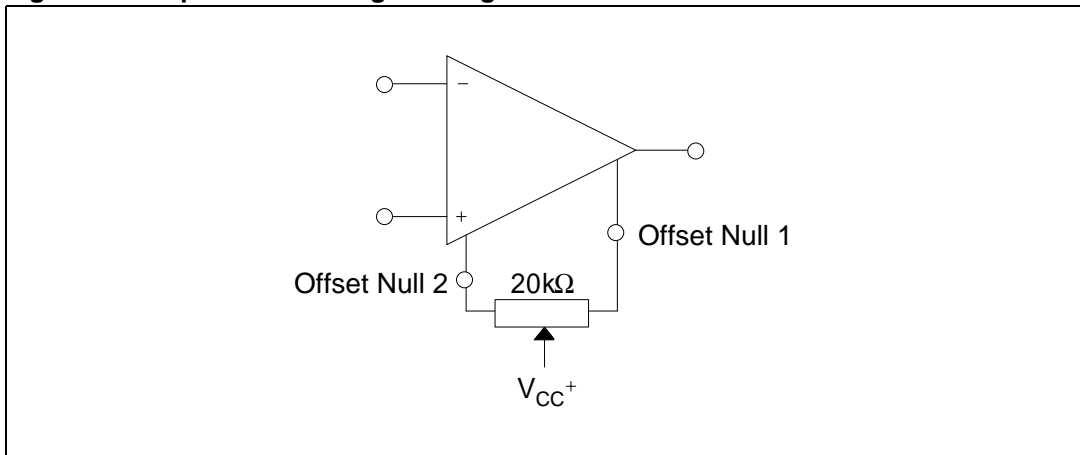

Figure 2. Input offset voltage nulling circuit



## 2 Absolute maximum ratings

**Table 1. Absolute maximum ratings**

Symbol	Parameter	Value	Unit
$V_{CC}$	Supply voltage	$\pm 22$	V
$V_{id}$	Differential input voltage	$\pm 30$	V
$V_i$	Input voltage	$\pm 22$	V
$T_{oper}$	Operating temperature	-40 to 85	°C
$T_{stg}$	Storage temperature	-65 to 150	°C
$R_{thja}$	Thermal resistance junction to ambient <sup>(1) (2)</sup> DIP8	85	°C/W
$R_{thjc}$	Thermal resistance junction to case <sup>(1) (2)</sup> DIP8	41	°C/W
ESD	HBM: human body model <sup>(3)</sup>	1.5	kV
	MM: machine model <sup>(4)</sup>	200	V
	CDM: charged device model <sup>(5)</sup>	1.5	kV

1. Short-circuits can cause excessive heating and destructive dissipation.
2.  $R_{th}$  are typical values.
3. Human body model: 100pF discharged through a 1.5k $\Omega$  resistor between two pins of the device, done for all couples of pin combinations with other pins floating.
4. Machine model: a 200pF cap is charged to the specified voltage, then discharged directly between two pins of the device with no external series resistor (internal resistor < 5 $\Omega$ ). Done for all couples of pin combinations with other pins floating.
5. Charged device model: all pins plus package are charged together to the specified voltage and then discharged directly to the ground.

### 3 Electrical characteristics

**Table 2.**  $V_{CC^+} = 15\text{ V}$ ,  $V_{CC^-} = \text{Ground}$ ,  $T_{amb} = 25^\circ\text{ C}$  (unless otherwise specified)

Symbol	Parameter	OP07C			OP07D			Unit
		Min.	Typ.	Max.	Min.	Typ.	Max.	
$V_{io}$	Input offset voltage $0^\circ\text{C} \leq T_{amb} \leq +105^\circ\text{C}$		60 85				150 250	$\mu\text{V}$
	Long term input offset - voltage stability <sup>(1)</sup>		0.4					$\mu\text{V}/\text{Mo}$
$DV_{io}$	Input offset voltage drift		0.5				2.5	$\mu\text{V}/^\circ\text{C}$
$I_{io}$	Input offset current ( $V_{ic} = 0\text{V}$ ) $0^\circ\text{C} \leq T_{amb} \leq +105^\circ\text{C}$		0.8	6 7		0.8	6 7	nA
	$DI_{io}$	Input offset current drift		15	50		15	50
$DI_{ib}$	Input bias current drift		15	50		15	50	$\text{pA}/^\circ\text{C}$
$R_o$	Open loop output resistance		60			60		$\Omega$
$R_{id}$	Differential input resistance		33			33		MW
$R_{ic}$	Common mode input resistance		120			120		GW
$V_{icm}$	Input common mode voltage range $0^\circ\text{C} \leq T_{amb} \leq +105^\circ\text{C}$	$\pm 13$ $\pm 13$	$\pm 13.5$		$\pm 13$ $\pm 13$	$\pm 13.5$		V
	$\text{CMR}$	Common-mode rejection ratio ( $V_{ic} = V_{icm - \text{min}}$ ) $0^\circ\text{C} \leq T_{amb} \leq +105^\circ\text{C}$	100 97	120		94 94	110 106	
$\text{SVR}$	Supply voltage rejection ratio ( $V_{CC} = \pm 3$ to $\pm 18\text{V}$ ) $0^\circ\text{C} \leq T_{amb} \leq +105^\circ\text{C}$	90 86	104		90 86	104		dB
	$A_{vd}$	Large signal voltage gain $V_{CC} = \pm 15$ , $R_L = 2\text{k}\Omega$ , $V_O = \pm 10\text{V}$ $0^\circ\text{C} \leq T_{amb} \leq +105^\circ\text{C}$	120 100	400		120 100	400	
$V_{CC} = \pm 3$ , $R_L = 500\Omega$ , $V_O = \pm 0.5\text{V}$		100	400		100	400		
$V_{opp}$		Output voltage swing $R_L = 10\text{k}\Omega$	$\pm 12$	$\pm 13$		$\pm 12$	$\pm 13$	
	$R_L = 2\text{k}\Omega$	$\pm 11.5$	$\pm 12.8$		$\pm 11.5$	$\pm 12.8$		
	$R_L = 1\text{k}\Omega$		$\pm 12$			$\pm 12$		
	$0^\circ\text{C} \leq T_{amb} \leq +105^\circ\text{C}$ , $R_L = 2\text{k}\Omega$	$\pm 11$			$\pm 11$			
$\text{SR}$	Slew rate ( $R = 2\text{k}\Omega$ , $C_L = 100\text{pF}$ )		0.17			0.17		V/us
$\text{GBP}$	Gain bandwidth product ( $R_L = 2\text{k}\Omega$ , $C_L = 100\text{pF}$ , $f = 100\text{kHz}$ )		0.5			0.5		MHz
$I_{CC}$	Supply current - no load $0^\circ\text{C} \leq T_{amb} \leq +105^\circ\text{C}$		2.7	5 6		2.7	5 6	mA
	$V_{CC} = \pm 3\text{V}$		0.67	1.3		0.67	1.3	
$e_n$	Equivalent input noise voltage $f = 10\text{Hz}$		11	20		11	20	$\frac{\text{nV}}{\sqrt{\text{Hz}}}$
	$f = 100\text{Hz}$		10.5	13.5		10.5	13.5	
	$f = 1\text{kHz}$		10	11.5		10	11.5	
$i_n$	Equivalent input noise current $f = 10\text{Hz}$		0.3	0.9		0.3	0.9	$\frac{\text{pA}}{\sqrt{\text{Hz}}}$
	$f = 100\text{Hz}$		0.2	0.3		0.2	0.3	
	$f = 1\text{kHz}$		0.1	0.2		0.1	0.2	

1. Long term input offset voltage stability refers to the average trend line of  $V_{io}$  vs time over extended periods after the first 30 days of operation.

PACKAGE

SOP8

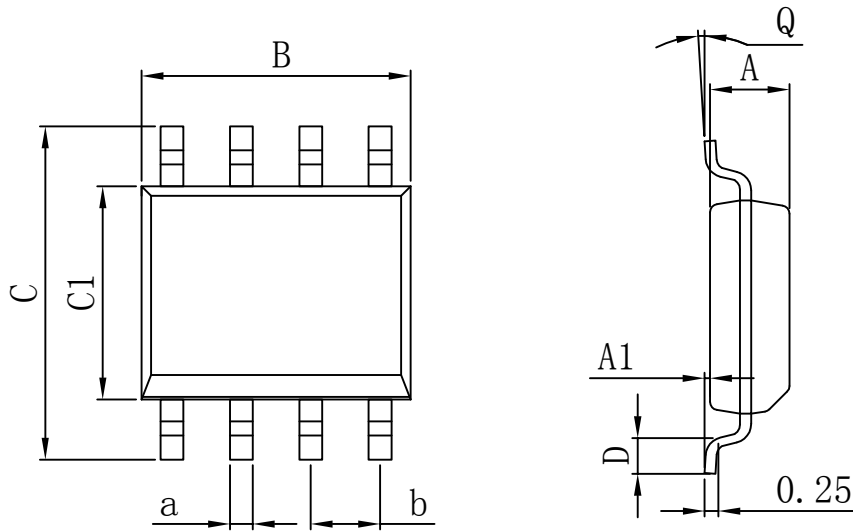

Dimensions In Millimeters					
Symbol :	Min :	Max :	Symbol :	Min :	Max :
A	1.225	1.570	D	0.400	0.950
A1	0.100	0.250	Q	0°	8°
B	4.800	5.100	a	0.420 TYP	
C	5.800	6.250	b	1.270 TYP	
C1	3.800	4.000			

DIP8

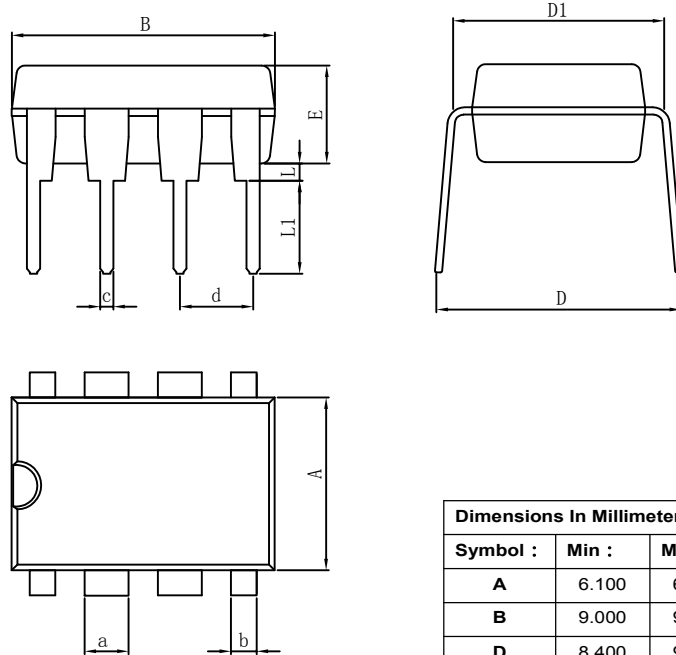

Dimensions In Millimeters					
Symbol :	Min :	Max :	Symbol :	Min :	Max :
A	6.100	6.680	L1	3.000	3.600
B	9.000	9.500	a	1.524 TYP	
D	8.400	9.000	b	0.889 TYP	
D1	7.420	7.820	c	0.457 TYP	
E	3.100	3.550	d	2.540 TYP	
L	0.500	0.700			

Important statement:

Huaguan Semiconductor Co,Ltd. reserves the right to change the products and services provided without notice. Customers should obtain the latest relevant information before ordering, and verify the timeliness and accuracy of this information.

Customers are responsible for complying with safety standards and taking safety measures when using our products for system design and machine manufacturing to avoid potential risks that may result in personal injury or property damage.

Our products are not licensed for applications in life support, military, aerospace, etc., so we do not bear the consequences of the application of these products in these fields.

Our documentation is only permitted to be copied without any tampering with the content, so we do not accept any responsibility or liability for the altered documents.

## X-ON Electronics

Largest Supplier of Electrical and Electronic Components

*Click to view similar products for [Operational Amplifiers - Op Amps](#) category:*

*Click to view products by [HGSEMI](#) manufacturer:*

Other Similar products are found below :

[430227FB](#) [AZV831KTR-G1](#) [UPC451G2-A](#) [UPC824G2-A](#) [LT1678IS8](#) [042225DB](#) [058184EB](#) [UPC822G2-A](#) [UPC258G2-A](#)  
[NCS5651MNTXG](#) [NCV33202DMR2G](#) [NJM324E](#) [NTE925](#) [5962-9080901MCA\\*](#) [AP4310AUMTR-AG1](#) [HA1630D02MMEL-E](#)  
[HA1630S01LPEL-E](#) [SCY33178DR2G](#) [NJU77806F3-TE1](#) [NCV5652MUTWG](#) [NCV20034DR2G](#) [LM2902EDR2G](#) [NTE778S](#) [NTE871](#)  
[NTE924](#) [NTE937](#) [MCP6V16UT-E/OT](#) [MCP6V17T-E/MS](#) [MCP6V19T-E/ST](#) [SCY6358ADR2G](#) [LTC2065IUD#PBF](#) [NCS20282FCTTAG](#)  
[LM4565FVT-GE2](#) [EL5420CRZ-T7A](#) [TSV791IYLT](#) [TSV772IQ2T](#) [TLV2772QPWR](#) [NJM2100M-TE1](#) [NJM4556AM-TE1](#) [AS324MTR-E1](#)  
[AS358MMTR-G1](#) [MCP6232T-EMNY](#) [MCP662-E/MF](#) [TLC081AIP](#) [TLC082AIP](#) [TLE2074ACDW](#) [TLV07IDR](#) [TLV2170IDGKT](#)  
[TLV2455IDR](#) [TLV2461IDR](#)