

4.5MHz Zero-Drift CMOS Rail-to-Rail IO Opamp with RF Filter

Features

- Single-Supply Operation from +1.8V ~ +5.5V
- Rail-to-Rail Input / Output
- Gain-Bandwidth Product: 4.5MHz (Typ@25°C)
- Low Input Bias Current: 20pA (Typ@25°C)
- Low Offset Voltage: 30μV (Max @25°C)
- Quiescent Current: 550μA per Amplifier (Typ)
- Operating Temperature: -45°C ~ +125°C
- Zero Drift: 0.01μV/°C (Typ)
- Embedded RF Anti-EMI Filter
- Small Package:
 - OPA340 Available in SOT23-5 and SOP-8 Packages
 - OPA2340 Available in MSOP-8 and SOP-8 Packages
 - OPA4340 Available in SOP-14 and TSSOP-14 Packages

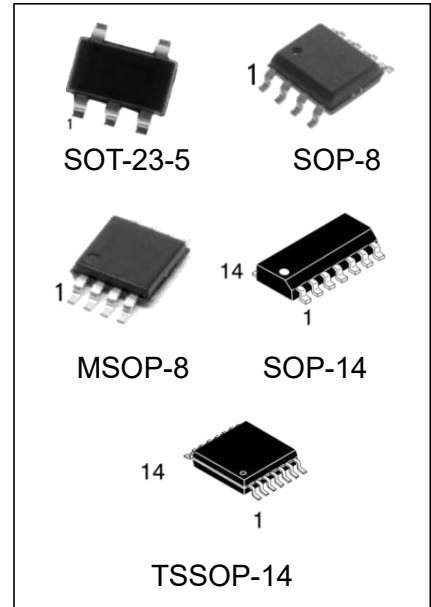

Ordering Information

DEVICE	Package Type	MARKING	Packing	Packing Qty
OPA340M5/TR	SOT-23-5	A340	REEL	3000pcs/reel
OPA340M/TR	SOP-8	A340	REEL	2500pcs/reel
OPA2340M/TR	SOP-8	OPA2340,A2340	REEL	2500pcs/reel
OPA2340MM/TR	MSOP-8	A2340	REEL	3000pcs/reel
OPA4340M/TR	SOP-14	OPA4340	REEL	2500pcs/reel
OPA4340MT/TR	TSSOP-14	OPA4340,A4340	REEL	2500pcs/reel

General Description

The OPAx340 amplifier is single/dual/quad supply, micro-power, zero-drift CMOS operational amplifiers, the amplifiers offer bandwidth of 4.5MHz, rail-to-rail inputs and outputs, and single-supply operation from 1.8V to 5.5V. OPAx340 uses chopper stabilized technique to provide very low offset voltage (less than 30 μ V maximum) and near zero drift over temperature. Low quiescent supply current of 550 μ A per amplifier and very low input bias current of 20pA make the devices an ideal choice for low offset, low power consumption and high impedance applications. The OPAx340 offers excellent CMRR without the crossover associated with traditional complementary input stages. This design results in superior performance for driving analog-to-digital converters (ADCs) without degradation of differential linearity.

The OPA340 is available in SOT23-5 and SOP-8 packages. And the OPA2340 is available in MSOP-8 and SOP-8 packages. The OPA4340 Quad is available in Green SOP-14 and TSSOP-14 packages. The extended temperature range of -45°C to +125°C over all supply voltages offers additional design flexibility.

Applications

- Transducer Application
- Temperature Measurements
- Electronics Scales
- Handheld Test Equipment
- Battery-Powered Instrumentation

Pin Configuration

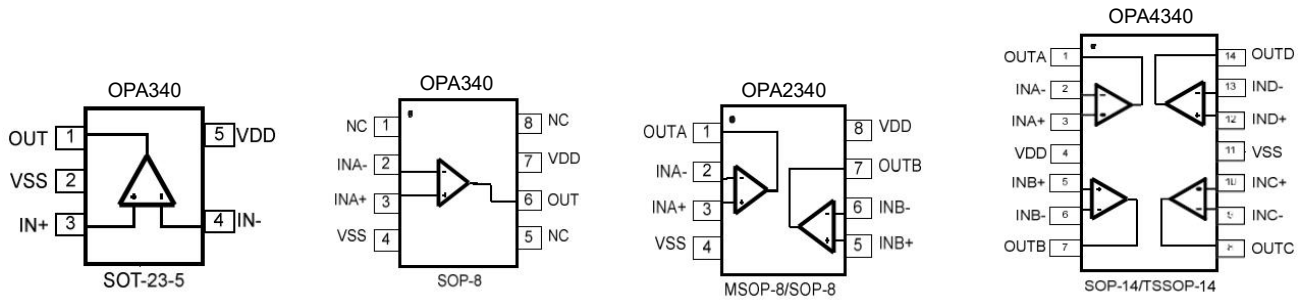

Figure 1. Pin Assignment Diagram

Absolute Maximum Ratings

Condition	Min	Max
Power Supply Voltage (VDD to Vss)	-0.5V	+7.5V
Analog Input Voltage (IN+ or IN-)	Vss-0.5V	VDD+0.5V
PDB Input Voltage	Vss-0.5V	+7V
Operating Temperature Range	-45°C	+125°C
Junction Temperature, 10s	-	+160°C
Storage Temperature Range	-55°C	+150°C
Lead Temperature (soldering, 10sec)	-	+245°C
Package Thermal Resistance (TA=+25°C)	SOP-8, θ_{JA}	125°C/W
	MSOP-8, θ_{JA}	216°C/W
	SOT23-5, θ_{JA}	190°C/W
ESD Susceptibility	HBM	6KV
	MM	400V

Note: Stress greater than those listed under Absolute Maximum Ratings may cause permanent damage to the device. This is a stress rating only and functional operation of the device at these or any other conditions outside those indicated in the operational sections of this specification are not implied. Exposure to absolute maximum rating conditions for extended periods may affect reliability.

Electrical Characteristics

(VS = +5V, VCM = +2.5V, VO = +2.5V, TA = +25°C, unless otherwise noted.)

PARAMETER	CONDITIONS	MIN	TYP	MAX	UNITS
INPUT CHARACTERISTICS					
Input Offset Voltage (VOS)			1	30	μV
Input Bias Current (IB)			20		pA
Input Offset Current (IOS)			10		pA
Common-Mode Rejection Ratio (CMRR)	VCM = 0V to 5V		110		dB
Large Signal Voltage Gain (AVO)	RL = 10kΩ, VO = 0.3V to 4.7V		145		dB
Input Offset Voltage Drift (ΔVOS/ΔT)			10	50	nV/°C
OUTPUT CHARACTERISTICS					
Output Voltage High (VOH)	RL = 100kΩ to -VS		4.998		V
	RL = 10kΩ to -VS		4.994		V
Output Voltage Low (VOL)	RL = 100kΩ to +VS		2		mV
	RL = 10kΩ to +VS		5		mV
Short Circuit Limit (ISC)	RL = 10Ω to -VS		43		mA
Output Current (IO)			30		mA
POWER SUPPLY					
Power Supply Rejection Ratio (PSRR)	VS = 2.5V to 5.5V		115		dB
Quiescent Current (IQ)	VO = 0V, RL = 0Ω		550		μA
DYNAMIC PERFORMANCE					
Gain-Bandwidth Product (GBP)	G = +100		4.5		MHz
Slew Rate (SR)	RL = 10kΩ		2.5		V/μs
Overload Recovery Time			0.10		ms
NOISE PERFORMANCE					
Voltage Noise (en p-p)	0Hz to 10Hz		0.2		μVP-P
Voltage Noise Density (en)	f = 1kHz		30		nV/√Hz

Typical Performance characteristics

Large Signal Transient Response at +5V

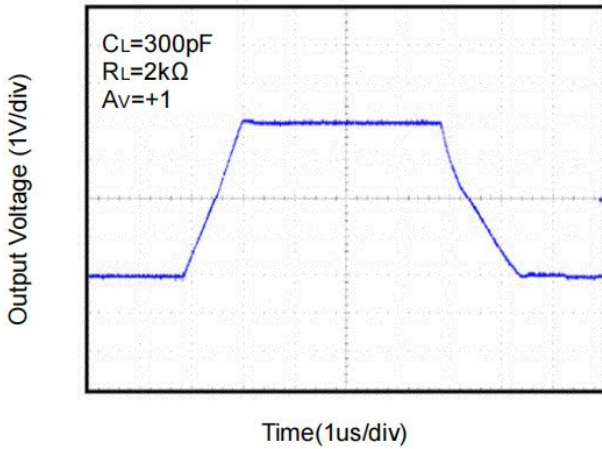

Large Signal Transient Response at +2.5V

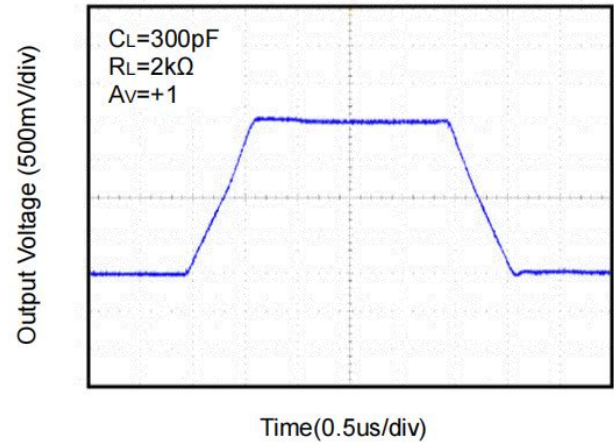

Small Signal Transient Response at +5V

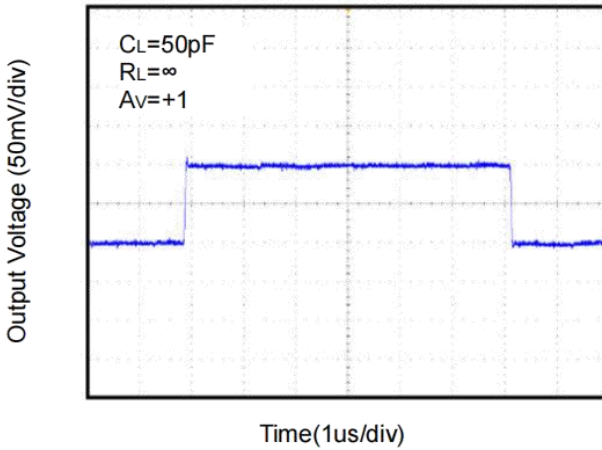

Small Signal Transient Response at +2.5V

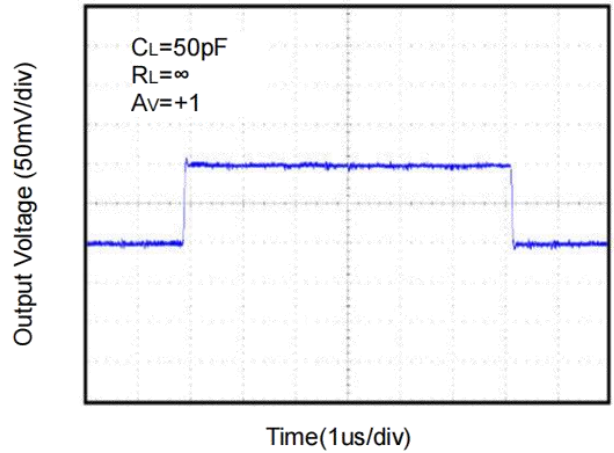

Closed Loop Gain vs. Frequency at +5V

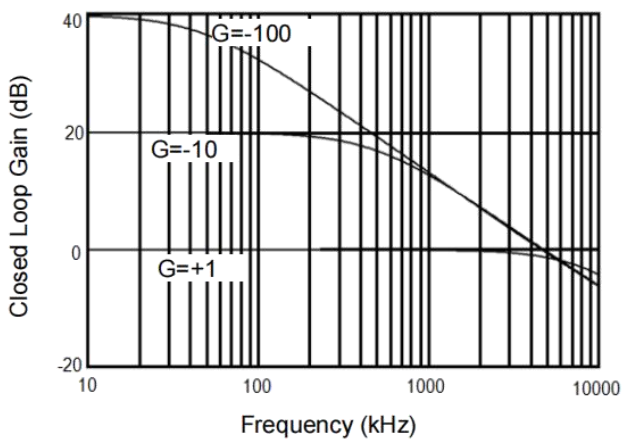

Closed Loop Gain vs. Frequency at +2.5V

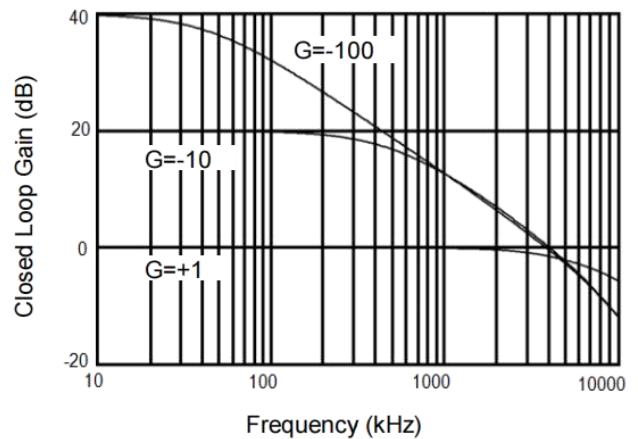

Typical Performance characteristics

Open Loop Gain, Phase Shift vs. Frequency at +5V

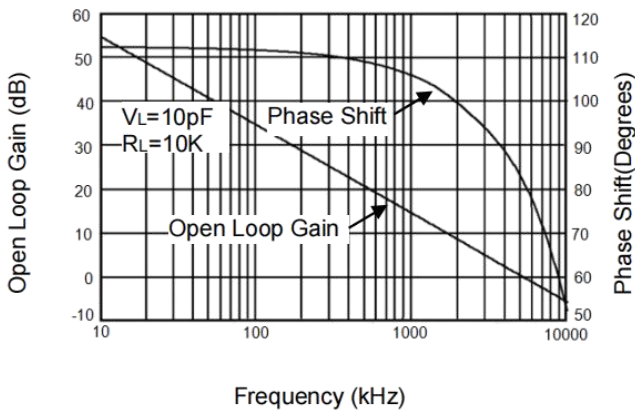

Open Loop Gain, Phase Shift vs. Frequency at +2.5V

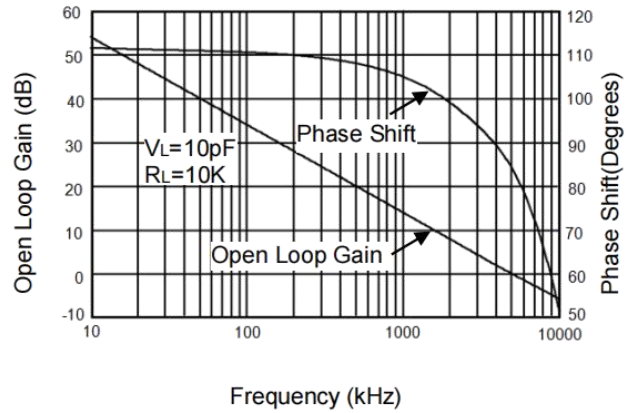

Positive Overvoltage Recovery

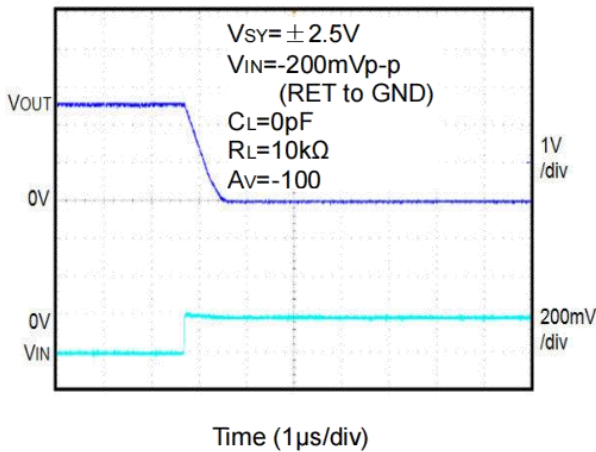

Negative Overvoltage Recovery

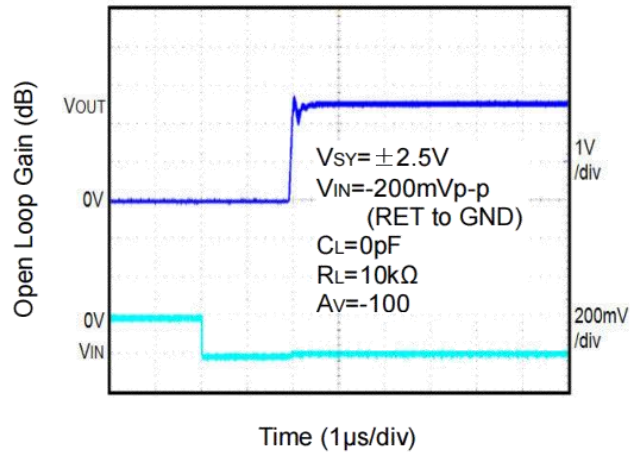

0.1Hz to 10Hz Noise at +5V

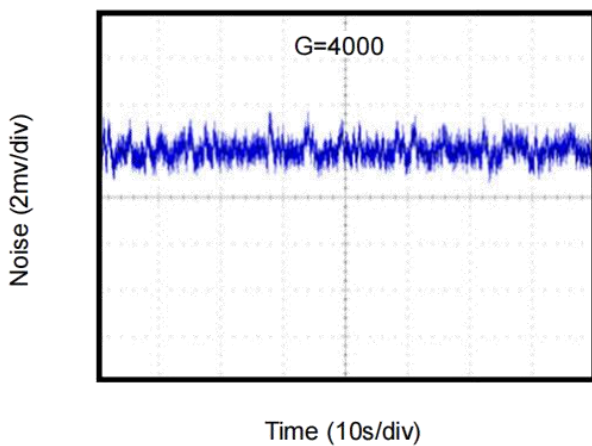

0.1Hz to 10Hz Noise at +2.5V

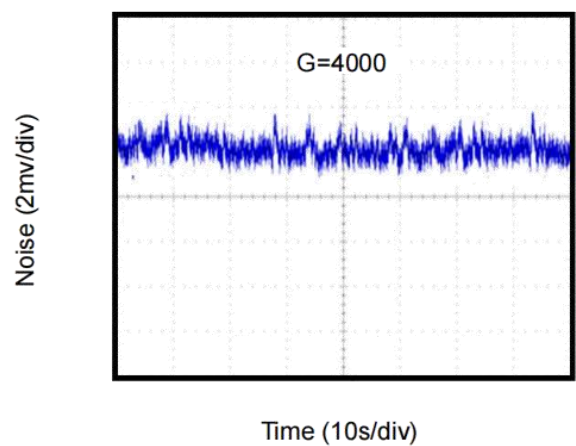

Application Note

Size

OPAx340 series op amps are unity-gain stable and suitable for a wide range of general-purpose applications. The small footprints of the OPAx340 series packages save space on printed circuit boards and enable the design of smaller electronic products.

Power Supply Bypassing and Board Layout

OPAx340 series operates from a single 1.8V to 5.5V supply or dual $\pm 0.9V$ to $\pm 2.75V$ supplies. For best performance, a $0.1\mu F$ ceramic capacitor should be placed close to the VDD pin in single supply operation. For dual supply operation, both VDD and VSS supplies should be bypassed to ground with separate $0.1\mu F$ ceramic capacitors.

Low Supply Current

The low supply current (typical $550\mu A$ per channel) of OPAx340 series will help to maximize battery life. They are ideal for battery powered systems.

Operating Voltage

OPAx340 series operate under wide input supply voltage (1.8V to 5.5V). In addition, all temperature specifications apply from $-40^{\circ}C$ to $+125^{\circ}C$. Most behavior remains unchanged throughout the full operating voltage range. These guarantees ensure operation throughout the single Li-Ion battery lifetime.

Rail-to-Rail Input

The input common-mode range of OPAx340 series extends $100mV$ beyond the supply rails ($VSS-0.1V$ to $VDD+0.1V$). This is achieved by using complementary input stage. For normal operation, inputs should be limited to this range.

Rail-to-Rail Output

Rail-to-Rail output swing provides maximum possible dynamic range at the output. This is particularly important when operating in low supply voltages. The output voltage of OPAx340 series can typically swing to less than $5mV$ from supply rail in light resistive loads ($>100k\Omega$), and $60mV$ of supply rail in moderate resistive loads ($10k\Omega$).

Capacitive Load Tolerance

The OPAx340 family is optimized for bandwidth and speed, not for driving capacitive loads. Output capacitance will create a pole in the amplifier's feedback path, leading to excessive peaking and potential oscillation. If dealing with load capacitance is a requirement of the application, the two strategies to consider are (1) using a small resistor in series with the amplifier's output and the load capacitance and (2) reducing the bandwidth of the amplifier's feedback loop by increasing the overall noise gain. Figure 2. shows a unity gain follower using the series resistor strategy. The resistor isolates the output from the capacitance and, more importantly, creates a zero in the feedback path that compensates for the pole created by the output capacitance.

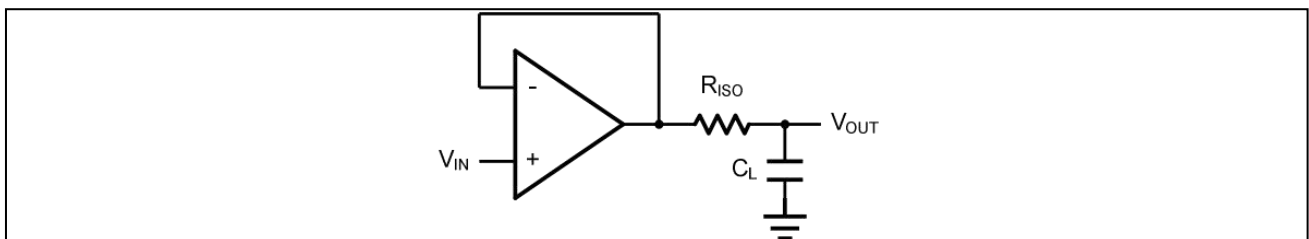

Figure 2. Indirectly Driving a Capacitive Load Using Isolation Resistor

The bigger the RISO resistor value, the more stable VOUT will be. However, if there is a resistive load RL in parallel with the capacitive load, a voltage divider (proportional to RISO/RL) is formed, this will result in a gain error.

The circuit in Figure 3 is an improvement to the one in Figure 2. RF provides the DC accuracy by feed-forward the VIN to RL. CF and RISO serve to counteract the loss of phase margin by feeding the high frequency component of the output signal back to the amplifier's inverting input, thereby preserving the phase margin in the overall feedback loop. Capacitive drive can be increased by increasing the value of CF. This in turn will slow down the pulse response.

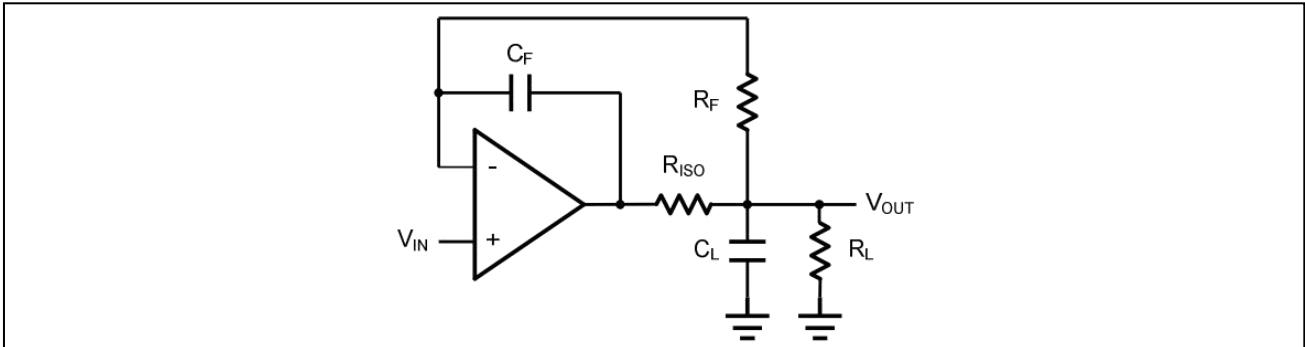

Figure 3. Indirectly Driving a Capacitive Load with DC Accuracy

Typical Application Circuits

Differential amplifier

The differential amplifier allows the subtraction of two input voltages or cancellation of a signal common the two inputs. It is useful as a computational amplifier in making a differential to single-end conversion or in rejecting a common mode signal. Figure 4.

shown the differential amplifier using OPAX340.

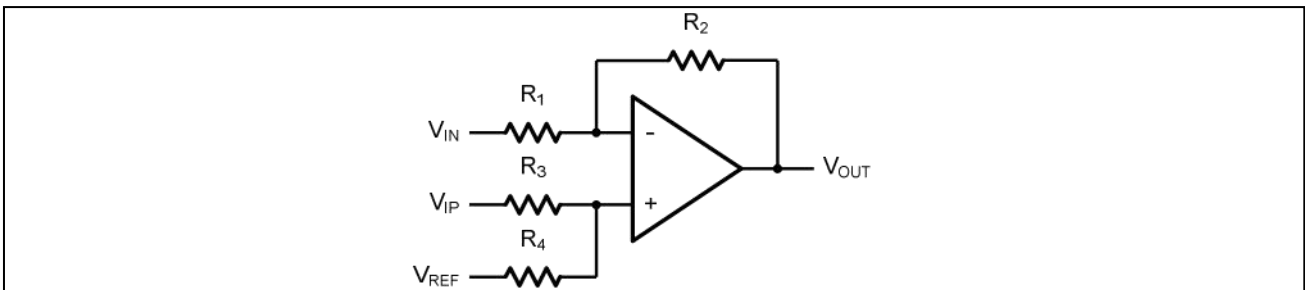

Figure 4. Differential Amplifier

$$V_{OUT} = \left(\frac{R_1 + R_2}{R_3 + R_4} \right) \frac{R_4}{R_1} V_{IN} - \frac{R_2}{R_1} V_{IP} + \left(\frac{R_1 + R_2}{R_3 + R_4} \right) \frac{R_3}{R_1} V_{REF}$$

If the resistor ratios are equal (i.e. R1=R3 and R2=R4), then

$$V_{OUT} = \frac{R_2}{R_1} (V_{IP} - V_{IN}) + V_{REF}$$

Low Pass Active Filter

The low pass active filter is shown in Figure 5. The DC gain is defined by $-R_2/R_1$. The filter has a -20dB/decade roll-off after its corner frequency $f_c = 1/(2\pi R_2 C_1)$.

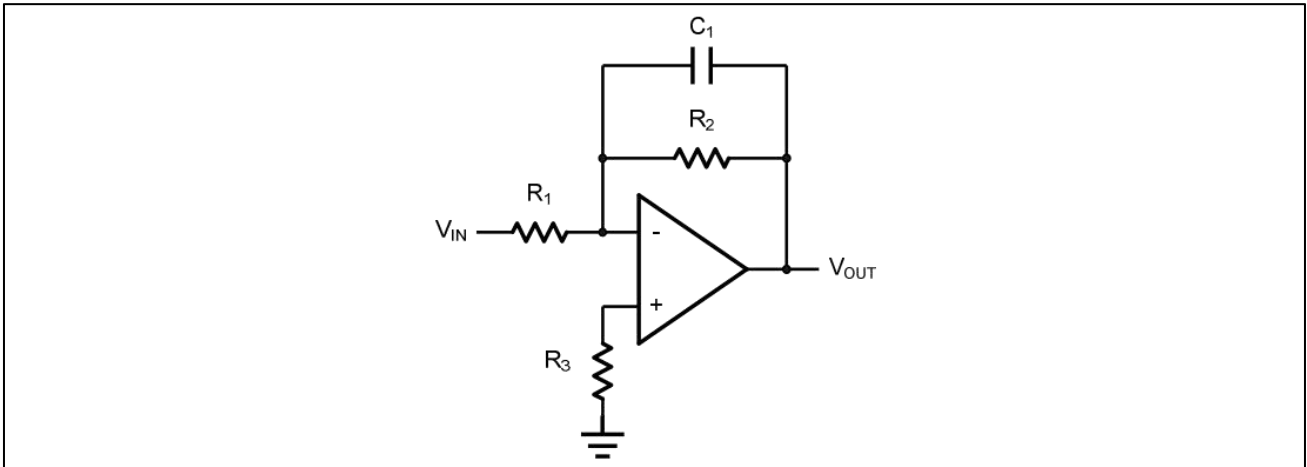

Figure 5. Low Pass Active Filter

Instrumentation Amplifier

The triple OPAx340 can be used to build a three-op-amp instrumentation amplifier as shown in Figure 6. The amplifier in Figure 6 is a high input impedance differential amplifier with gain of R_2/R_1 . The two differential voltage followers assure the high input impedance of the amplifier.

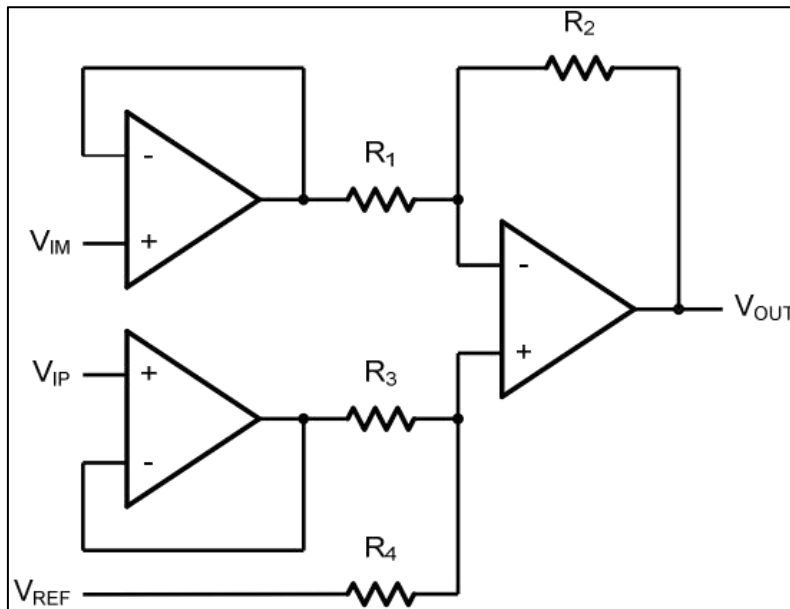
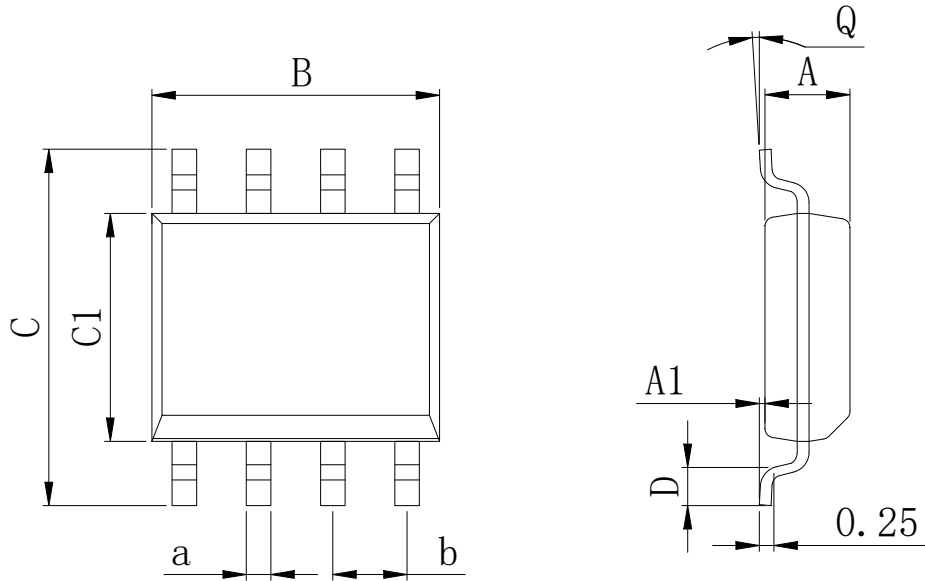

Figure 6. Instrument Amplifier

Physical Dimensions

SOP-8



Dimensions In Millimeters(SOP-8)									
Symbol:	A	A1	B	C	C1	D	Q	a	b
Min:	1.35	0.05	4.90	5.80	3.80	0.40	0°	0.35	1.27 BSC
Max:	1.55	0.20	5.10	6.20	4.00	0.80	8°	0.45	

MSOP-8

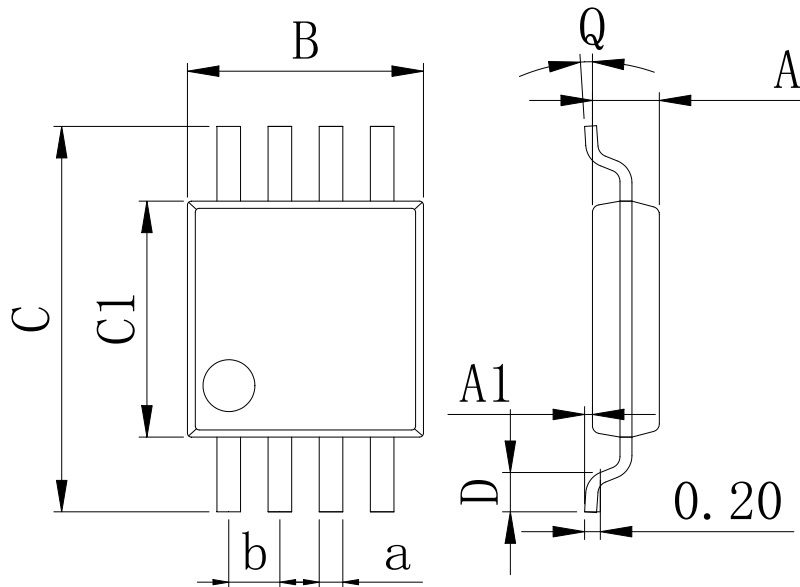

Dimensions In Millimeters(MSOP-8)									
Symbol:	A	A1	B	C	C1	D	Q	a	b
Min:	0.80	0.05	2.90	4.75	2.90	0.35	0°	0.25	0.65 BSC
Max:	0.90	0.20	3.10	5.05	3.10	0.75	8°	0.35	

Physical Dimensions

SOP-14

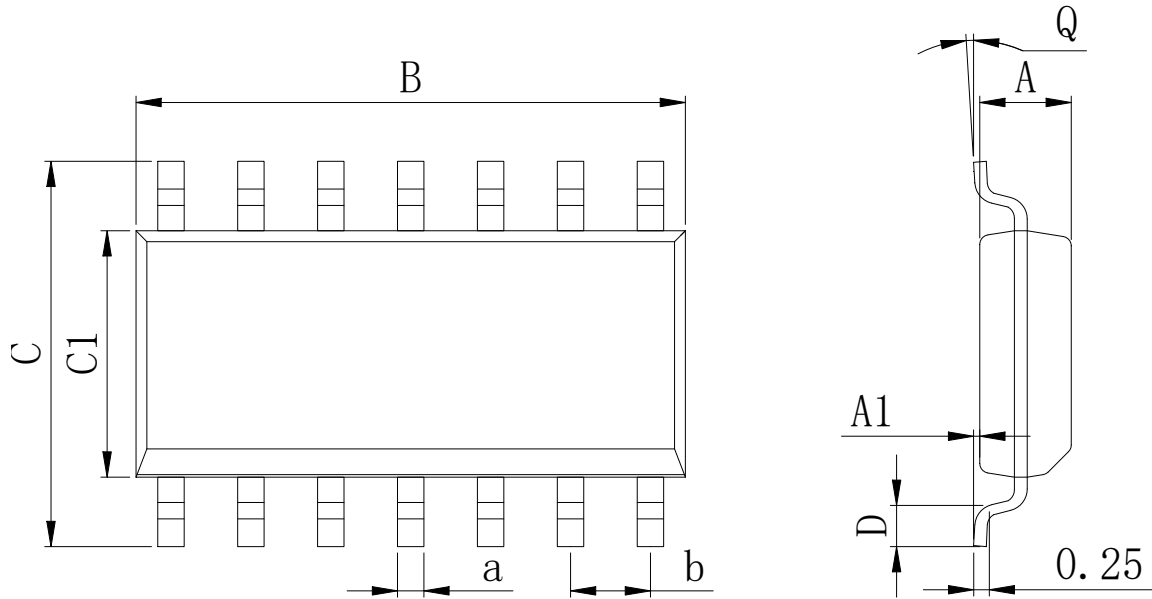
Dimensions In Millimeters(SOP-14)

Symbol:	A	A1	B	C	C1	D	Q	a	b
Min:	1.35	0.05	8.55	5.80	3.80	0.40	0°	0.35	1.27 BSC
Max:	1.55	0.20	8.75	6.20	4.00	0.80	8°	0.45	

TSSOP-14

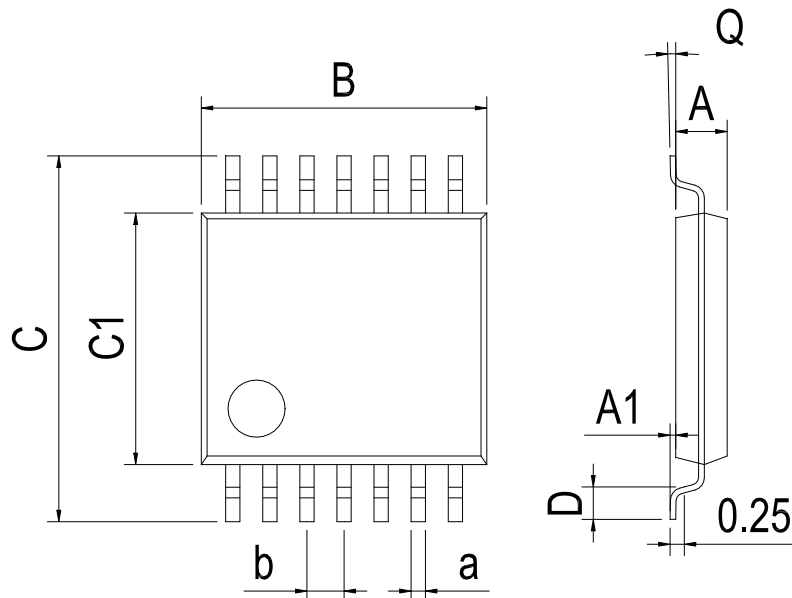
Dimensions In Millimeters(TSSOP-14)

Symbol:	A	A1	B	C	C1	D	Q	a	b
Min:	0.85	0.05	4.90	6.20	4.30	0.40	0°	0.20	0.65 BSC
Max:	0.95	0.20	5.10	6.60	4.50	0.80	8°	0.25	

Physical Dimensions

SOT-23-5

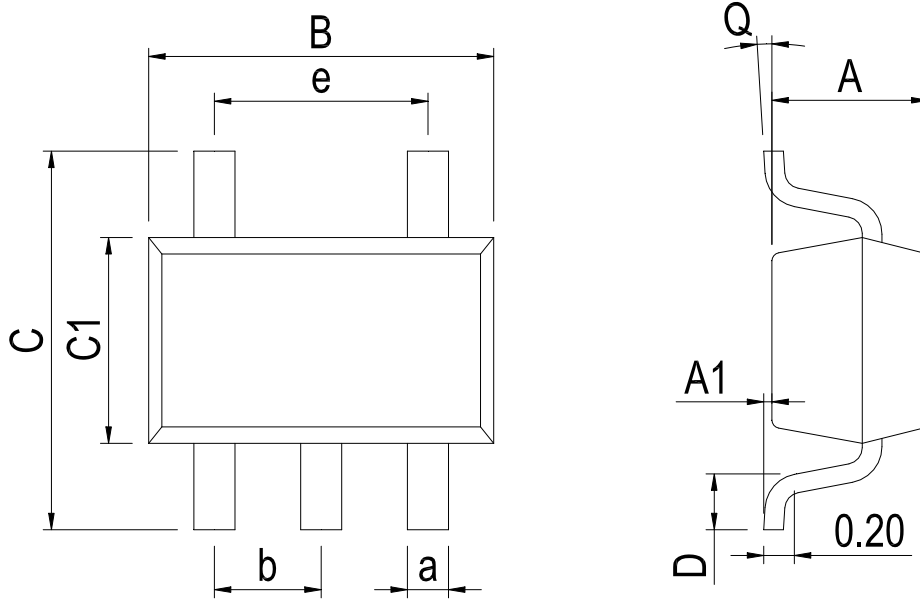

Dimensions In Millimeters(SOT-23-5)										
Symbol:	A	A1	B	C	C1	D	Q	a	b	e
Min:	1.05	0.00	2.82	2.65	1.50	0.30	0°	0.30	0.95 BSC	1.90 BSC
Max:	1.15	0.15	3.02	2.95	1.70	0.60	8°	0.40		

Revision History

DATE	REVISION	PAGE
2017-8-4	New	1-14
2023-7-24	Update encapsulation type、 Update Lead Temperature	1、 3

IMPORTANT STATEMENT:

Huaguan Semiconductor reserves the right to change its products and services without notice. Before ordering, the customer shall obtain the latest relevant information and verify whether the information is up to date and complete. Huaguan Semiconductor does not assume any responsibility or obligation for the altered documents.

Customers are responsible for complying with safety standards and taking safety measures when using Huaguan Semiconductor products for system design and machine manufacturing. You will bear all the following responsibilities: Select the appropriate Huaguan Semiconductor products for your application; Design, validate and test your application; Ensure that your application meets the appropriate standards and any other safety, security or other requirements. To avoid the occurrence of potential risks that may lead to personal injury or property loss.

Huaguan Semiconductor products have not been approved for applications in life support, military, aerospace and other fields, and Huaguan Semiconductor will not bear the consequences caused by the application of products in these fields. All problems, responsibilities and losses arising from the user's use beyond the applicable area of the product shall be borne by the user and have nothing to do with Huaguan Semiconductor, and the user shall not claim any compensation liability against Huaguan Semiconductor by the terms of this Agreement.

The technical and reliability data (including data sheets), design resources (including reference designs), application or other design suggestions, network tools, safety information and other resources provided for the performance of semiconductor products produced by Huaguan Semiconductor are not guaranteed to be free from defects and no warranty, express or implied, is made. The use of testing and other quality control technologies is limited to the quality assurance scope of Huaguan Semiconductor. Not all parameters of each device need to be tested.

The documentation of Huaguan Semiconductor authorizes you to use these resources only for developing the application of the product described in this document. You have no right to use any other Huaguan Semiconductor intellectual property rights or any third party intellectual property rights. It is strictly forbidden to make other copies or displays of these resources. You should fully compensate Huaguan Semiconductor and its agents for any claims, damages, costs, losses and debts caused by the use of these resources. Huaguan Semiconductor accepts no liability for any loss or damage caused by infringement.

X-ON Electronics

Largest Supplier of Electrical and Electronic Components

Click to view similar products for [Precision Amplifiers](#) category:

Click to view products by [HGSEMI](#) manufacturer:

Other Similar products are found below :

[LM201AN](#) [MCP6V52-E/MS](#) [ADA4692-4ARUZ-RL](#) [EL8176FSZ](#) [ISL28158FHZ-T7](#) [ISL28236FBZ](#) [ISL28236FBZ-T7](#) [ISL28258FUZ](#)
[ISL28258FUZ-T7](#) [ISL28276FBZ](#) [ISL28276IAZ](#) [ISL28276IAZ-T7](#) [ISL28288FUZ](#) [NCS21914DR2G](#) [NCS21914DTBR2G](#) [RS8654XP](#)
[AD8615AUJZ-REEL](#) [HG2376M/TR](#) [MS8362M](#) [LT1013IS8#TRPBF](#) [ADA4610-4ARZ-R7](#) [TP5591-TR](#) [AD8652ARZ-REEL](#) [AD8639ARZ-](#)
[REEL](#) [ADA4622-2ARZ-RL](#) [LTC6241HVCS8#TRPBF](#) [LT6011IS8#TRPBF](#) [LT6230IS6-10#TRPBF](#) [LT6011IMS8#TRPBF](#)
[LTC6246CS6#TRMPBF](#) [LT6230CS6#TRPBF](#) [LT6235IGN#TRPBF](#) [LTC6362IDD#TRPBF](#) [AD8625ARUZ-REEL](#) [LTC2050HVIS8#TRPBF](#)
[AD8627AKSZ-REEL](#) [LT6220IS5#TRPBF](#) [LT6236IS6#TRPBF](#) [OP213ESZ-REEL](#) [ADA4092-4ARUZ-RL](#) [CBM8532AMS8](#) [CBM8628AST5](#)
[CBM8534AS14](#) [CBM8608AS14](#) [CBM8534ATS14](#) [CBM8629AS8](#) [CBM8608ATS14](#) [CBM8606AS8](#) [COS8552WSRA](#) [COS8552WSRC](#)