

## 1MHz, 45 $\mu$ A, CMOS, Rail-to-Rail OPERATIONAL AMPLIFIERS

### FEATURES

- LOW IQ: 45 $\mu$ A typical
  - LOW COST
  - RAIL-TO-RAIL INPUT AND OUTPUT
  - SINGLE SUPPLY: +2.1V to +5.5V
  - INPUT BIAS CURRENT: 0.5pA
  - HIGH SPEED: POWER WITH BANDWIDTH: 1MHz
  - SMALL PACKAGE:
- OPA348 Available in SOT23-5 、 SC70-5 and SOP-8 Packages  
 OPA2348 Available in MSOP-8 and SOP-8 Packages  
 OPA4348 Available in SOP-14 and TSSOP-14 Packages

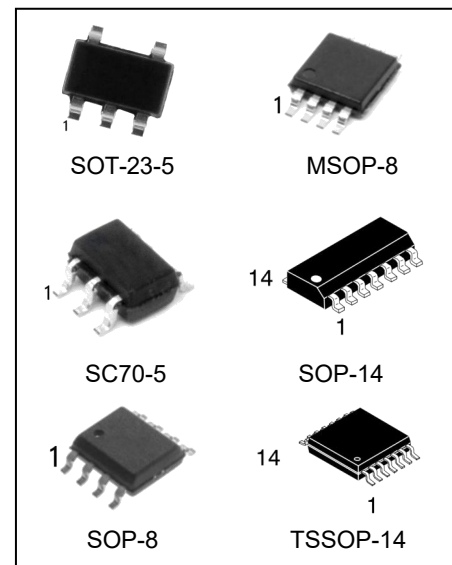

### ORDERING INFORMATION

DEVICE	Package Type	MARKING	Packing	Packing Qty
OPA348M5/TR	SOT-23-5	A348	REEL	3000pcs/reel
OPA348M7/TR	SC70-5	A348	REEL	3000pcs/reel
OPA348M/TR	SOP-8	OPA348	REEL	2500pcs/reel
OPA2348M/TR	SOP-8	OPA2348,A2348	REEL	2500pcs/reel
OPA2348MM/TR	MSOP-8	A2348	REEL	3000pcs/reel
OPA4348M/TR	SOP-14	OPA4348	REEL	2500pcs/reel
OPA4348MT/TR	TSSOP-14	OPA4348,A4348	REEL	2500pcs/reel

## DESCRIPTION

The OPA348 series amplifiers are single supply, low-power, CMOS opamps in micro packaging. Featuring an extended bandwidth of 1MHz, and a supply current of 45 $\mu$ A, the OPA348 series is useful for low-power applications on single supplies of 2.1V to 5.5V.

Low supply current of 45 $\mu$ A, and an input bias current of 0.5pA, make the OPA348 series an optimal candidate for low-power, high-impedance applications such as smoke detectors and other sensors.

The OPA348 is available in the miniature SC70-5, SOT23-5 and SOP-8 packages. The OPA2348 is available in MSOP-8 and SOP-8 packages, and the OPA4348 is offered in space-saving TSSOP-14 and SOP-14 packages. The extended temperature range of -40°C to +125°C over all supply voltages offers additional design flexibility.

## APPLICATIONS

- PORTABLE EQUIPMENT
- BATTERY-POWERED EQUIPMENT
- SMOKE ALARMS
- CO DETECTORS
- MEDICAL INSTRUMENTATION

## PIN ASSIGNMENT

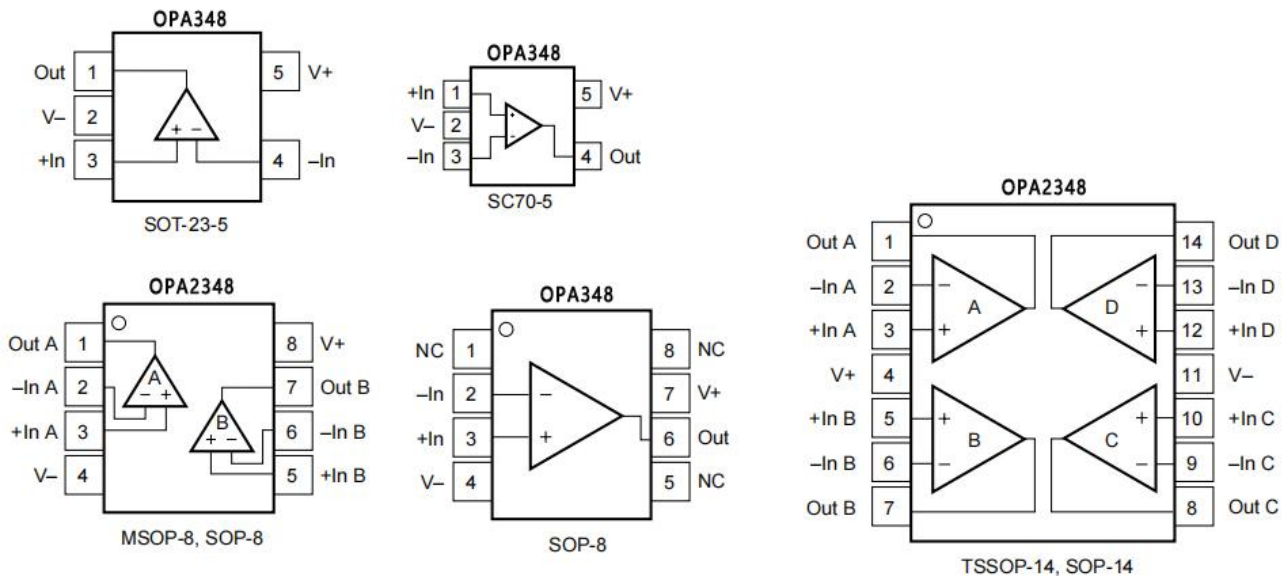

**ABSOLUTE MAXIMUM RATINGS<sup>(1)</sup>**

CONDITION	MIN	MAX	UNITS
Supply Voltage		7.5	V
Signal Input Terminals Voltage <sup>(2)</sup>	(V <sub>-</sub> )-0.5	(V <sub>+</sub> )+0.5	V
Signal Input Terminals Current <sup>(2)</sup>	10		mA
Output Short-Circuit <sup>(3)</sup>	Continuous		
Operating Temperature	-40	+125	°C
Storage Temperature	-65	+150	°C
Junction Temperature	150		°C
Lead Temperature (soldering, 10s)	245		°C

**NOTES:**

(1) Stresses above these ratings may cause permanent damage. Exposure to absolute maximum conditions for extended periods may degrade device reliability. These are stress ratings only. Functional operation of the device at these conditions, or beyond the specified operating conditions, is not implied. (2) Input terminals are diode-clamped to the power-supply rails. Input signals that can swing more than 0.5V beyond the supply rails should be current-limited to 10mA or less. (3) Short-circuit to ground, one amplifier per package.

**ELECTROSTATIC DISCHARGE SENSITIVITY**

This integrated circuit can be damaged by ESD. HGSEMI recommends that all integrated circuits be handled with appropriate precautions. Failure to observe proper handling and installation procedures can cause damage.

ESD damage can range from subtle performance degradation to complete device failure. Precision integrated circuits may be more susceptible to damage because very small parametric changes could cause the device not to meet its published specifications.

**ELECTRICAL CHARACTERISTICS:  $V_S = 2.5V$  to  $5.5V$** 

Boldface limits apply over the specified temperature range,  $T_A = -40^{\circ}C$  to  $+125^{\circ}C$  At  $T_A = +25^{\circ}C$ ,  $R_L = 100k\Omega$  connected to  $V_S/2$  and  $V_{OUT} = V_S/2$ , unless otherwise noted.

PARAMETER	CONDITION	OPA348/OPA2348/OPA4348			UNITS
		MIN	TYP	MAX	
OFFSET VOLTAGE	$V_S = 5V, V_{CM} = (V-) + 0.8V$		1	5	mV
Input Offset Voltage $V_{OS}$				6	mV
Over Temperature			4		$\mu/C$
Drift $dV_{OS}/dT$	$V_S = 2.5V$ to $5.5V, V_{CM} < (V+) - 1.7V$		60	175	$\mu/V$
vs Power Supply PSRR				300	$\mu/V$
Over Temperature	$V_S = 2.5V$ to $5.5V, V_{CM} < (V+) - 1.7V$		0.2		$\mu/V$
Channel Separation, $d_{cf} = 1kHz$			134		dB
<b>INPUT VOLTAGE RANGE</b>					
Common-Mode Voltage Range $V_{CM}$		$(V-) - 0.2$		$(V+) + 0.2$	V
Common-Mode Rejection Ratio $CMRR$	$(V-) - 0.2V < V_{CM} < (V+) - 1.7V$	70	82		dB
over Temperature	$(V-) - 0.2V < V_{CM} < (V+) - 1.7V$	66			dB
	$V_S = 5.5V, (V-) - 0.2 < V_{CM} < (V+) + 0.2V$	60	71		dB
over Temperature	$V_S = 5.5V, (V-) < V_{CM} < (V+)$	56			dB
<b>INPUT BIAS CURRENT</b>					
Input Bias Current $I_B$			0.5	10	pApA
Input Offset Current $I_{OS}$			0.5	10	pApA
<b>INPUT IMPEDANCE</b>					
Differential Common-Mode			$10^{13} \parallel 3$		$\Omega \parallel pF$
			$10^{13} \parallel 6$		$\Omega \parallel pF$
<b>NOISE</b>					
Input Voltage Noise, $f = 0.1Hz$ to $10Hz$	$V_{CM} < (V+) - 1.7V$		10		$V_p-p$
Input Voltage Noise Density, $f = 1kHz$ $e_n$			35		nV/Hz
Input Current Noise Density, $f = 1kHz$ $i_n$			4		fA/Hz
<b>OPEN-LOOP GAIN</b>					
Open-Loop Voltage Gain $A_{OL}$	$V_S = 5V, R_L = 100k\Omega, 0.025V < V_O < 4.975V$	94	108		dB
over Temperature	$V_S = 5V, R_L = 100k\Omega, 0.025V < V_O < 4.975V$	90			dB
	$V_S = 5V, R_L = 5k\Omega, 0.125V < V_O < 4.875V$	90	98		dB
over Temperature	$V_S = 5V, R_L = 5k\Omega, 0.125V < V_O < 4.875V$	88			dB
<b>OUTPUT</b>					
Voltage Output Swing from Rail	$R_L = 100k\Omega, A_{OL} > 94dB$		18	25	mV
over Temperature	$R_L = 100k\Omega, A_{OL} > 90dB$			25	mV
	$R_L = 5k\Omega, A_{OL} > 90dB$		100	125	mV
over Temperature	$R_L = 5k\Omega, A_{OL} > 88dB$			125	mV
Short-Circuit Current $I_{SC}$			10		mA
Capacitive Load Drive $C_L$ OAD		See Ty	pical Characte	ristics	
<b>FREQUENCY RESPONSE</b>					
Gain-Bandwidth Product GBW	$C_L = 100pF$		1		MHz
Slew Rate SR	$G = +1$		0.5		V/s
Settling Time, 0.1% $t_s$	$V_S = 5.5V, 2V$ Step, $G = +1$		5		$\mu s$
0.01%	$V_S = 5.5V, 2V$ Step, $G = +1$		7		$\mu s$
Overload Recovery Time	$V_{IN} \cdot Gain > V_S$		1.6		$\mu s$
Total Harmonic Distortion + Noise THD+N	$V_S = 5.5V, V_O = 3V_p-p, G = +1, f = 1kHz$		0.0023		%
<b>POWER SUPPLY</b>					
Specified Voltage Range $V_S$		2.5		5.5	V
Minimum Operating Voltage			2.1 to 5.5		V
Quiescent Current (per amplifier) $I_Q$	$I_O = 0$		45	65	$\mu A$
over Temperature				75	$\mu A$
<b>TEMPERATURE RANGE</b>					
Specified Range		-40		125	$^{\circ}C$
Operating Range		-65		150	$^{\circ}C$
Storage Range		-65		150	$^{\circ}C$
Thermal Resistance $J_A$					
SOT23-5 Surface-Mount			200		$^{\circ}C/W$
SOT23-8 Surface-Mount			150		$^{\circ}C/W$
MSOP-8 Surface-Mount			150		$^{\circ}C/W$
SO-8 Surface-Mount			150		$^{\circ}C/W$
SO-14 Surface-Mount			100		$^{\circ}C/W$
TSSOP-14 Surface-Mount			100		$^{\circ}C/W$
SC70-5 Surface-Mount			250		$^{\circ}C/W$

## TYPICAL CHARACTERISTICS

At  $T_A = +25^\circ\text{C}$ ,  $R_L = 100\text{k}\Omega$  connected to  $V_S / 2$  and  $V_{OUT} = V_S / 2$ , unless otherwise noted.

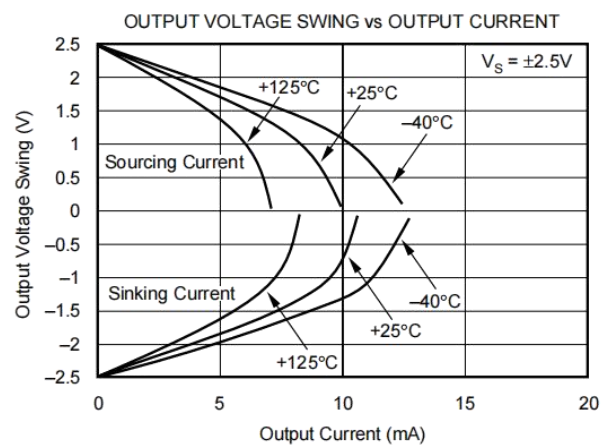
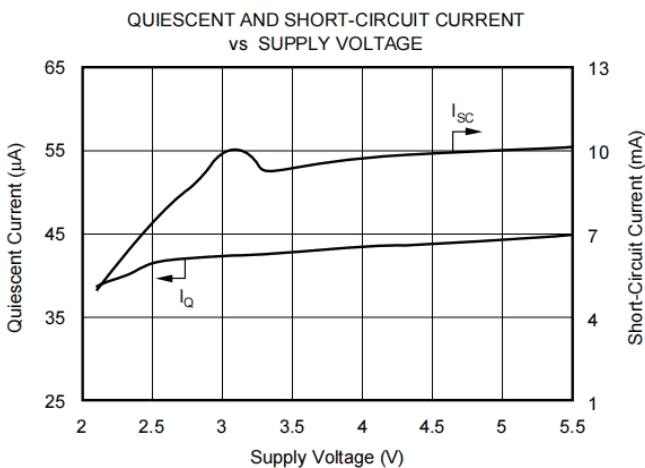
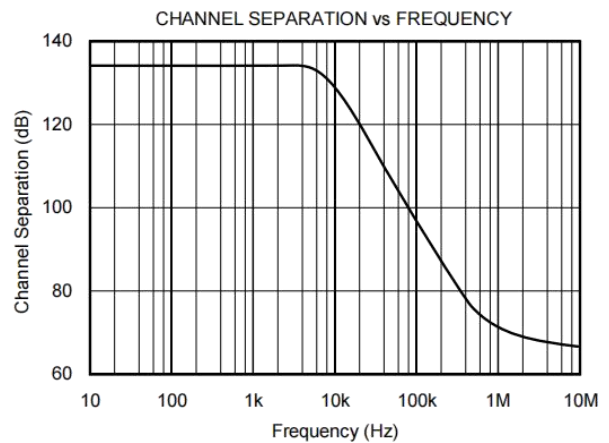
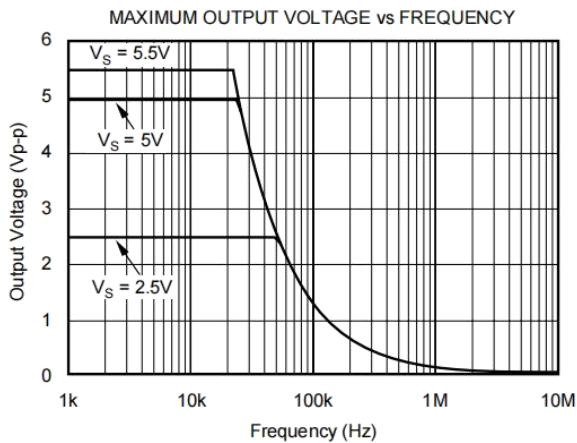
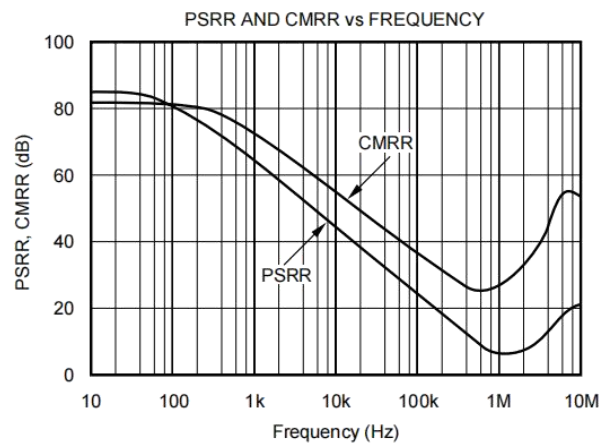
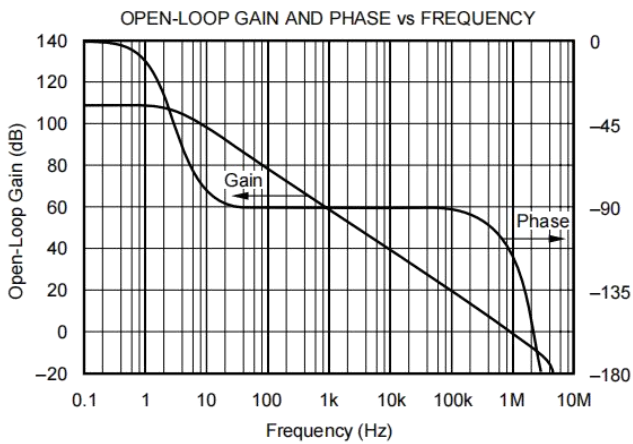

**TYPICAL CHARACTERISTICS (Cont.)**

At  $T_A = +25^\circ\text{C}$ ,  $R_L = 100\text{k}\Omega$  connected to  $V_S / 2$  and  $V_{OUT} = V_S / 2$ , unless otherwise noted.

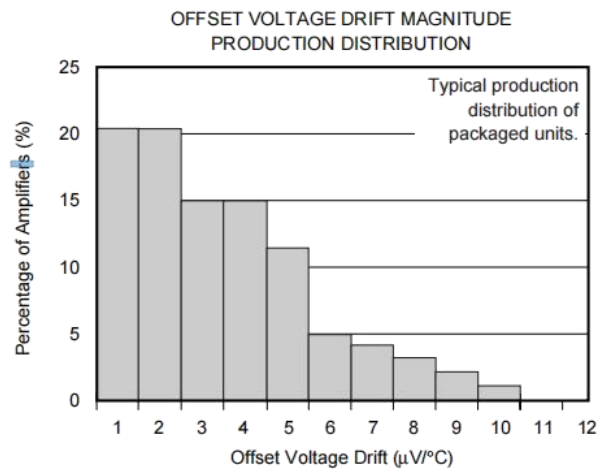
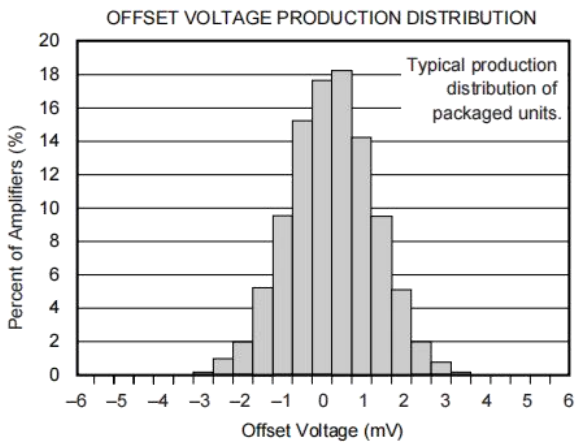
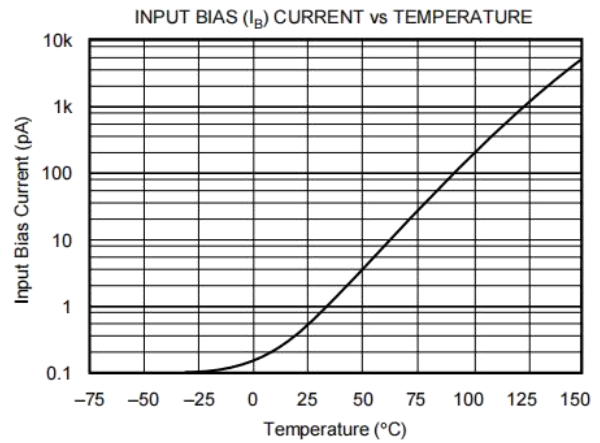
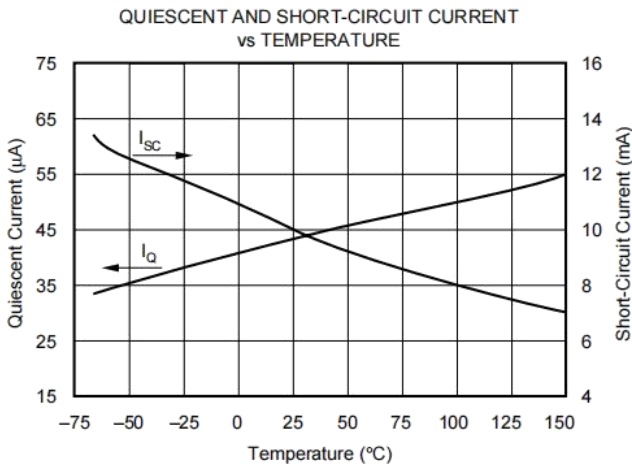
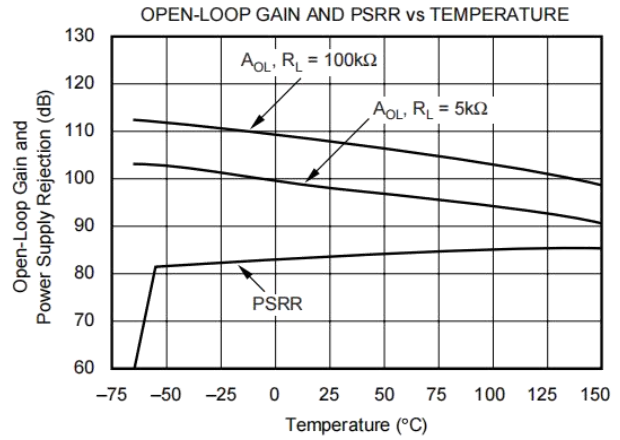
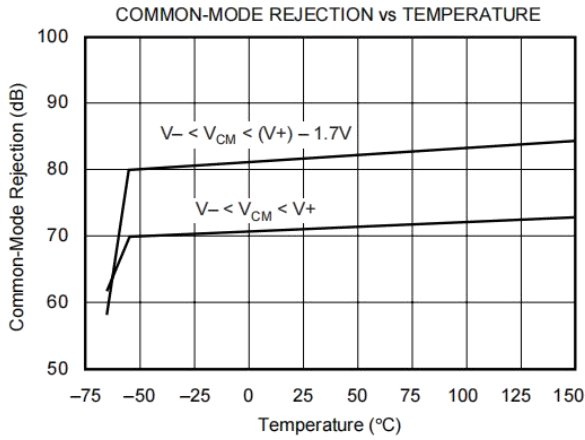

**TYPICAL CHARACTERISTICS (Cont.)**

At TA = +25°C, RL = 100kΩ connected to VS / 2 and VOUT = VS / 2, unless otherwise noted

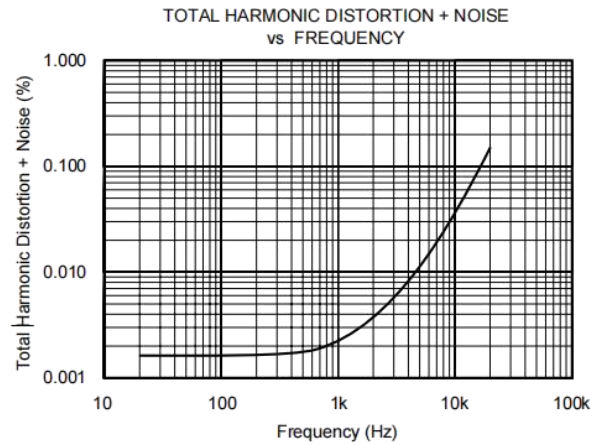
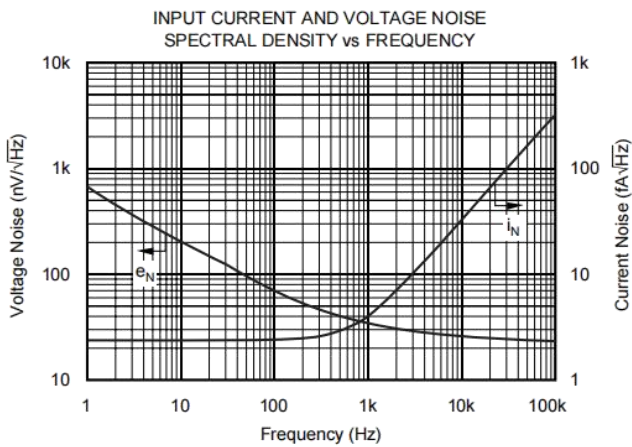
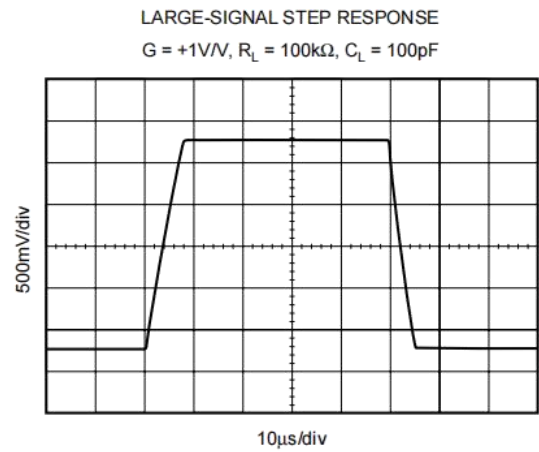
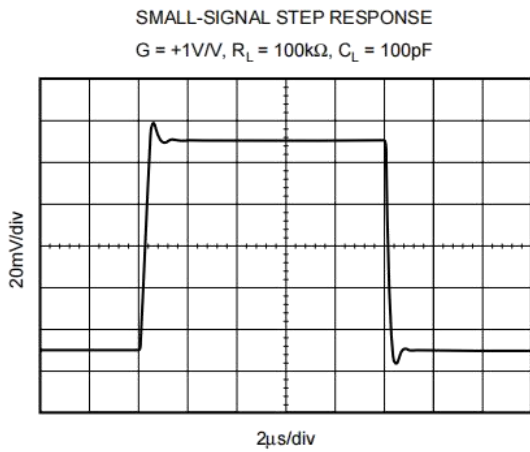
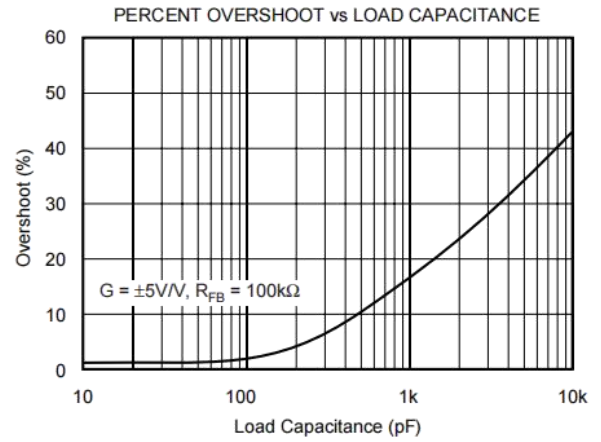
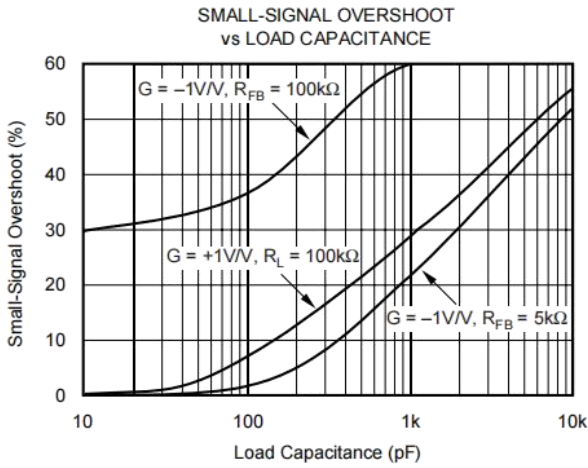

## APPLICATIONS INFORMATION

OPA348 series op amps are unity-gain stable and suitable for a wide range of general-purpose applications.

The OPA348 series features wide bandwidth and unity-gain stability with rail-to-rail input and output for increased dynamic range. Figure 1 shows the input and output waveforms for the OPA348 in unity-gain configuration. Operation is from a single +5V supply with a 100kΩ load connected to VS/2. The input is a 5Vp-p sinusoid. Output voltage is approximately 4.98Vp-p. Power-supply pins should be bypassed with 0.01μF ceramic capacitors.

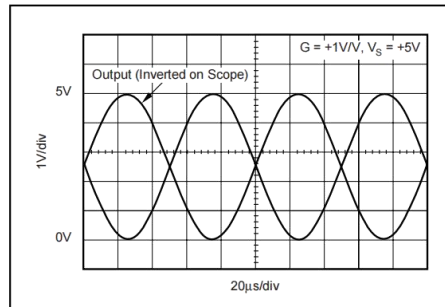

FIGURE 1. The OPA348 Features Rail-to-Rail Input/Output.

## OPERATING VOLTAGE

OPA348 series op amps are fully specified and tested from +2.5V to +5.5V. However, supply voltage may range from +2.1V to +5.5V. Parameters are tested over the specified supply range—a unique feature of the OPA348 series. In addition, all temperature specifications apply from -40°C to +125°C. Most behavior remains virtually unchanged through out the full operating voltage range. Parameters that vary significantly with operating voltages or temperature are shown in the Typical Characteristics.

## COMMON-MODE VOLTAGE RANGE

The input common-mode voltage range of the OPA348 series extends 200mV beyond the supply rails. This is achieved with a complementary input stage—an N-channel input differential pair in parallel with a P-channel differential pair. The N-channel pair is active for input voltages close to the positive rail, typically  $(V+) - 1.2V$  to 300mV above the positive supply, while the P-channel pair is on for inputs from 300mV below the negative supply to approximately  $(V+) - 1.4V$ . There is a small transition region, typically  $(V+) - 1.4V$  to  $(V+) - 1.2V$ , in which both pairs are on. This 200mV transition region, shown in Figure 2, can vary  $\pm 300mV$  with process variation. Thus, the transition region (both stages on) can range from  $(V+) - 1.7V$  to  $(V+) - 1.5V$  on the low end, up to  $(V+) - 1.1V$  to  $(V+) - 0.9V$  on the high end. Within the 200mV transition region PSRR, CMRR, offset voltage, offset drift, and THD may be degraded compared to operation outside this region.

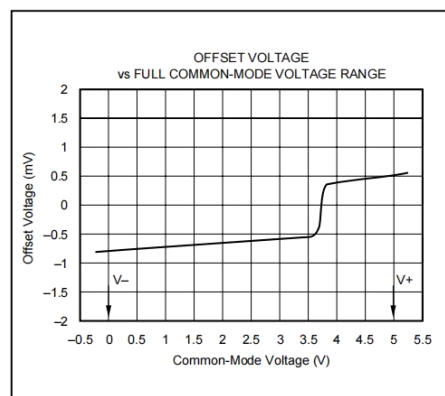
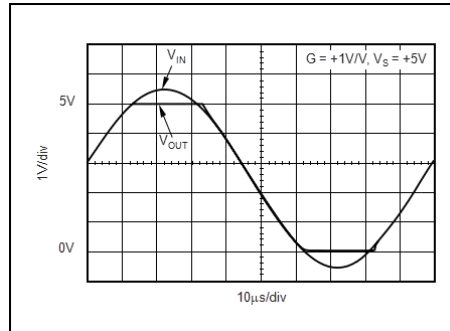

FIGURE 2. Behavior of Typical Transition Region at Room Temperature.



## RAIL-TO-RAIL INPUT

The input common-mode range extends from  $(V-) - 0.2V$  to  $(V+) + 0.2V$ . For normal operation, inputs should be limited to this range. The absolute maximum input voltage is 500mV beyond the supplies. Inputs greater than the input common-mode range but less than the maximum input voltage, while not valid, will not cause any damage to the op amp. Unlike some other op amps, if input current is limited the inputs may go beyond the power supplies without phase inversion, as shown in Figure 3.



**FIGURE 3. OPA348—No Phase Inversion with Inputs Greater than the Power-Supply Voltage.**

Normally, input currents are 0.5pA. However, large inputs (greater than 500mV beyond the supply rails) can cause excessive current to flow in or out of the input pins. Therefore, as well as keeping the input voltage below the maximum rating, it is also important to limit the input current to less than 10mA. This is easily accomplished with an input voltage resistor, as shown in Figure 4.

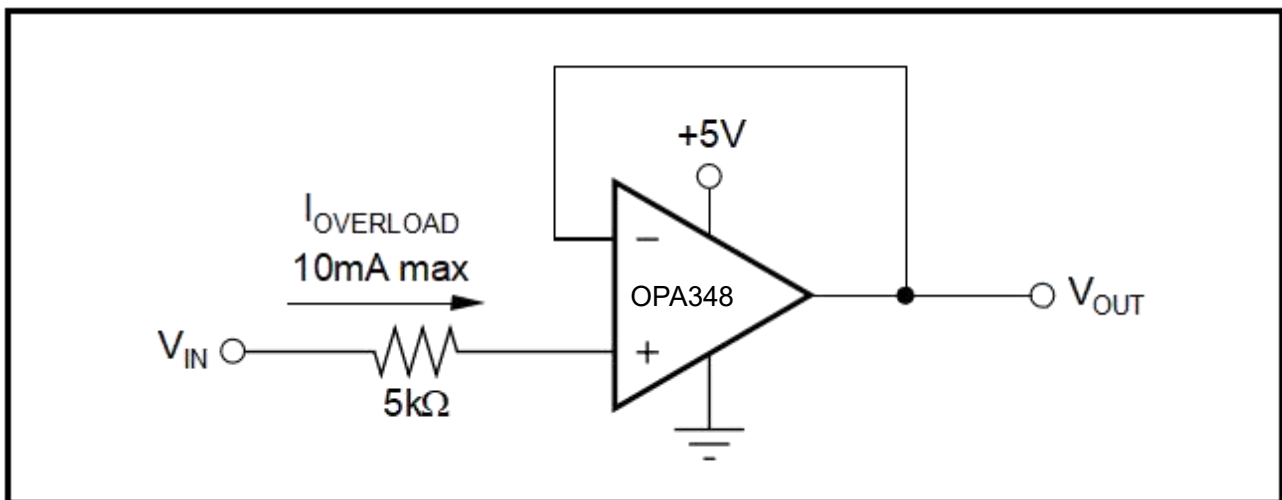

**FIGURE 4. Input Current Protection for Voltages Exceeding the Supply Voltage.**

## RAIL-TO-RAIL OUTPUT

A class AB output stage with common-source transistors is used to achieve rail-to-rail output. This output stage is capable of driving 5kΩ loads connected to any potential between V+ and ground. For light resistive loads ( $> 100k\Omega$ ), the output voltage can typically swing to within 18mV from supply rail. With moderate resistive loads (10kΩ to 50kΩ), the output voltage can typically swing to within 100mV of the supply rails while maintaining high open-loop gain (see the typical characteristic “Output Voltage Swing vs Output Current”).

## CAPACITIVE LOAD AND STABILITY

The OPA348 in a unity-gain configuration can directly drive up to 250pF pure capacitive load. Increasing the gain enhances the amplifier's ability to drive greater capacitive loads (see the typical characteristic "Small-Signal Overshoot vs Capacitive Load"). In unity-gain configurations, capacitive load drive can be improved by inserting a small ( $10\Omega$  to  $20\Omega$ ) resistor,  $R_S$ , in series with the output, as shown in Figure 5. This significantly reduces ringing while maintaining DC performance for purely capacitive loads. However, if there is a resistive load in parallel with the capacitive load, a voltage divider is created, introducing a Direct Current (DC) error at the output and slightly reducing the output swing. The error introduced is proportional to the ratio  $R_S/R_L$ , and is generally negligible.

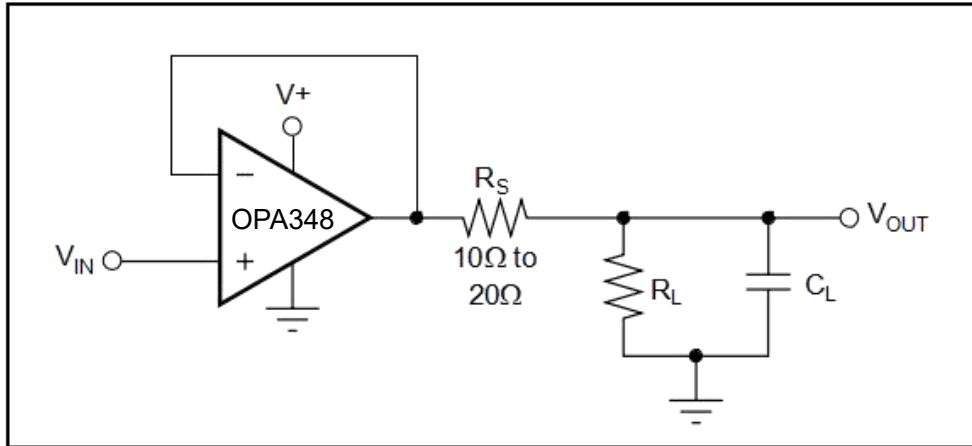

**FIGURE 5. Series Resistor in Unity-Gain Buffer Configuration Improves Capacitive Load Drive.**

In unity-gain inverter configuration, phase margin can be reduced by the reaction between the capacitance at the op amp input, and the gain setting resistors, thus degrading capacitive load drive. Best performance is achieved by using small valued resistors. For example, when driving a 500pF load, reducing the resistor values from  $100k\Omega$  to  $5k\Omega$  decreases overshoot from 55% to 13% (see the typical characteristic "Small-Signal Overshoot vs. Load Capacitance"). However, when large valued resistors cannot be avoided, a small ( $4pF$  to  $6pF$ ) capacitor,  $C_{FB}$ , can be inserted in the feedback, as shown in Figure 6. This significantly reduces overshoot by compensating the effect of capacitance,  $C_{IN}$ , which includes the amplifier's input capacitance and PC board parasitic capacitance.

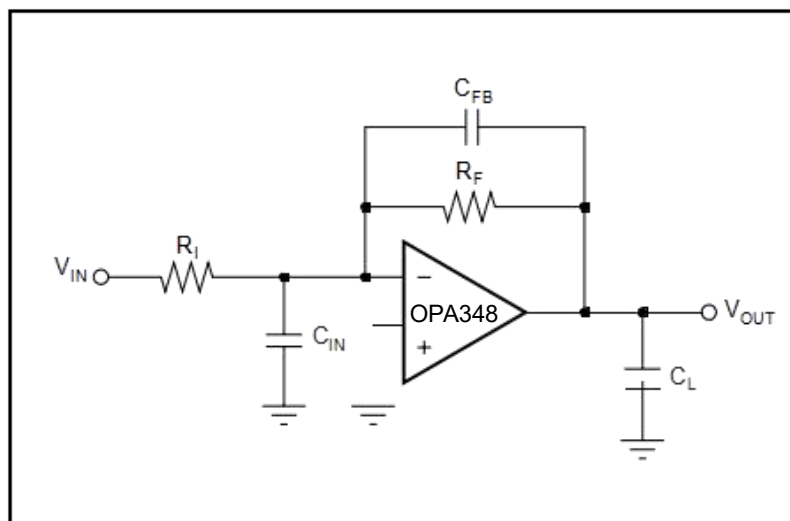

**FIGURE 6. Improving Capacitive Load Drive.**

---

## DRIVING A/D CONVERTERS

The OPA348 series op amps are optimized for driving medium-speed sampling Analog-to-Digital Converters (ADCs). The OPA348 op amps buffer the ADCs input capacitance and resulting charge injection while providing signal gain.

The OPA348 in a basic noninverting configuration driving the ADS7822, see Figure 7. The ADS7822 is a 12-bit, microPOWER sampling converter in the MSOP-8 package. When used with the low-power, miniature packages of the OPA348, the combination is ideal for space-limited, low-power applications. In this configuration, an RC network at the ADC's input can be used to provide for anti-aliasing filter and charge injection current.

The OPA348 in noninverting configuration driving ADS7822 limited, low-power applications. In this configuration, an RC network at the ADC's input can be used to provide for anti-aliasing filter and charge injection current. See Figure 8 for the OPA2348 driving an ADS7822 in a speech bandpass filtered data acquisition system. This small, low-cost solution provides the necessary amplification and signal conditioning to interface directly with an electret microphone. This circuit will operate with  $V_S = 2.7V$  to  $5V$  with less than  $250\mu A$  typical quiescent current.

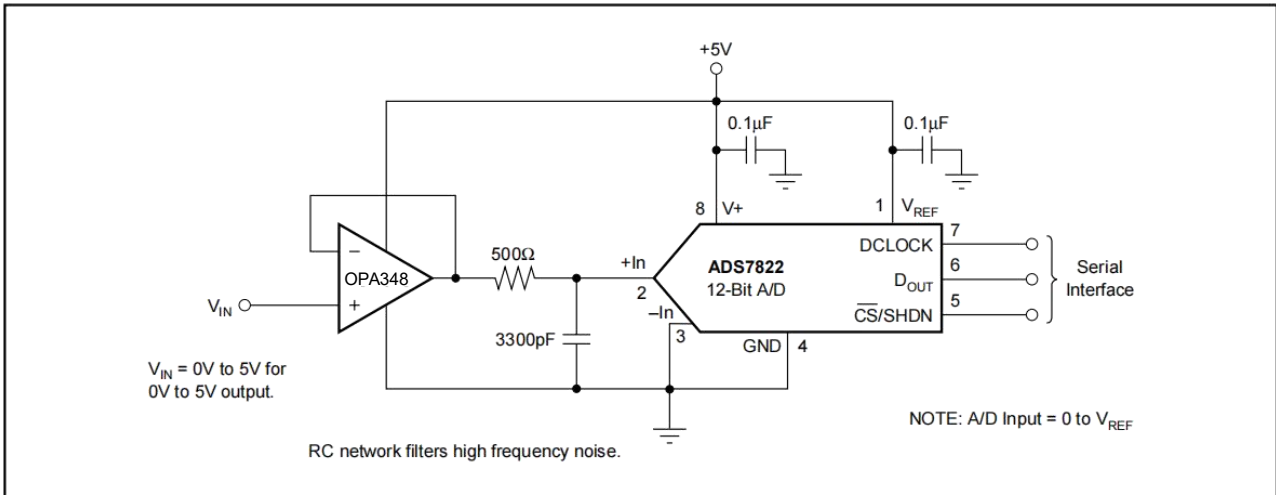
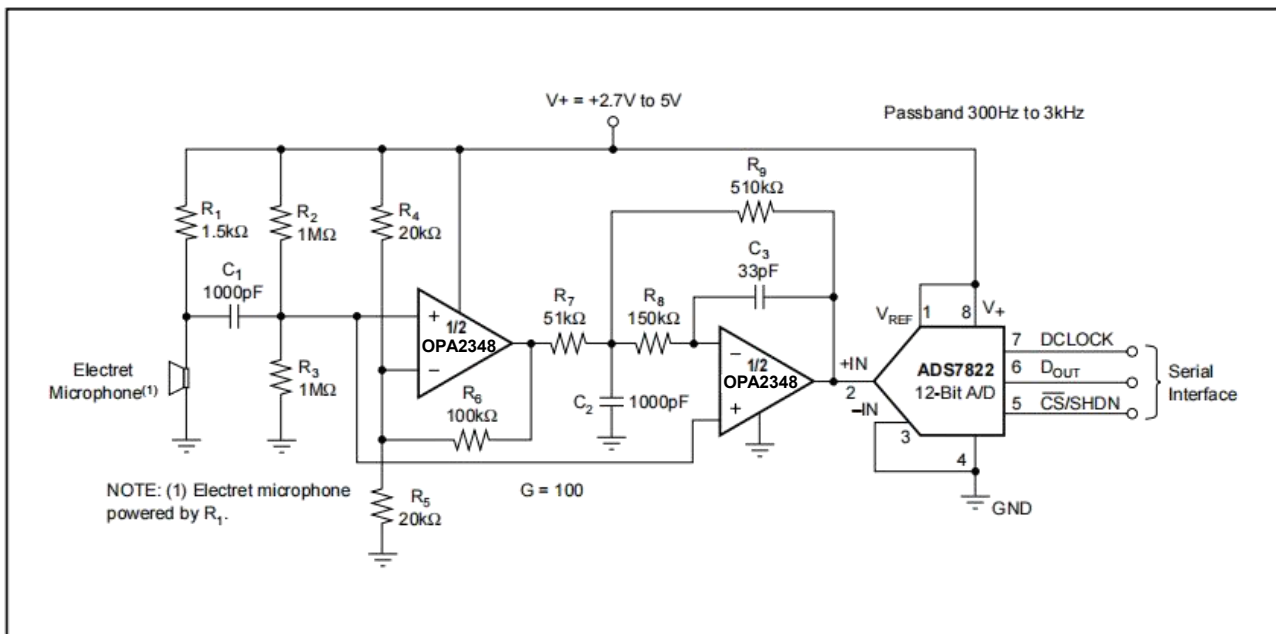

FIGURE 7. OPA348 in Noninverting Configuration Driving ADS7822.

FIGURE 8. OPA2348 as a Speech Bandpass Filtered Data Acquisition System.



**PHYSICAL DIMENSIONS**

SOP-8

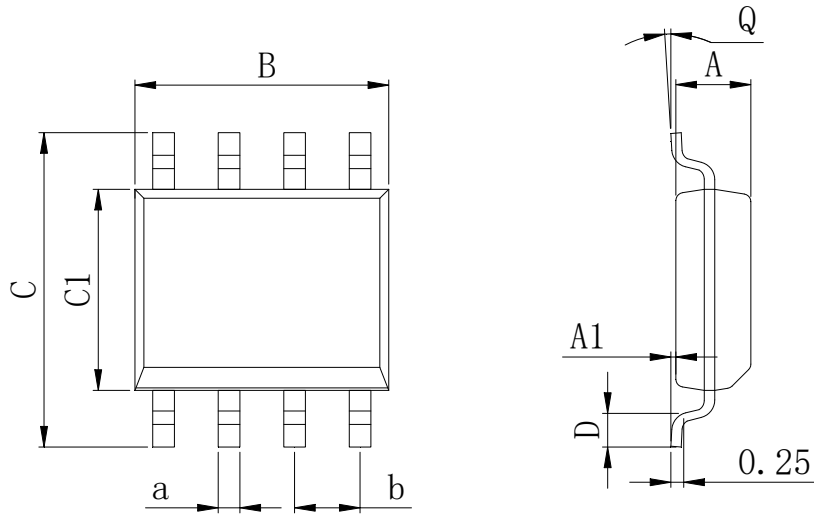

Dimensions In Millimeters(SOP-8)

Symbol:	A	A1	B	C	C1	D	Q	a	b
Min:	1.35	0.05	4.90	5.80	3.80	0.40	0°	0.35	1.27 BSC
Max:	1.55	0.20	5.10	6.20	4.00	0.80	8°	0.45	

MSOP-8

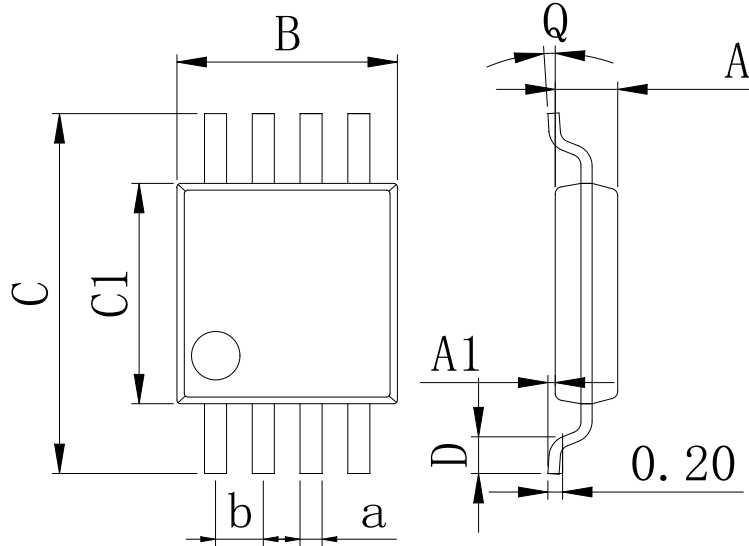

Dimensions In Millimeters(MSOP-8)

Symbol:	A	A1	B	C	C1	D	Q	a	b
Min:	0.80	0.05	2.90	4.75	2.90	0.35	0°	0.25	0.65 BSC
Max:	0.90	0.20	3.10	5.05	3.10	0.75	8°	0.35	

**PHYSICAL DIMENSIONS**

SOP-14

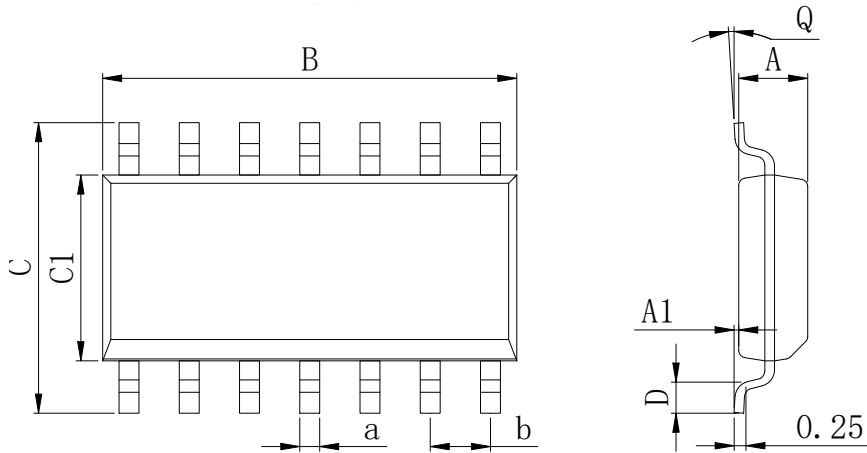

Dimensions In Millimeters(SOP-14)									
Symbol:	A	A1	B	C	C1	D	Q	a	b
Min:	1.35	0.05	8.55	5.80	3.80	0.40	0°	0.35	1.27 BSC
Max:	1.55	0.20	8.75	6.20	4.00	0.80	8°	0.45	

TSSOP-14

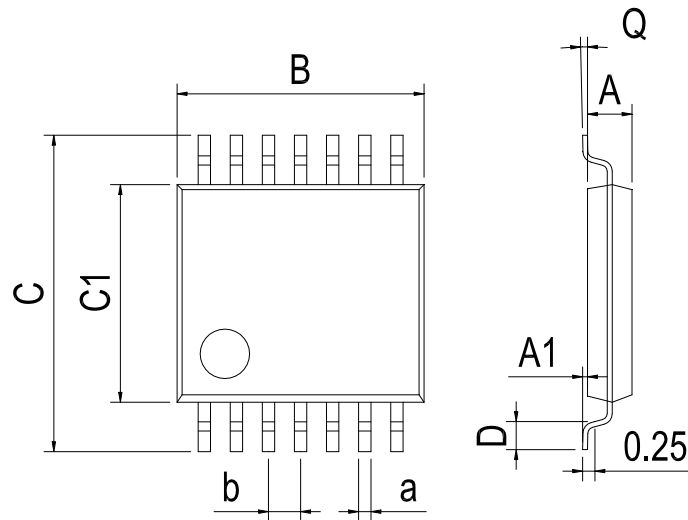

Dimensions In Millimeters(TSSOP-14)									
Symbol:	A	A1	B	C	C1	D	Q	a	b
Min:	0.85	0.05	4.90	6.20	4.30	0.40	0°	0.20	0.65 BSC
Max:	0.95	0.20	5.10	6.60	4.50	0.80	8°	0.25	

**PHYSICAL DIMENSIONS**

SOT-23-5

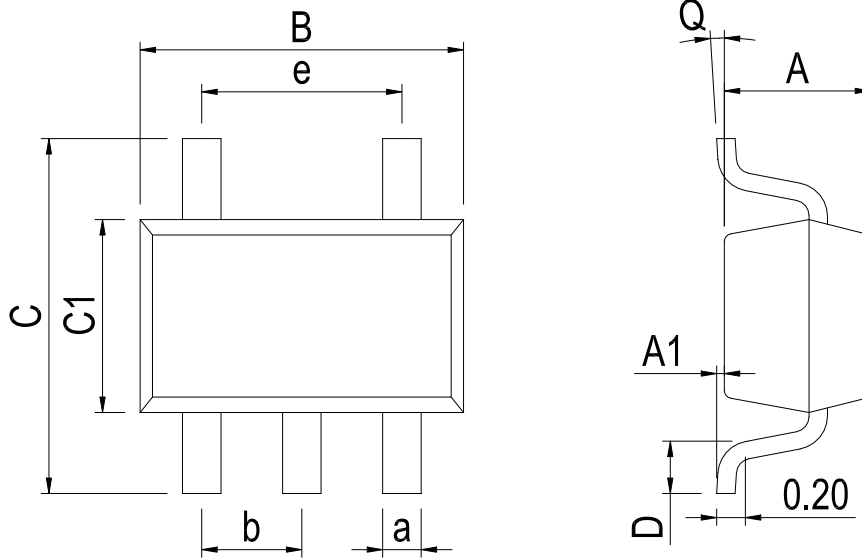

Dimensions In Millimeters(SOT-23-5)										
Symbol:	A	A1	B	C	C1	D	Q	a	b	e
Min:	1.05	0.00	2.82	2.65	1.50	0.30	0°	0.30	0.95 BSC	1.90 BSC
Max:	1.15	0.15	3.02	2.95	1.70	0.60	8°	0.40		

SC70-5

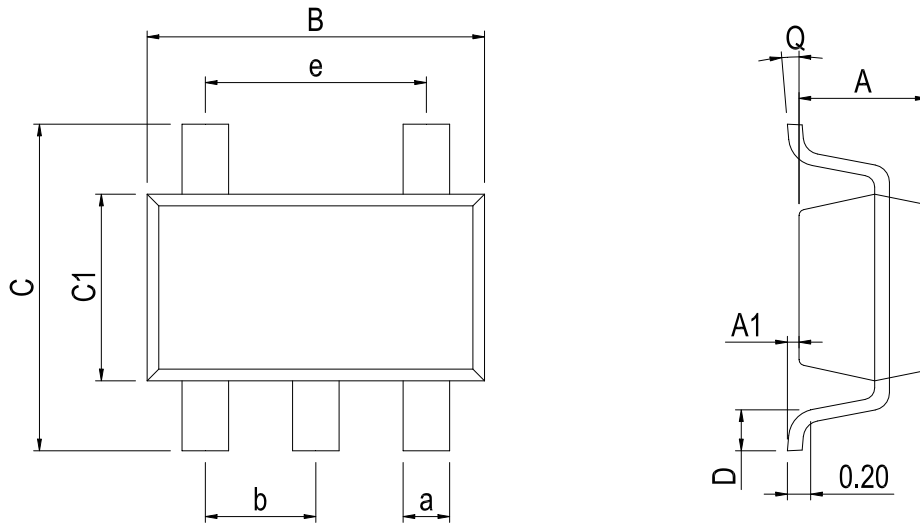

Dimensions In Millimeters(SC70-5)										
Symbol:	A	A1	B	C	C1	D	Q	a	b	e
Min:	0.90	0.00	2.00	2.15	1.15	0.26	0°	0.15	0.65	1.30 BSC
Max:	1.00	0.15	2.20	2.45	1.35	0.46	8°	0.35	BSC	

**REVISION HISTORY**

DATE	REVISION	PAGE
2019-12-15	New	1-17
2023-10-31	Update Lead Temperature、 Update encapsulation type、 Update SC70-5 Physical Dimensions	3、 1、 15



**IMPORTANT STATEMENT:**

Huaguan Semiconductor reserves the right to change its products and services without notice. Before ordering, the customer shall obtain the latest relevant information and verify whether the information is up to date and complete. Huaguan Semiconductor does not assume any responsibility or obligation for the altered documents.

Customers are responsible for complying with safety standards and taking safety measures when using Huaguan Semiconductor products for system design and machine manufacturing. You will bear all the following responsibilities: Select the appropriate Huaguan Semiconductor products for your application; Design, validate and test your application; Ensure that your application meets the appropriate standards and any other safety, security or other requirements. To avoid the occurrence of potential risks that may lead to personal injury or property loss.

Huaguan Semiconductor products have not been approved for applications in life support, military, aerospace and other fields, and Huaguan Semiconductor will not bear the consequences caused by the application of products in these fields. All problems, responsibilities and losses arising from the user's use beyond the applicable area of the product shall be borne by the user and have nothing to do with Huaguan Semiconductor, and the user shall not claim any compensation liability against Huaguan Semiconductor by the terms of this Agreement.

The technical and reliability data (including data sheets), design resources (including reference designs), application or other design suggestions, network tools, safety information and other resources provided for the performance of semiconductor products produced by Huaguan Semiconductor are not guaranteed to be free from defects and no warranty, express or implied, is made. The use of testing and other quality control technologies is limited to the quality assurance scope of Huaguan Semiconductor. Not all parameters of each device need to be tested.

The documentation of Huaguan Semiconductor authorizes you to use these resources only for developing the application of the product described in this document. You have no right to use any other Huaguan Semiconductor intellectual property rights or any third party intellectual property rights. It is strictly forbidden to make other copies or displays of these resources. You should fully compensate Huaguan Semiconductor and its agents for any claims, damages, costs, losses and debts caused by the use of these resources. Huaguan Semiconductor accepts no liability for any loss or damage caused by infringement.

## X-ON Electronics

Largest Supplier of Electrical and Electronic Components

*Click to view similar products for [Operational Amplifiers - Op Amps](#) category:*

*Click to view products by [HGSEMI](#) manufacturer:*

Other Similar products are found below :

[430227FB](#) [UPC451G2-A](#) [UPC824G2-A](#) [LT1678IS8](#) [UPC258G2-A](#) [NCV33202DMR2G](#) [NJM324E](#) [M38510/13101BPA](#) [NTE925](#)  
[AZV358MTR-G1](#) [AP4310AUMTR-AG1](#) [AZV358MMTR-G1](#) [SCY33178DR2G](#) [NCV5652MUTWG](#) [NCV20034DR2G](#) [NTE778S](#) [NTE871](#)  
[NTE937](#) [MCP6V16UT-E/OT](#) [SCY6358ADR2G](#) [UPC4570G2-E1-A](#) [NCS20282FCTTAG](#) [UPC834G2-E1-A](#) [UPC1458G2-E2-A](#) [UPC813G2-](#)  
[E2-A](#) [UPC458G2-E1-A](#) [UPC824G2-E2-A](#) [UPC4574G2-E2-A](#) [UPC4558G2-E2-A](#) [UPC4560G2-E1-A](#) [UPC258G2-E1-A](#) [UPC4742GR-9LG-](#)  
[E1-A](#) [UPC4742G2-E1-A](#) [UPC832G2-E2-A](#) [UPC842G2-E1-A](#) [UPC802G2-E1-A](#) [UPC4741G2-E2-A](#) [UPC4572G2-E2-A](#) [UPC844GR-9LG-](#)  
[E2-A](#) [UPC259G2-E1-A](#) [UPC4741G2-E1-A](#) [UPC4558G2-E1-A](#) [UPC1251GR-9LG-E1-A](#) [UPC4744G2-E1-A](#) [UPC4092G2-E1-A](#)  
[UPC4574G2-E1-A](#) [UPC4062G2-E2-A](#) [UPC451G2-E2-A](#) [UPC832G2-E1-A](#) [UPC844GR-9LG-E1-A](#)