

Remote 8-bit I/O expander for I²C-bus

FEATURES

- Operating supply voltage 2.5 to 6 V
- Low standby current consumption of 10 μ A maximum
- I²C to parallel port expander
- Open-drain interrupt output
- 8-bit remote I/O port for the I²C-bus
- Compatible with most microcontrollers
- Latched outputs with high current drive capability for directly driving LEDs
- Address by 3 hardware address pins for use of up to 8 devices (up to 16 with PCF8574A)
- DIP16, or space-saving SOP16 or SSOP20 packages.

GENERAL DESCRIPTION

The PCF8574 is a silicon CMOS circuit. It provides general purpose remote I/O expansion for most microcontroller families via the two-line bidirectional bus (I²C).

The device consists of an 8-bit quasi-bidirectional port and an I²C-bus interface. The PCF8574 has a low current consumption and includes latched outputs with high current drive capability for directly driving LEDs. It also possesses an interrupt line (INT) which can be connected to the interrupt logic of the microcontroller. By sending an interrupt signal on this line, the remote I/O can inform the microcontroller if there is incoming data on its ports without having to communicate via the I²C-bus. This means that the PCF8574 can remain a simple slave device.

The PCF8574 and PCF8574A versions differ only in their slave address as shown in Fig.9.

ORDERING INFORMATION

DEVICE	Package Type	MARKING	Packing	Packing Qty
PCF8574AN	DIP16L	PCF8574A	TUBE	1000pcs/box
PCF8574AT/TR	SOP16W	PCF8574A	REEL	2000pcs/reel
PCF8574AM/TR	SOP16L	PCF8574A	REEL	2500pcs/reel
PCF8574AMS/TR	SSOP20L	PCF8574A	REEL	2000pcs/reel
PCF8574N	DIP16L	PCF8574	TUBE	1000pcs/box
PCF8574T/TR	SOP16W	PCF8574	REEL	2000pcs/reel
PCF8574M/TR	SOP16L	PCF8574	REEL	2500pcs/reel
PCF8574MS/TR	SSOP20L	PCF8574	REEL	2000pcs/reel

BLOCK DIAGRAM

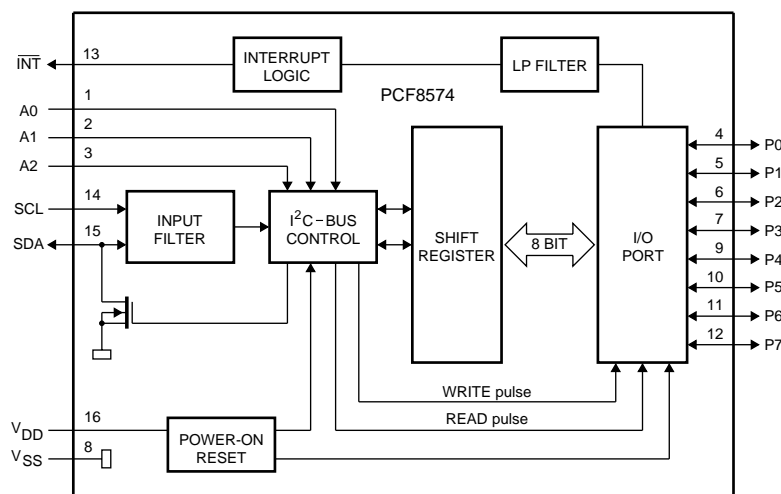
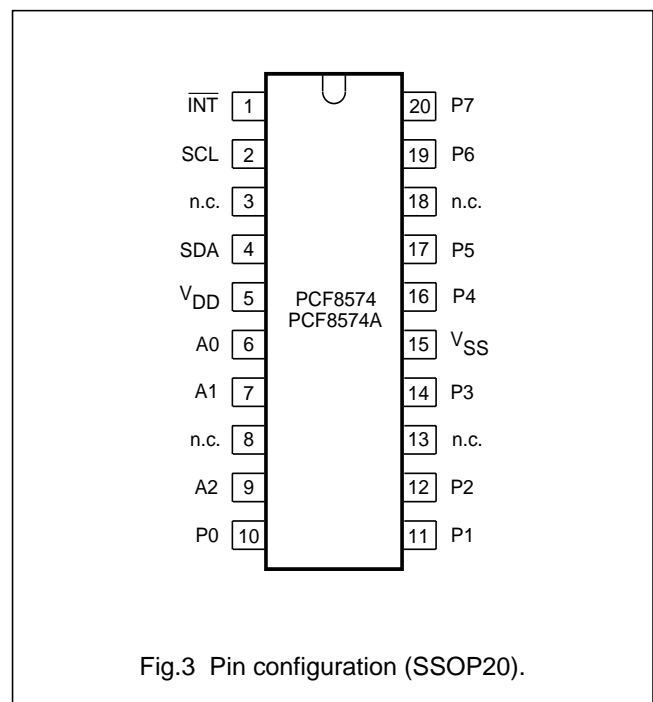
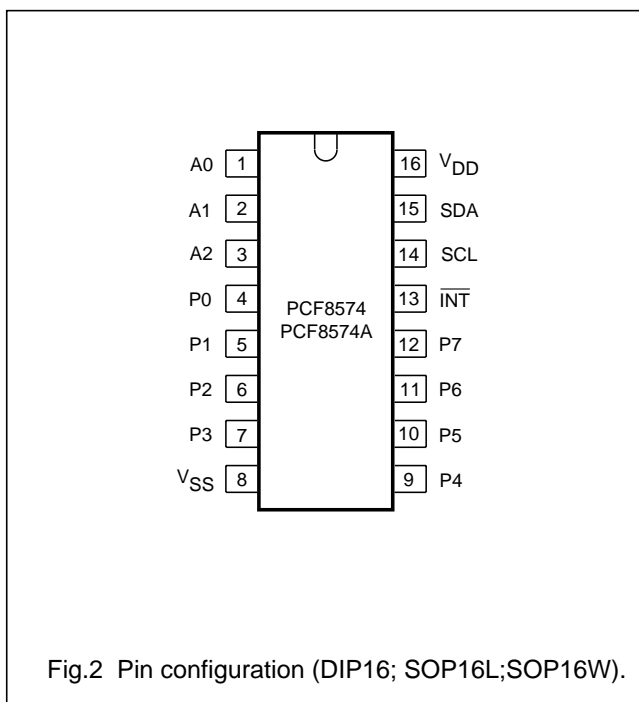

Fig.1 Block diagram (SOT38-1 and SOT162-1).

PINNING

SYMBOL	PIN		DESCRIPTION
	DIP16; SOP16	SSOP20	
A0	1	6	address input 0
A1	2	7	address input 1
A2	3	9	address input 2
P0	4	10	quasi-bidirectional I/O 0
P1	5	11	quasi-bidirectional I/O 1
P2	6	12	quasi-bidirectional I/O 2
P3	7	14	quasi-bidirectional I/O 3
V _{SS}	8	15	supply ground
P4	9	16	quasi-bidirectional I/O 4
P5	10	17	quasi-bidirectional I/O 5
P6	11	19	quasi-bidirectional I/O 6
P7	12	20	quasi-bidirectional I/O 7
$\overline{\text{INT}}$	13	1	interrupt output (active LOW)
SCL	14	2	serial clock line
SDA	15	4	serial data line
V _{DD}	16	5	supply voltage
n.c.	–	3	not connected
n.c.	–	8	not connected
n.c.	–	13	not connected
n.c.	–	18	not connected



CHARACTERISTICS OF THE I²C-BUS

The I²C-bus is for 2-way, 2-line communication between different ICs or modules. The two lines are a serial data line (SDA) and a serial clock line (SCL). Both lines must be connected to a positive supply via a pull-up resistor when connected to the output stages of a device. Data transfer may be initiated only when the bus is not busy.

Bit transfer

One data bit is transferred during each clock pulse. The data on the SDA line must remain stable during the HIGH period of the clock pulse as changes in the data line at this time will be interpreted as control signals (see Fig.4).

Start and stop conditions

Both data and clock lines remain HIGH when the bus is not busy. A HIGH-to-LOW transition of the data line, while the clock is HIGH is defined as the start condition (S). A LOW-to-HIGH transition of the data line while the clock is HIGH is defined as the stop condition (P) (see Fig.5).

System configuration

A device generating a message is a 'transmitter', a device receiving is the 'receiver'. The device that controls the message is the 'master' and the devices which are controlled by the master are the 'slaves' (see Fig.6).

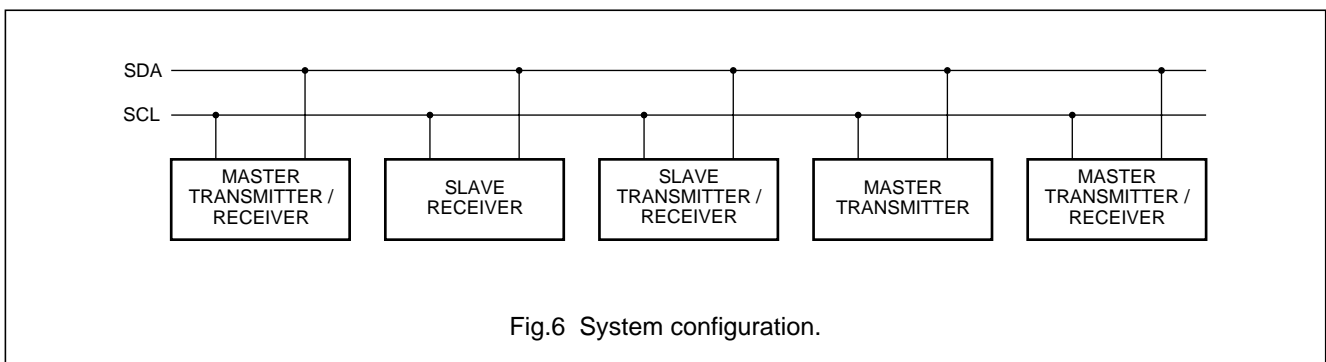
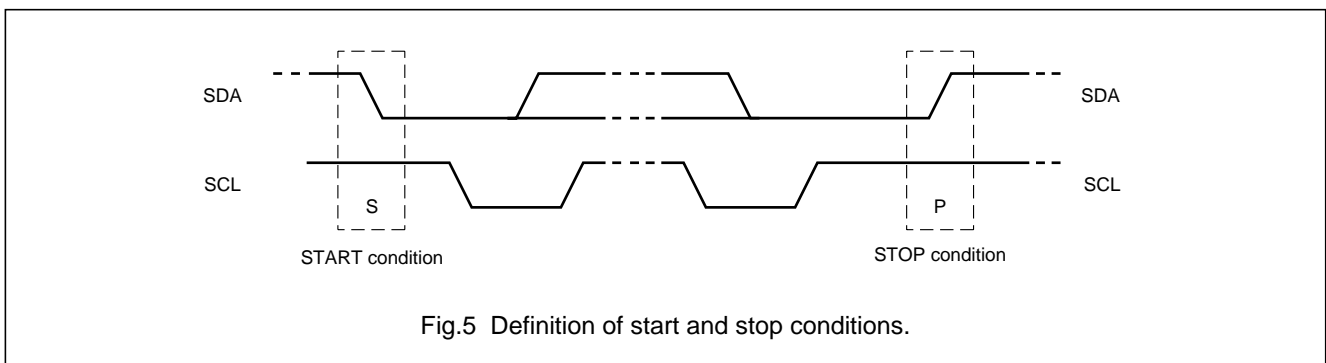
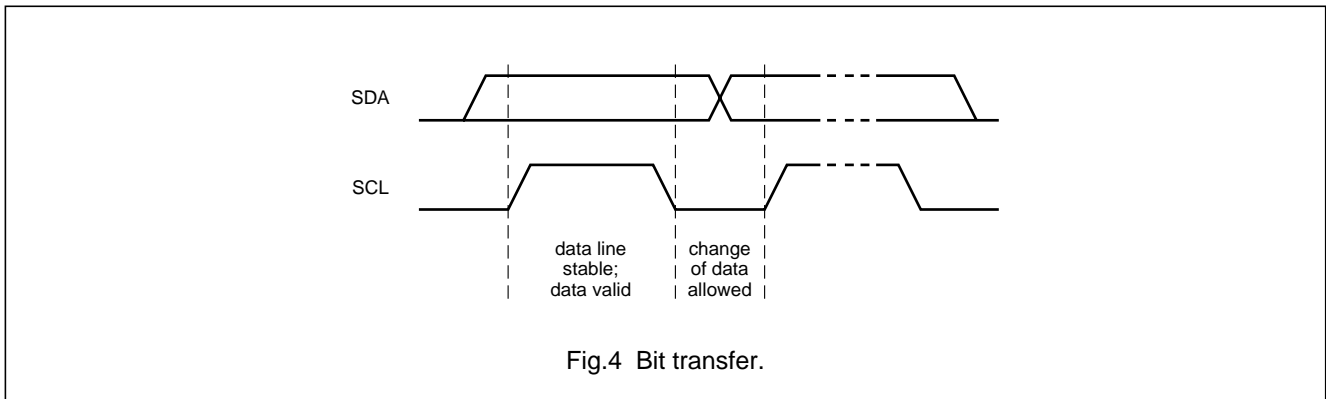

Acknowledge

The number of data bytes transferred between the start and the stop conditions from transmitter to receiver is not limited. Each byte of eight bits is followed by one acknowledge bit. The acknowledge bit is a HIGH level put on the bus by the transmitter whereas the master generates an extra acknowledge related clock pulse.

A slave receiver which is addressed must generate an acknowledge after the reception of each byte. Also a master must generate an acknowledge after the reception of each byte that has been clocked out of the slave

transmitter. The device that acknowledges has to pull down the SDA line during the acknowledge clock pulse, so that the SDA line is stable LOW during the HIGH period of the acknowledge related clock pulse, set-up and hold times must be taken into account.

A master receiver must signal an end of data to the transmitter by **not** generating an acknowledge on the last byte that has been clocked out of the slave. In this event the transmitter must leave the data line HIGH to enable the master to generate a stop condition.

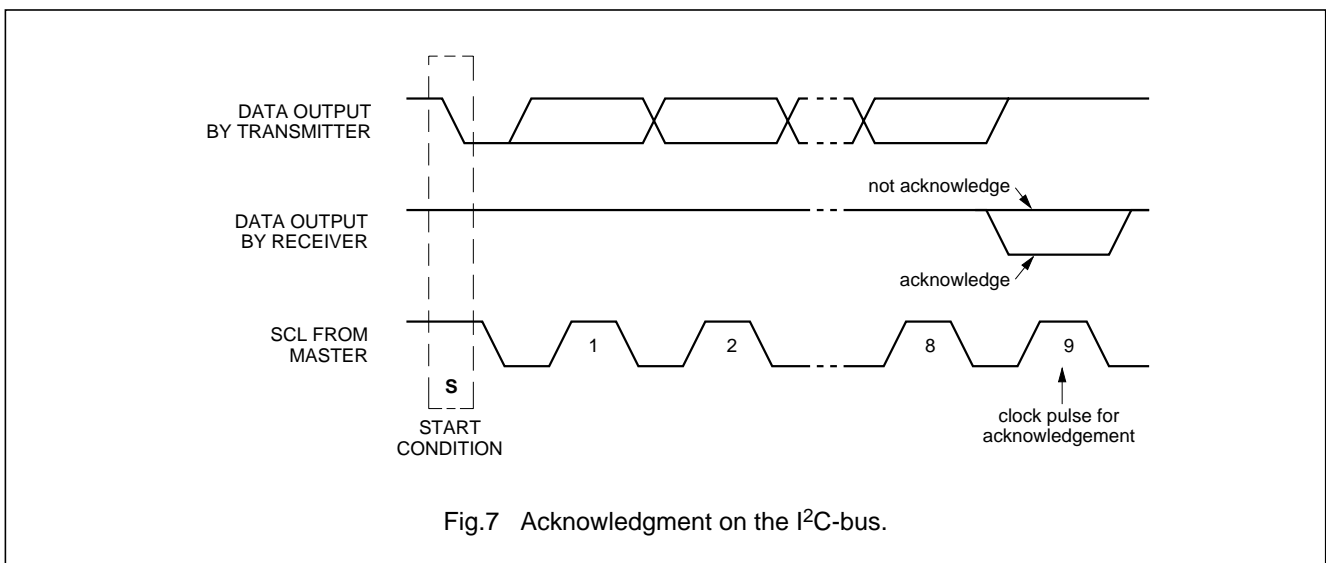

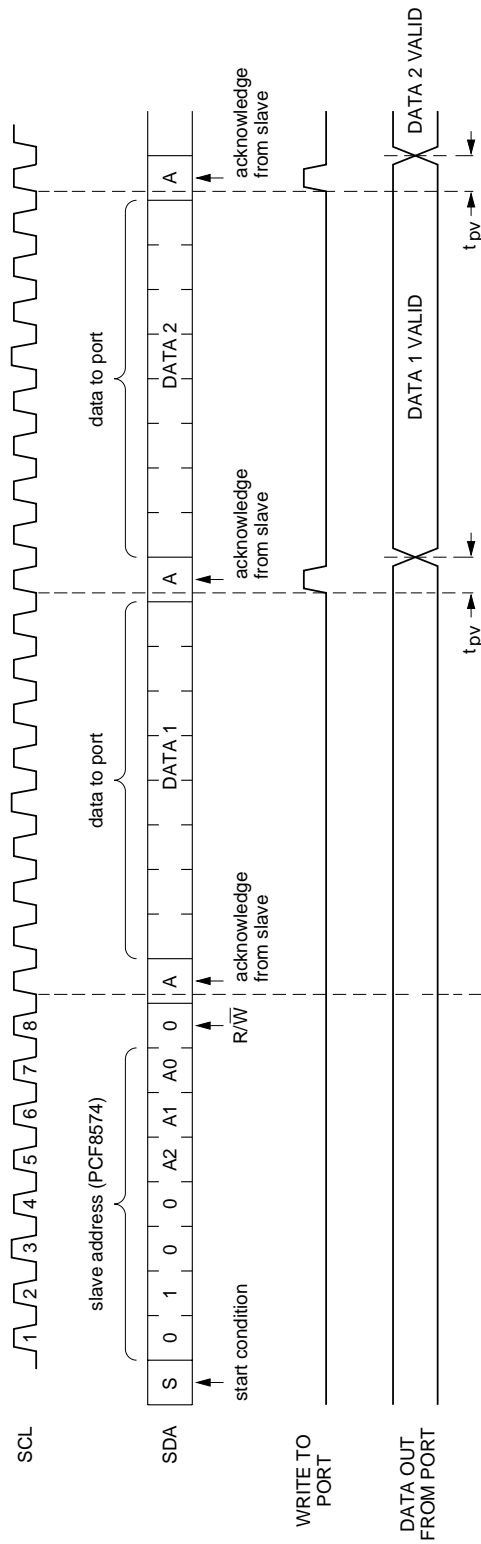
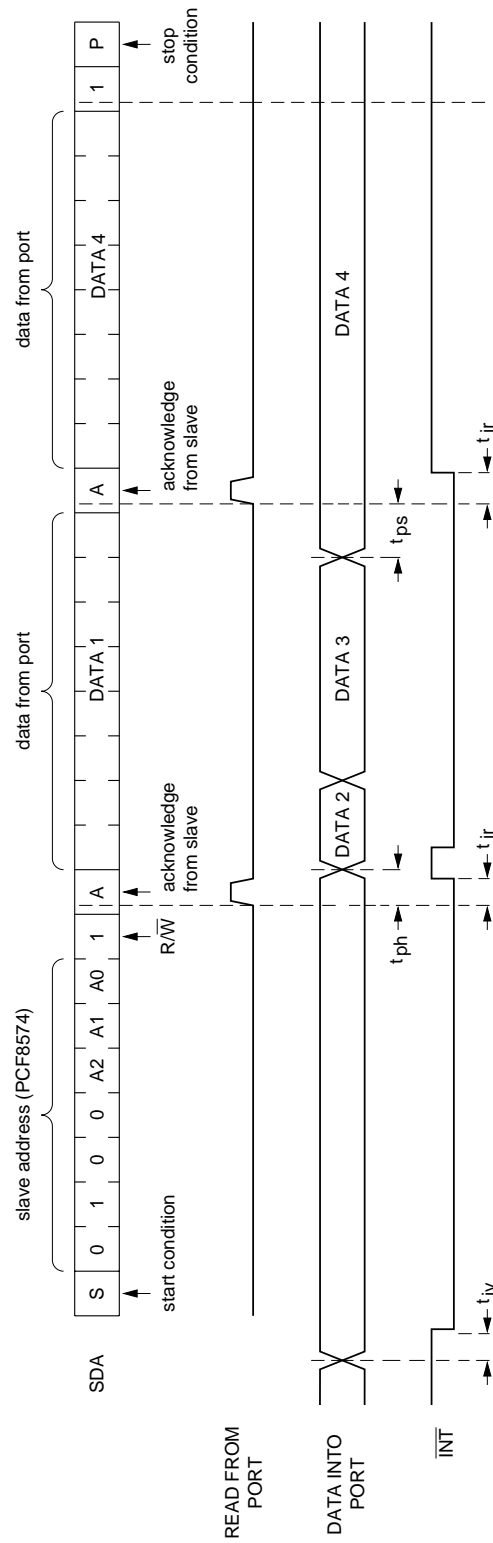

Fig.10 WRITE mode (output).



A LOW-to-HIGH transition of SDA, while SCL is HIGH is defined as the stop condition (P). Transfer of data can be stopped at any moment by a stop condition. When this occurs, data present at the last acknowledge phase is valid (output mode). Input data is lost.

Fig.11 READ mode (input).

Interrupt (see Figs 12 and 13)

The PCF8574 provides an open drain output ($\overline{\text{INT}}$) which can be fed to a corresponding input of the microcontroller. This gives these chips a type of master function which can initiate an action elsewhere in the system.

An interrupt is generated by any rising or falling edge of the port inputs in the input mode. After time t_{iv} the signal $\overline{\text{INT}}$ is valid.

Resetting and reactivating the interrupt circuit is achieved when data on the port is changed to the original setting or data is read from or written to the port which has generated the interrupt.

Resetting occurs as follows:

- In the READ mode at the acknowledge bit after the rising edge of the SCL signal
- In the WRITE mode at the acknowledge bit after the HIGH-to-LOW transition of the SCL signal

- Interrupts which occur during the acknowledge clock pulse may be lost (or very short) due to the resetting of the interrupt during this pulse.

Each change of the I/Os after resetting will be detected and, after the next rising clock edge, will be transmitted as $\overline{\text{INT}}$. Reading from or writing to another device does not affect the interrupt circuit.

Quasi-bidirectional I/Os (see Fig.14)

A quasi-bidirectional I/O can be used as an input or output without the use of a control signal for data direction. At power-on the I/Os are HIGH. In this mode only a current source to V_{DD} is active. An additional strong pull-up to V_{DD} allows fast rising edges into heavily loaded outputs. These devices turn on when an output is written HIGH, and are switched off by the negative edge of SCL. The I/Os should be HIGH before being used as inputs.

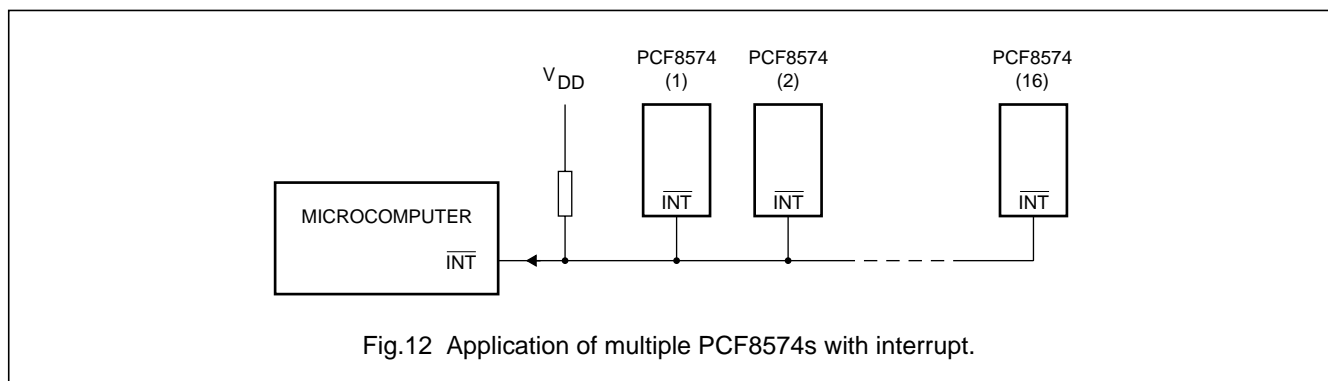

Fig.12 Application of multiple PCF8574s with interrupt.

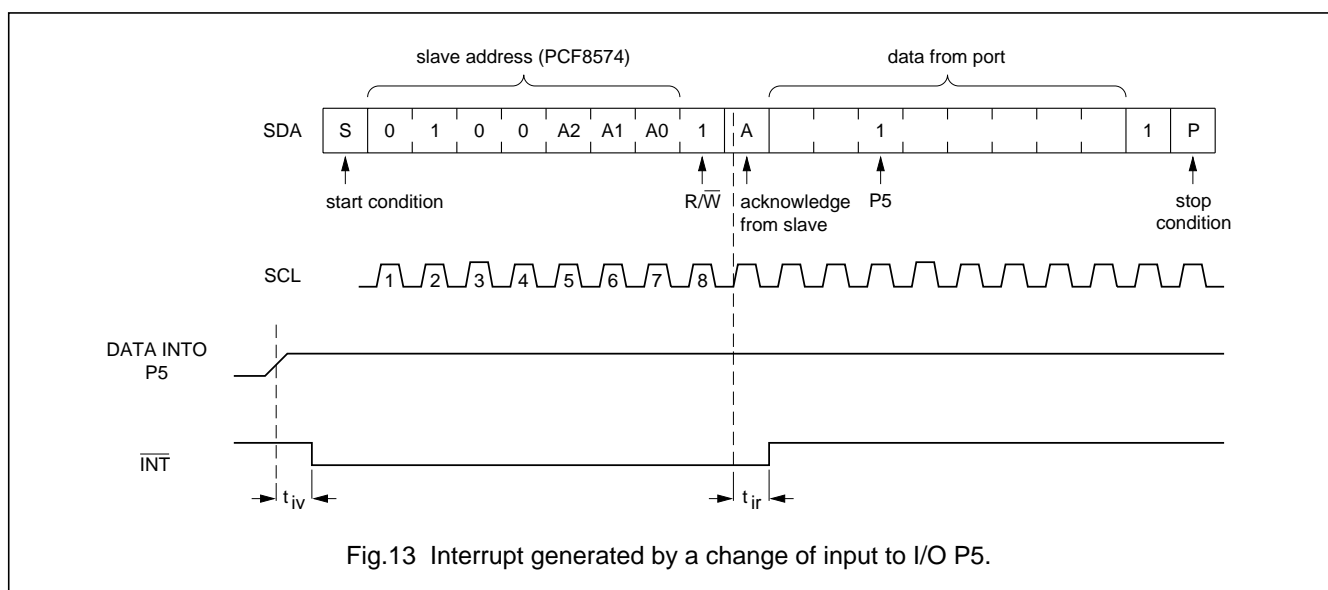

Fig.13 Interrupt generated by a change of input to I/O P5.

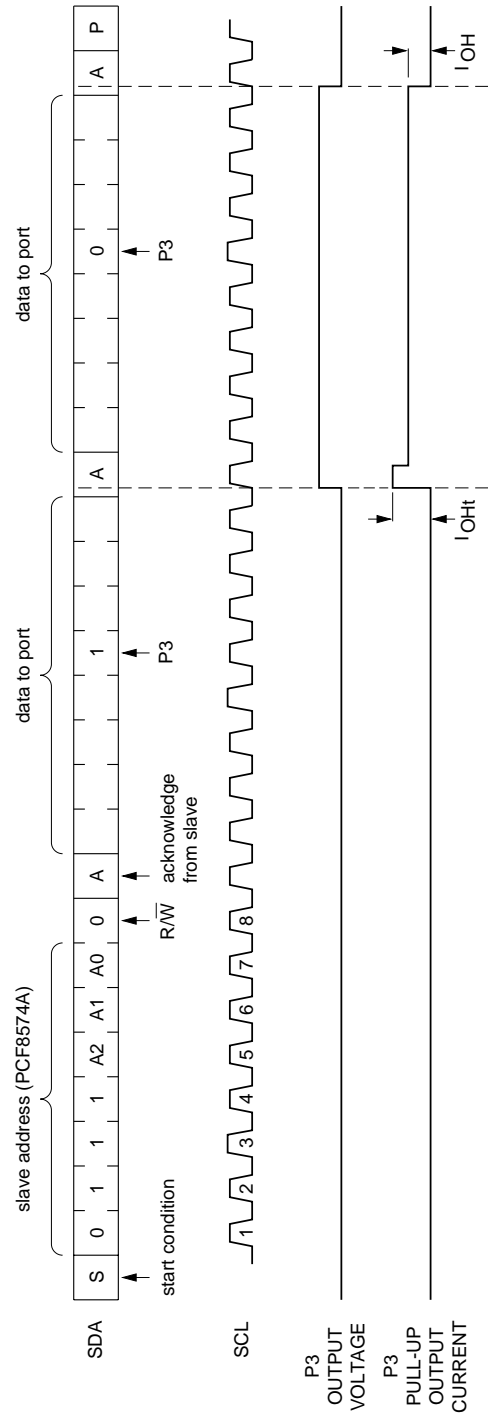

Fig.14 Transient pull-up current I_{OHt} while P3 changes from LOW-to-HIGH and back to LOW.

LIMITING VALUES

In accordance with the Absolute Maximum Rating System (IEC 134).

SYMBOL	PARAMETER	MIN.	MAX.	UNIT
V _{DD}	supply voltage	-0.5	+7.0	V
V _I	input voltage	V _{SS} - 0.5	V _{DD} + 0.5	V
I _I	DC input current	-	±20	mA
I _O	DC output current	-	±25	mA
I _{DD}	supply current	-	±100	mA
I _{SS}	supply current	-	±100	mA
P _{tot}	total power dissipation	-	400	mW
P _O	power dissipation per output	-	100	mW
T _{stg}	storage temperature	-65	+150	°C
T _{amb}	operating ambient temperature	-40	+85	°C

HANDLING

Inputs and outputs are protected against electrostatic discharge in normal handling. However, to be totally safe, it is desirable to take precautions appropriate to handling MOS devices. Advice can be found in Data Handbook IC12 under "Handling MOS Devices".

DC CHARACTERISTICS

 V_{DD} = 2.5 to 6 V; V_{SS} = 0 V; T_{amb} = -40 to +85 °C; unless otherwise specified.

SYMBOL	PARAMETER	CONDITIONS	MIN.	TYP.	MAX.	UNIT
Supply						
V _{DD}	supply voltage		2.5	-	6.0	V
I _{DD}	supply current	operating mode; V _{DD} = 6 V; no load; V _I = V _{DD} or V _{SS} ; f _{SCL} = 100 kHz	-	40	100	μA
I _{stb}	standby current	standby mode; V _{DD} = 6 V; no load; V _I = V _{DD} or V _{SS}	-	2.5	10	μA
V _{POR}	Power-on reset voltage	V _{DD} = 6 V; no load; V _I = V _{DD} or V _{SS} ; note 1	-	1.3	2.4	V
Input SCL; input/output SDA						
V _{IL}	LOW level input voltage		-0.5	-	+0.3V _{DD}	V
V _{IH}	HIGH level input voltage		0.7V _{DD}	-	V _{DD} + 0.5	V
I _{OL}	LOW level output current	V _{OL} = 0.4 V	3	-	-	mA
I _L	leakage current	V _I = V _{DD} or V _{SS}	-1	-	+1	μA
C _i	input capacitance	V _I = V _{SS}	-	-	7	pF

SYMBOL	PARAMETER	CONDITIONS	MIN.	TYP.	MAX.	UNIT
I/Os						
V_{IL}	LOW level input voltage		-0.5	-	+0.3 V_{DD}	V
V_{IH}	HIGH level input voltage		0.7 V_{DD}	-	$V_{DD} + 0.5$	V
$I_{IHL(max)}$	maximum allowed input current through protection diode	$V_I \geq V_{DD}$ or $V_I \leq V_{SS}$	-	-	±400	μA
I_{OL}	LOW level output current	$V_{OL} = 1\text{ V}$; $V_{DD} = 5\text{ V}$	10	25	-	mA
I_{OH}	HIGH level output current	$V_{OH} = V_{SS}$	30	-	300	μA
I_{Oht}	transient pull-up current	HIGH during acknowledge (see Fig.14); $V_{OH} = V_{SS}$; $V_{DD} = 2.5\text{ V}$	-	-1	-	mA
C_i	input capacitance		-	-	10	pF
C_o	output capacitance		-	-	10	pF
Port timing; $C_L \leq 100\text{ pF}$ (see Figs 10 and 11)						
t_{pv}	output data valid		-	-	4	μs
t_{su}	input data set-up time		0	-	-	μs
t_h	input data hold time		4	-	-	μs
Interrupt \overline{INT} (see Fig.13)						
I_{OL}	LOW level output current	$V_{OL} = 0.4\text{ V}$	1.6	-	-	mA
I_L	leakage current	$V_I = V_{DD}$ or V_{SS}	-1	-	+1	μA
TIMING; $C_L \leq 100\text{ pF}$						
t_{iv}	input data valid time		-	-	4	μs
t_{ir}	reset delay time		-	-	4	μs
Select inputs A0 to A2						
V_{IL}	LOW level input voltage		-0.5	-	+0.3 V_{DD}	V
V_{IH}	HIGH level input voltage		0.7 V_{DD}	-	$V_{DD} + 0.5$	V
I_{LI}	input leakage current	pin at V_{DD} or V_{SS}	-250	-	+250	nA

Note

1. The Power-on reset circuit resets the I²C-bus logic with $V_{DD} < V_{POR}$ and sets all I/Os to logic 1 (with current source to V_{DD}).

I²C-BUS TIMING CHARACTERISTICS

SYMBOL	PARAMETER	MIN.	TYP.	MAX.	UNIT
I ² C-BUS TIMING (see Fig.15; note 1)					
f _{SCL}	SCL clock frequency	–	–	100	kHz
t _{SW}	tolerable spike width on bus	–	–	100	ns
t _{BUF}	bus free time	4.7	–	–	μs
t _{SU;STA}	START condition set-up time	4.7	–	–	μs
t _{HD;STA}	START condition hold time	4.0	–	–	μs
t _{LOW}	SCL LOW time	4.7	–	–	μs
t _{HIGH}	SCL HIGH time	4.0	–	–	μs
t _r	SCL and SDA rise time	–	–	1.0	μs
t _f	SCL and SDA fall time	–	–	0.3	μs
t _{SU;DAT}	data set-up time	250	–	–	ns
t _{HD;DAT}	data hold time	0	–	–	ns
t _{VD;DAT}	SCL LOW to data out valid	–	–	3.4	μs
t _{SU;STO}	STOP condition set-up time	4.0	–	–	μs

Note

1. All the timing values are valid within the operating supply voltage and ambient temperature range and refer to V_{IL} and V_{IH} with an input voltage swing of V_{SS} to V_{DD}.

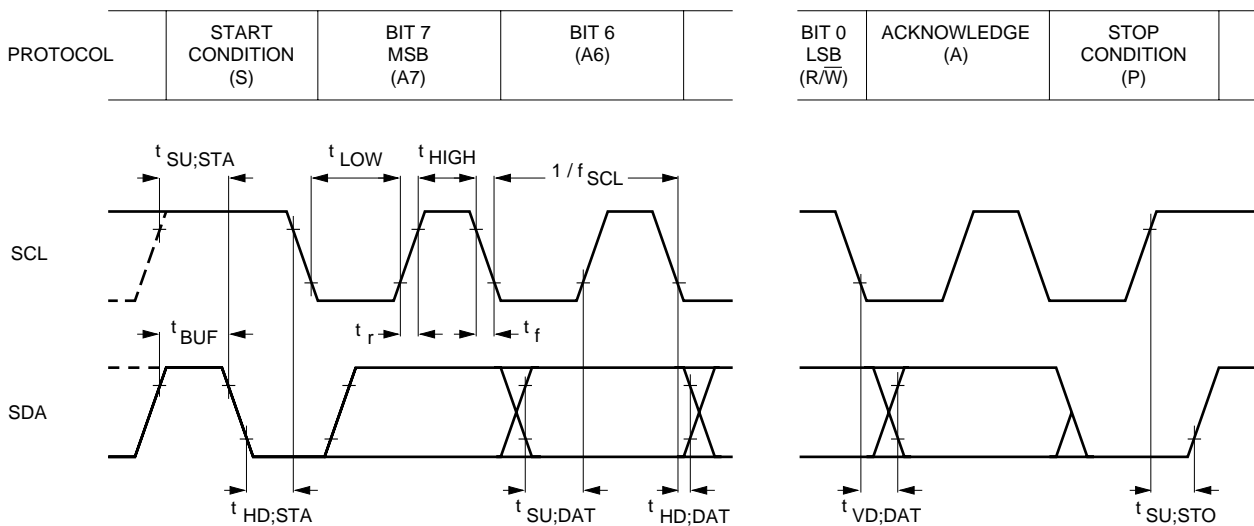
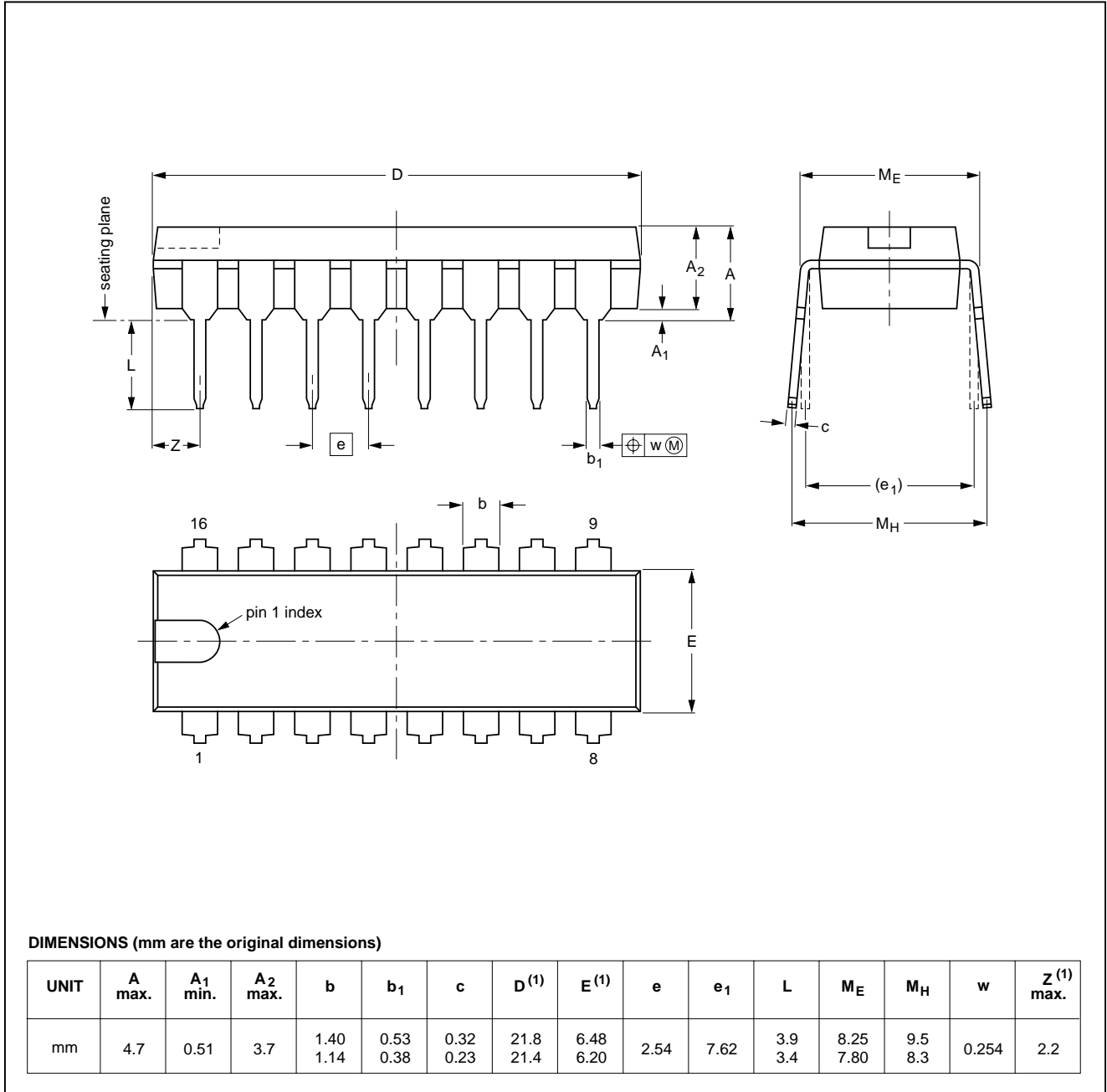

Fig.15 I²C-bus timing diagram.

PACKAGE OUTLINES

DIP16: plastic dual in-line package; 16 leads (300 mil); long body



SOP16W: plastic small outline package; 16 leads; body width 7.5 mm

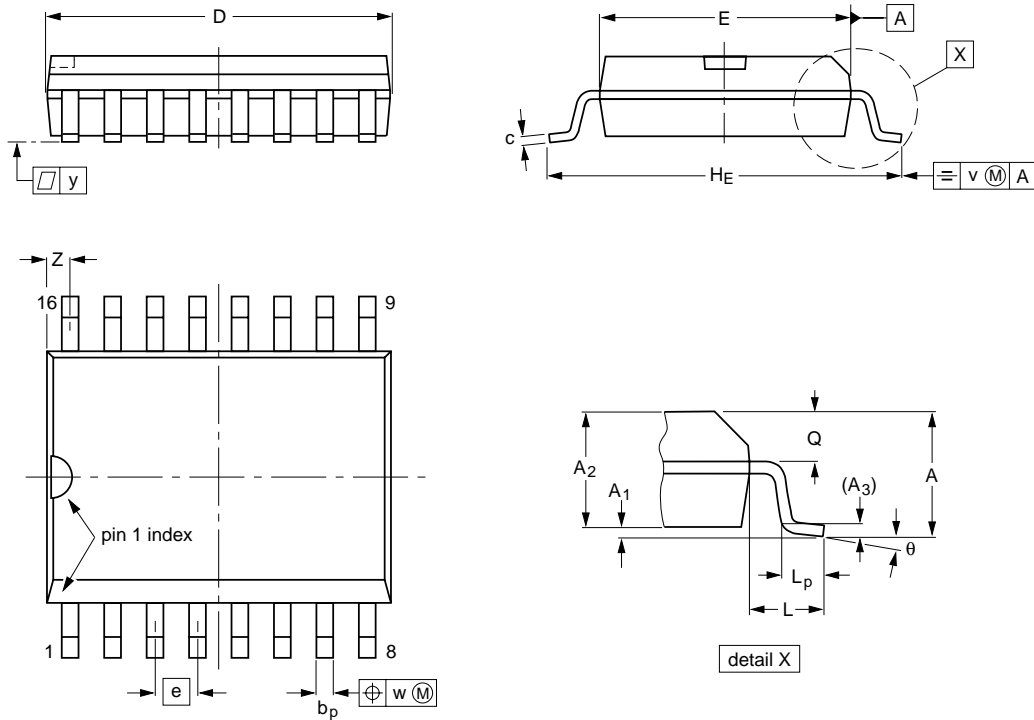

DIMENSIONS (mm are the original dimensions)

UNIT	A max.	A ₁	A ₂	A ₃	b _p	c	D ⁽¹⁾	E ⁽¹⁾	e	H _E	L	L _p	Q	v	w	y	Z ⁽¹⁾	θ
mm	2.65	0.30 0.10	2.45 2.25	0.25	0.49 0.36	0.32 0.23	10.5 10.1	7.6 7.4	1.27	10.65 10.00	1.4	1.1 0.4	1.1 1.0	0.25	0.25	0.1	0.9 0.4	8° 0°

SOP16L: plastic small outline package; 16 leads; body width 3.9 mm

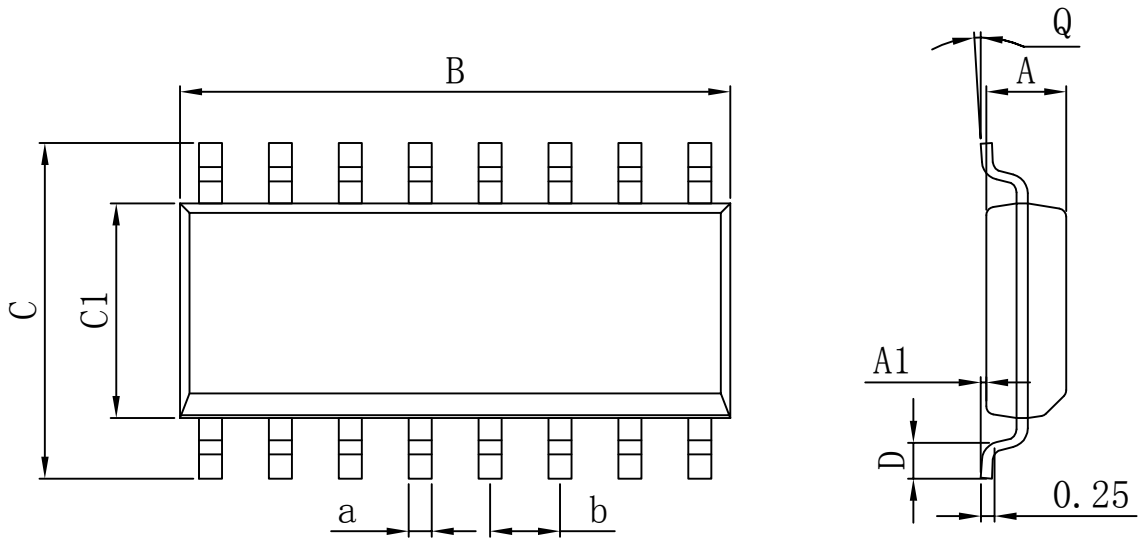

DIMENSIONS (mm are the original dimensions)

Symbol:	A	A1	B	C	C1	D	Q	a	b
Min:	1.35	0.05	9.80	5.80	3.80	0.40	0	0.35	1.27 BSC
Max:	1.55	0.20	10.0	6.20	4.00	0.80	8	0.45	

SSOP20: plastic shrink small outline package; 20 leads; body width 4.4 mm

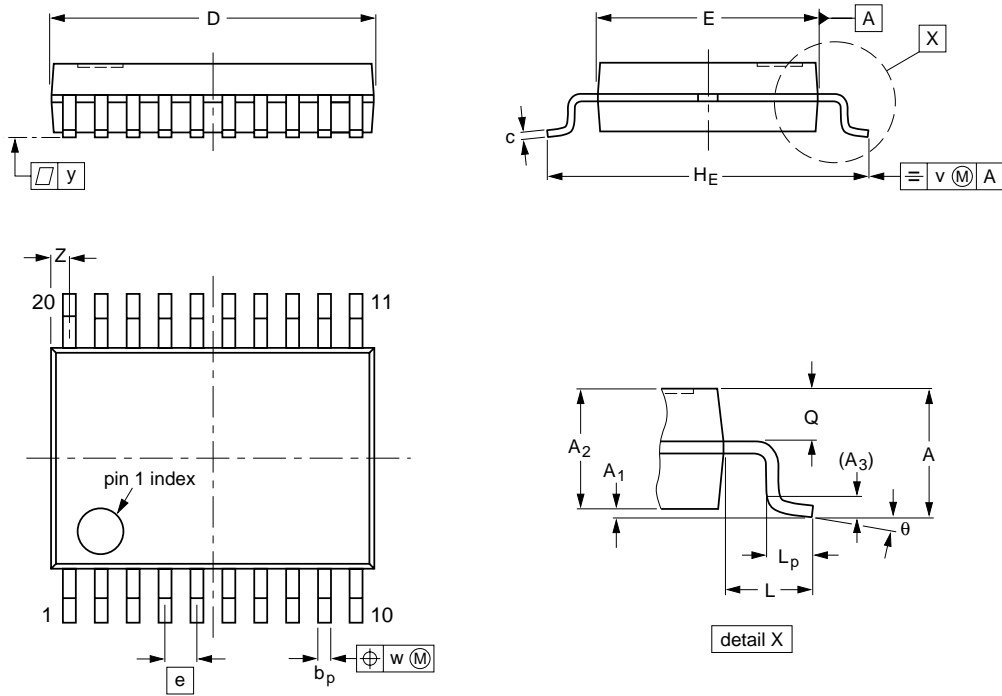

DIMENSIONS (mm are the original dimensions)

UNIT	A _{max.}	A ₁	A ₂	A ₃	b _p	c	D ⁽¹⁾	E ⁽¹⁾	e	H _E	L	L _p	Q	v	w	y	Z ⁽¹⁾	θ
mm	1.5	0.15 0	1.4 1.2	0.25	0.32 0.20	0.20 0.13	6.6 6.4	4.5 4.3	0.65	6.6 6.2	1.0	0.75 0.45	0.65 0.45	0.2	0.13	0.1	0.48 0.18	10° 0°

Important statement:

Huaguan Semiconductor Co,Ltd. reserves the right to change the products and services provided without notice. Customers should obtain the latest relevant information before ordering, and verify the timeliness and accuracy of this information.

Customers are responsible for complying with safety standards and taking safety measures when using our products for system design and machine manufacturing to avoid potential risks that may result in personal injury or property damage.

Our products are not licensed for applications in life support, military, aerospace, etc., so we do not bear the consequences of the application of these products in these fields.

Huaguan Semiconductor Co,Ltd. the performance of the semiconductor products produced by the company can reach the performance indicators that can be applied at the time of sales. the use of testing and other quality control technologies is limited to the quality assurance scope of Huaguan semiconductor. Not all parameters of each device need to be tested. The above documents are for reference only, and all are subject to the physical parameters.

Our documentation is only permitted to be copied without any tampering with the content, so we do not accept any responsibility or liability for the altered documents.

X-ON Electronics

Largest Supplier of Electrical and Electronic Components

Click to view similar products for [Interface - I/O Expanders](#) category:

Click to view products by [HGSEMI](#) manufacturer:

Other Similar products are found below :

[LC709006V-TLM-E](#) [NLVPCA9535EDTR2G](#) [TC7SPN334L6X,LF\(S](#) [PM8055B-FEI](#) [PI4IOE5V9555LEX](#) [PI4IOE5V6534Q2ZLWEX](#)
[PI4IOE5V6416Q2LEX](#) [41700-100](#) [HT8574ARSZ](#) [XL9535QF24](#) [PCF8574AT/TR](#) [HT8574ANZ](#) [MCP23S18T-E/MJ](#) [PCA9539AHF,128](#)
[PCAL9554BPWJ](#) [MCP25050-E/P](#) [MCP23017T-E/ML](#) [PCF8575DB](#) [PCA9554PW.112](#) [PCF8575TS/1.112](#) [MIC74YQS](#) [TCA1116RTWR](#)
[PI4IOE5V9535LEX](#) [PCA9671BS,118](#) [PI4IOE5V9539ZDEX](#) [XRA1201PIG24TR-F](#) [TCA9535MRGER](#) [MCP23018T-E/MJ](#)
[XRA1203IG24TR-F](#) [XRA1201IL24TR-F](#) [PI4IOE5V9535ZDEX](#) [PI4IOE5V96248ZLEX](#) [PI4IOE5V96224ZLEX](#) [MCP23S09T-E/SO](#)
[SC16IS740IPW.112](#) [EM4095HM5016A](#) [HTRC11001T/02EE](#) [PCAL6408AHKX](#) [PCAL6416AEVJ](#) [PCAL9535AHF,128](#) [MCP23018T-E/SS](#)
[CLCS82C55AZ](#) [CY8C9520A-24PVXIT](#) [CY8C9520A-24PVXI](#) [CY8C9540A-24PVXI](#) [20-101-1187](#) [20-668-0030](#) [PI4IOE5V6416ZDEX](#)
[PCF8574P](#) [XD8574AP](#)